

A. Pourmovahed¹
 Power Systems Research Department,
 General Motors Research Laboratories,
 Warren, MI 48090

N. H. Beachley

F. J. Fronczak
 Mechanical Engineering Department,
 University of Wisconsin-Madison,
 Madison, WI 53706

Modeling of a Hydraulic Energy Regeneration System—Part II: Experimental Program

This study reports experimental data taken with a hydraulic energy regeneration system and compares the measured data with analytical results. The system tested consisted of two foam-filled hydraulic accumulators, a variable-displacement piston-type pump/motor, a reservoir and a flywheel. During a series of experiments, energy was repeatedly transferred between the hydraulic accumulators and the flywheel through the pump/motor. Computed system variables compared favorably with the experimental results. At high and moderate pump/motor swivel angles, the round-trip efficiency varied from 61 to 89 percent. It was significantly lower at small angles.

Experimental Program

This section presents the results of regenerative cycling tests at the University of Wisconsin-Madison in which energy was transferred between two hydraulic accumulators and a flywheel. A Rexroth variable-displacement pump/motor in combination with two foam-filled Parker piston-type accumulators were used in the tests. During the cycling of the energy between the accumulators and a flywheel, a data acquisition computer recorded seven parameters: the pump/motor displacement, the piston position in one of the accumulators, the inlet oil pressure of the pump, both accumulator gas pressures, the torque between the pump/motor and flywheel, and the flywheel speed. Tests were run with different pump/motor displacements and with two different oil temperatures.

A Apparatus. The circuit used for these tests is shown in Fig. 1. Power for the initial accumulator charge was provided by a 50 hp hydraulic power supply. The power supply relief valve was set to about 21.4 MPa (3100 psi) to set the maximum pressure in the accumulators when they were being charged. Ball valve No. 1 and an orifice isolated the power supply from the rest of the circuit. The two, 8.185-liter (2.162-gallon) piston-type Parker accumulators were both model No. A6R0462B69E and are rated at 20.7 MPa (3000 psi). More information on these accumulators is given by Baum (1987). The rest of the circuit consisted of two ball valves and a 38-liter (10-gallon) accumulator used as a pressurized reservoir.

The accumulators were both filled with elastomeric foam during all of the tests. One accumulator contained 762 grams (1.68 lb) of foam and the other contained 734 grams (1.62 lb).

B Instrumentation. Instrumentation included three pressure transducers, two linear variable differential transformers

(LVDT's), one torquemeter, and one digital encoder. The pressure transducers were manufactured by Schaevitz, type P2503-0001, and are rated at 0–41.4 MPa (0 to 6000 psig). Their outputs were amplified by Himmelstein transducer amplifiers

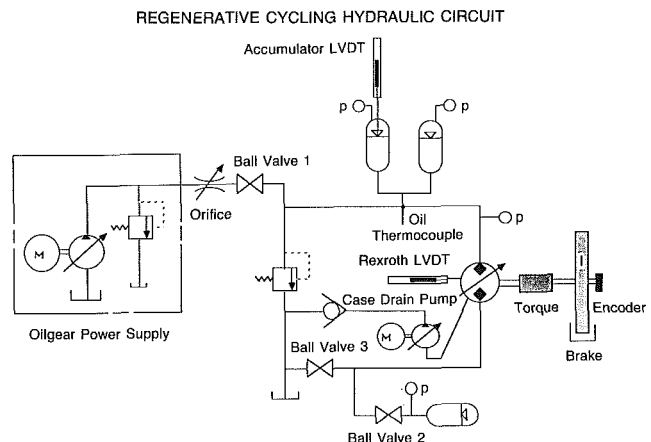

Fig. 1 The regenerative cycling hydraulic circuit

Table 1 Test conditions

Test number	Precharge pressure MPa, abs	Pump/motor angle (degrees)	Starting reservoir pressure kPa, abs	Ending reservoir pressure kPa, abs	Case drain flow (L)
1	6.998	20	308	480	.1802
2	6.998	10	308	467	.3002
3	6.998	3	308	467	.3800
4	6.998	3	308	467	.4202
5	6.998	2	308	384	.3100
6	6.998	5	308	446	.5901
7	6.998	10	308	453	.5201
8	6.998	15	308	460	.3899
9	6.998	20	308	467	.2801

¹Currently, Assistant Professor, Mechanical Engineering Department, GMI Engineering & Management Institute, Flint, MI 48504.

Contributed by the Dynamic Systems and Control Division for publication in the JOURNAL OF DYNAMIC SYSTEMS, MEASUREMENT, AND CONTROL. Manuscript received by the Dynamic Systems and Control Division March 22, 1990; revised manuscript received March 1991. Associate Editor: A. Akers.

Table 2 Flywheel loss coefficients

i	e_i	Unit
0	-0.14615	N•m
1	-2.4161×10^{-4}	N•m/(rpm)
2	-3.9135×10^{-7}	N•m/(rpm) ²
3	8.6054×10^{-11}	N•m/(rpm) ³

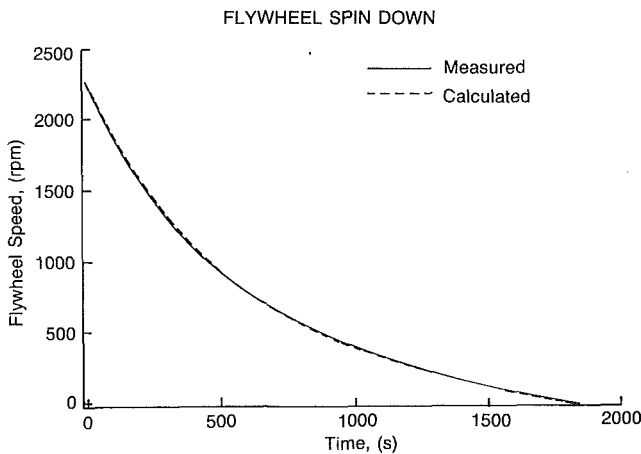
**Fig. 2 Measured and calculated flywheel speed history during the spin-down test****Table 3 Loss coefficient estimates for Rexroth A2V pump/motor size: 107 cm³/rev**

Date source	C_v	C_f	C_h	$10^9 C_s$	$10^5 C_{st}$
Manufacturer	23,523	.0537	53.56	4.259	0
UW-Madison	153,407	.0048	0	1.042	1.20
Combined	92,622	.0216	20.54	1.123	2.00

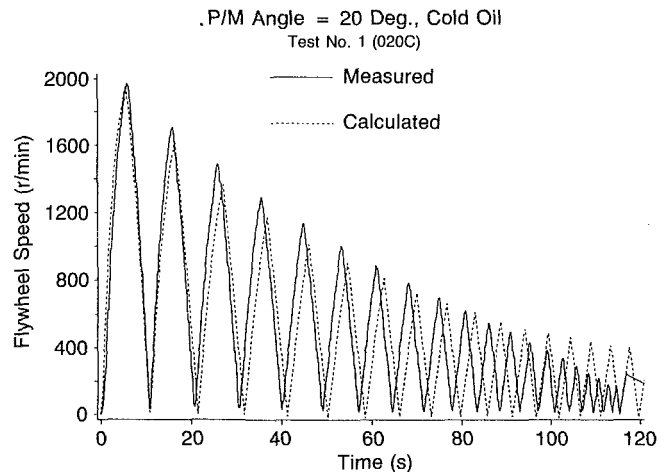
**Fig. 3 Flywheel speed history for Test number 1**

model 6-201, which have an output of ± 5 volts. These pressure transducers were calibrated with a dead-weight tester.

The accumulator piston position was measured with a Schaevitz LVDT model 10000HR with a range of ± 10 inches and 0.24% linearity. A 6.35-mm (1/4-in.) diameter rod connected the accumulator piston to the LVDT core. The pump/motor displacement was measured using a Schaevitz LVDT model 2000HR with a range of ± 5.08 cm (± 2 in.) and 0.15 percent linearity. A 6.35-mm (1/4-in.) diameter rod connected the pump/motor to the LVDT core. The LVDT output signals were conditioned using Himmelstein LVDT amplifier models 6-203A, which have an output of ± 5 volts. The LVDT's were calibrated using a vernier caliper.

The torque was measured using a Himmelstein MCRT torque meter model 9-02T with a range of 452 N•m (4000 in•lb) and 0.1 percent linearity. The torque meter output signal was conditioned by a Himmelstein transducer amplifier model 6-201, which has an output of ± 5 volts.

The flywheel speed was measured using a Hewlett Packard optical encoder model HEDS-6000. An encoder interface converted the signal from the encoder to a binary code which was read by the computer.

The seven signals were continuously sampled during each test using an ISAAC 41, a 12-bit A-D and binary data acquisition system manufactured by Cyborg Corporation, and an IBM computer, model PC. A second IBM PC computer with a Data Translation Corporation data acquisition and control card was used to control the displacement of the Rexroth pump/motor.

C Procedure. For each test, the following procedure was followed: Ball valves Nos. 1, 2, and 3 were opened and oil was circulated through the system until it was at the desired test temperature. Ball valve No. 3 was then closed and oil allowed to flow into the low pressure reservoir. The reservoir was charged with oil until the pressure was 308 kPa, abs (30 psig), the amount of boost pressure required by the Rexroth pump/motor when running as a pump. At this point the flywheel was braked to a stop and the two high pressure accumulators were charged to 20.79 MPa, abs (3000 psig). When

the relief valve of the hydraulic power supply started to relieve, the data acquisition was started. Ball valve No. 1 was closed and the brake released. This allowed the flywheel to accelerate while the accumulators were discharging. When the accumulators were nearly discharged, the displacement of the Rexroth pump/motor was changed by going "over center." This turned the unit into a pump so that it could begin charging the accumulators using the energy in the flywheel. When the flywheel stopped spinning, the accumulators started the Rexroth pump/motor turning in the opposite direction, since the stroke of the unit was not changed at this point. The process was then repeated, cycling the energy between the flywheel and the high pressure accumulators until it was dissipated through losses in the system.

Two components shown in Fig. 1 have functions which may not be readily apparent. These are the orifice and ball valve No. 2. The orifice's only function was to allow for a safe discharge of the oil in case of problems during the test. Since the orifice is not part of the regenerative circuit, its inclusion does not affect the efficiency of the system. Ball valve No. 2 is attached directly to the low pressure reservoir and is sometimes closed when the system is configured differently.

The pump/motor displacement, accumulator piston position, pressures, torques, and speeds measured during the tests were stored on floppy disks. Table 1 shows the conditions for all nine tests.

The reservoir used in this investigation was a 38-liter (10-gallon) hydraulic accumulator. Due to its large volume, the gas pressure variation was small. For example, in test No. 1, the reservoir pressure varied from 308 to 480 kPa, abs (30 to 55 psig). A constant reservoir pressure (the average value) can, therefore, be assumed.

D Flywheel Spin Tests. As a prelude to the regenerative cycling tests the flywheel losses were determined so that their effect could be taken into account when analyzing the regenerative cycling data.

The hardware was configured slightly differently for this test than for the regenerative cycling tests. The major change was that the power to the flywheel was provided by a Vickers

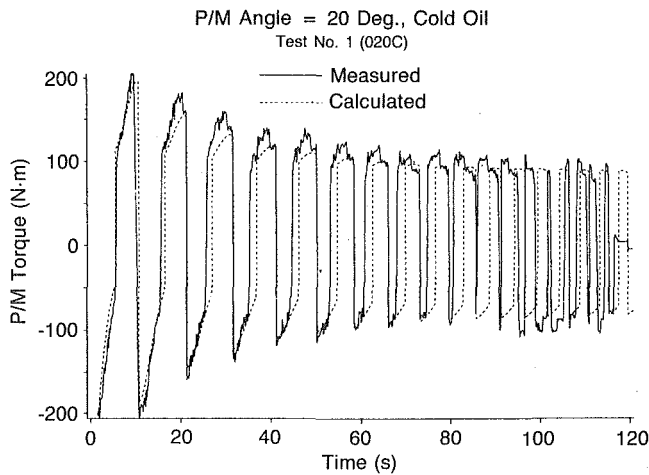

Fig. 4 Pump/motor torque history for Test number 1

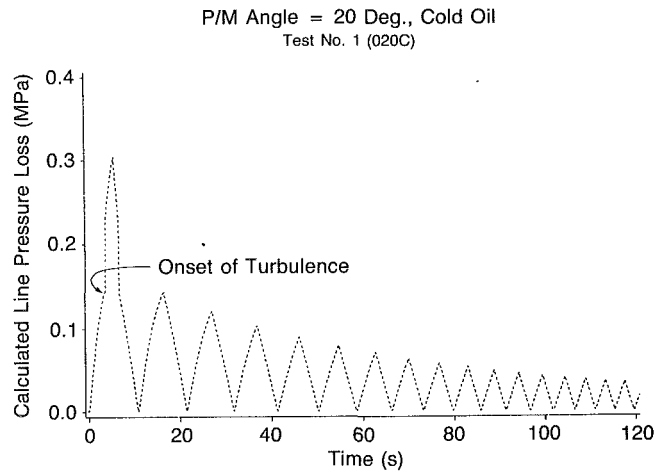

Fig. 7 Calculated line pressure loss history for Test number 1

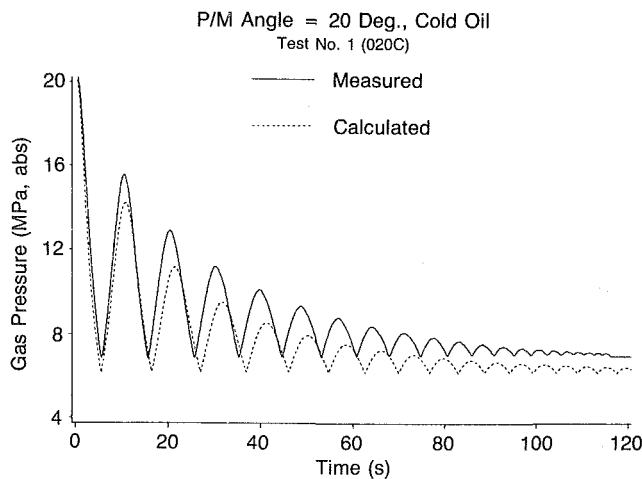

Fig. 5 Accumulator gas pressure history for Test number 1

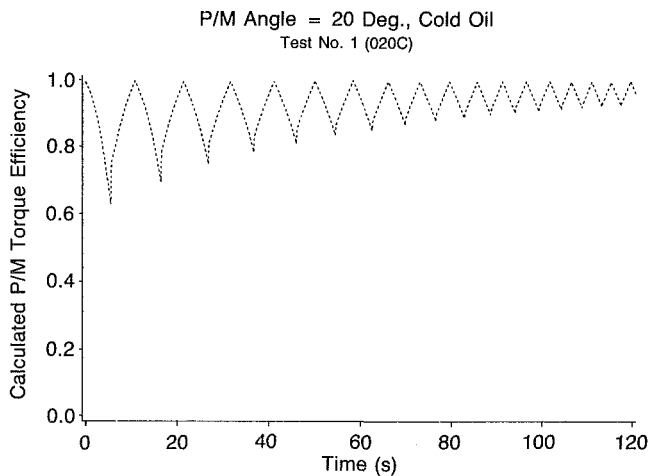

Fig. 8 Calculated pump/motor torque efficiency history for Test number 1

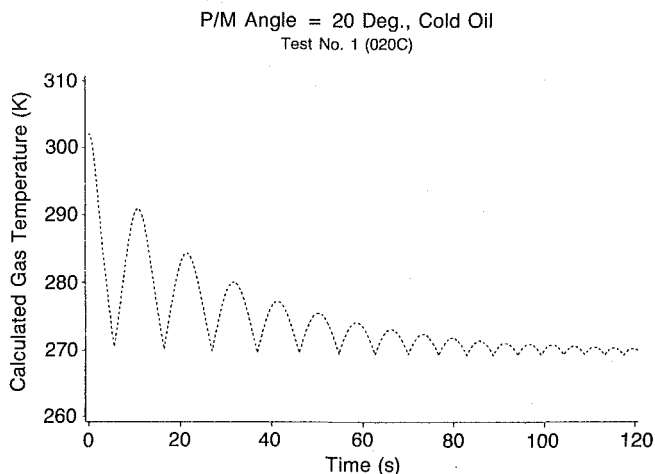

Fig. 6 Calculated accumulator gas temperature history for Test number 1

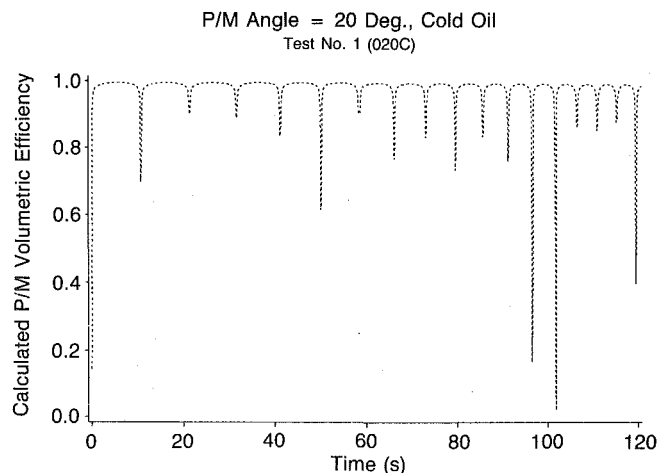

Fig. 9 Calculated pump/motor volumetric efficiency history for Test number 1

hydraulic motor rather than the Rexroth pump/motor. This change was done to allow the motor to be quickly disengaged from the flywheel. In order to facilitate the disengagement, the Vickers motor was mounted so that it could slide back and forth. The motor was coupled to the flywheel and the tor-

quemeter by means of a face plate mounted to a flexible coupling which engaged two pins mounted on the torquemeter coupling plate. Instrumentation consisted of the IBM PC computer, ISAAC 41, HEDS-6000 optical encoder, and interface.

The test was conducted as follows. The motor was slid into position to engage the pins on the torquemeter coupling plate. The motor was used to accelerate the flywheel to 2250 RPM

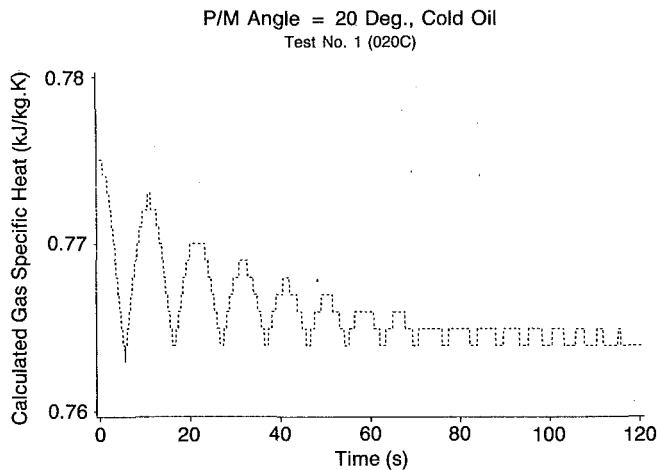

Fig. 10 Calculated gas specific heat (c_v) history for Test number 1

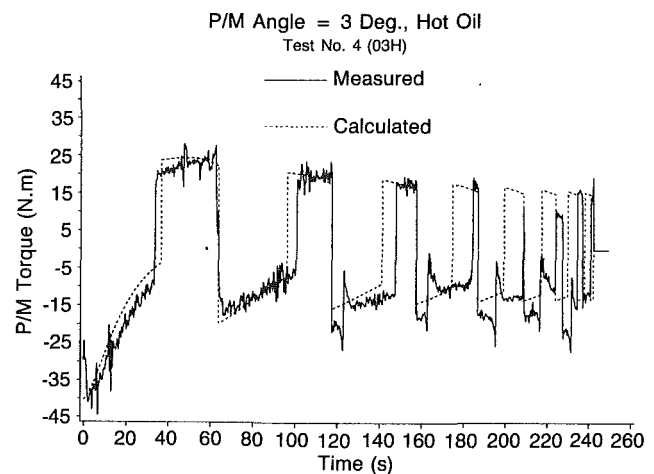

Fig. 12 Pump/motor torque history for Test number 4

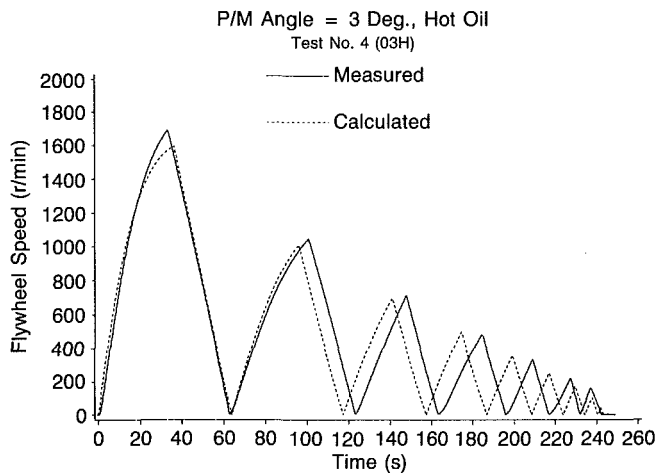

Fig. 11 Flywheel speed history for Test number 4

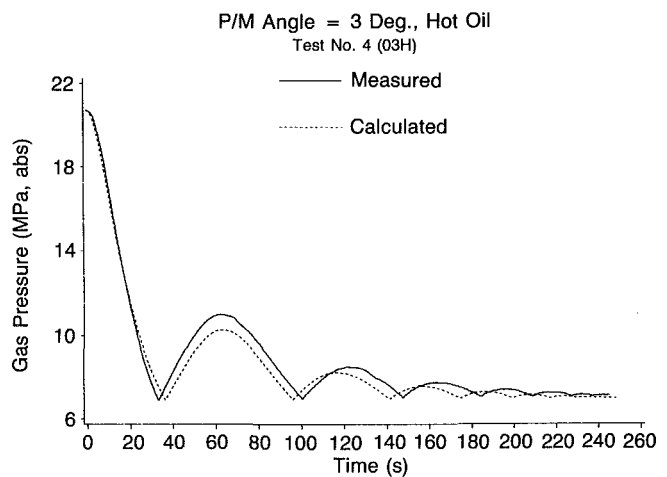

Fig. 13 Accumulator gas pressure history for Test number 4

at which time the motor was slid back to disengage it from the flywheel and the torquemeter. At this time the data acquisition began. The speed of the flywheel was sampled at a rate of 1 Hz until the flywheel stopped. Three identical tests were run to ascertain repeatability.

The experimental spin-loss data obtained for the flywheel used in this study resulted in the numerical values shown in Table 2 (see Eq. (27), Part I).

To test the accuracy of Eq. (27) in predicting the flywheel spin loss, this equation was integrated to calculate the flywheel speed history during the spin-down test. Figure 2 shows the calculated and the measured flywheel speed indicating excellent agreement, thus validating the regression results.

Estimation of the Pump/Motor Loss Coefficients. A nonlinear least-squares method can be used to estimate the loss coefficients in Eqs. (16_p) and (21_p) for a pump/motor (see Part I). For the unit used in this investigation data were available from two sources: the manufacturer (Rexroth) and the University of Wisconsin (Baum, 1987). Separate estimates for each data source as well as combined estimates based on all the data were obtained. The results are given in Table 3.

Examination of the estimated loss coefficients reveals a significant difference between the data from the two sources. Since the two sets of data give different results, it is difficult to know which data to use or whether either source of data can provide adequate information.

Comparison of Experimental and Analytical Results

Figure 3 shows the experimental and the analytical flywheel speed history for Test number 1.² It is seen that there is good agreement between the two curves during the first few cycles, but as time goes on the accumulation of errors causes a noticeable difference and phase shift between the experimental and the analytical results. These differences can almost entirely be attributed to the uncertainties in the pump/motor efficiency data. Similar comments apply to the pump/motor torque (Fig. 4) and the accumulator gas pressure history (Fig. 5).

Accumulator gas expansion in the first cycle resulted in a calculated drop of 31.5K in the gas temperature (Fig. 6). This drop is relatively small because during this expansion process a substantial amount of heat transferred from the foam to the gas.

Figure 7 shows the calculated total pressure drop in all connecting lines between the accumulators and the reservoir. Transition from laminar to turbulent flow during the first cycle is evident from the sudden rise in the pressure drop.

Figures 8 and 9 show the calculated torque and volumetric efficiencies as functions of time. As the pump/motor speed approaches zero, the leakage terms in Eq. (16) become large. Under these conditions (small S and σ), this equation does not

²In all analytical computations, the two accumulators were treated as a single accumulator twice as large, and with the same total foam mass. The input data are shown in the Appendix.

P/M Angle = 3 Deg., Hot Oil
Test No. 4 (03H)

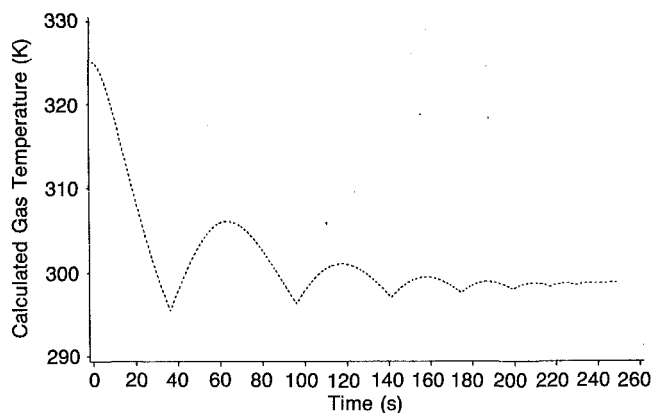

Fig. 14 Calculated accumulator gas temperature history for Test number 4

P/M Angle = 3 Deg., Hot Oil
Test No. 4 (03H)

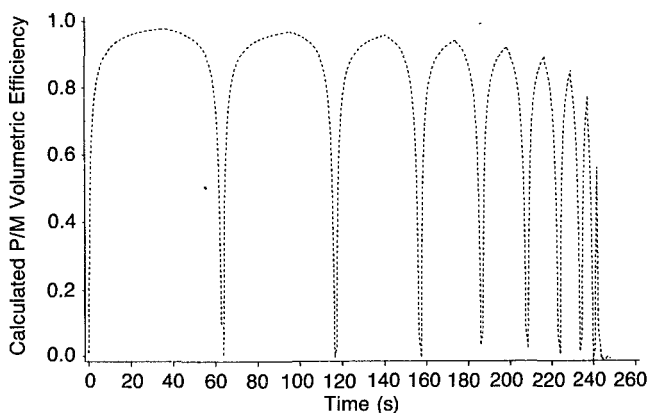

Fig. 17 Calculated pump/motor volumetric efficiency history for Test number 4

P/M Angle = 3 Deg., Hot Oil
Test No. 4 (03H)

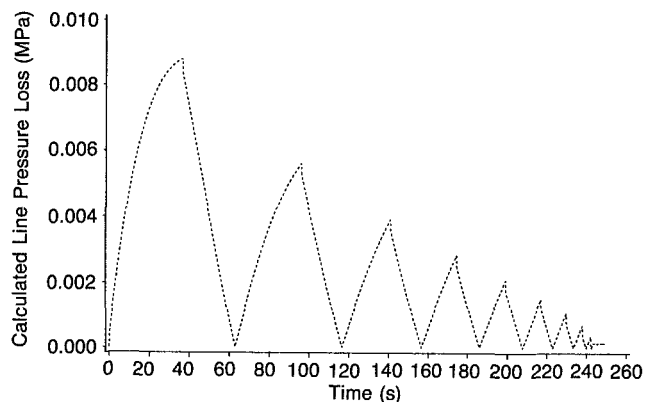

Fig. 15 Calculated line pressure loss history for Test number 4

P/M Angle = 3 Deg., Hot Oil
Test No. 4 (03H)

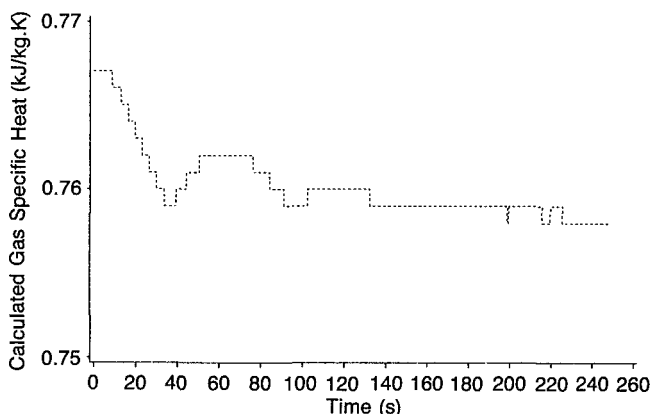

Fig. 18 Calculated gas specific heat (c_p) history for Test number 4

P/M Angle = 3 Deg., Hot Oil
Test No. 4 (03H)

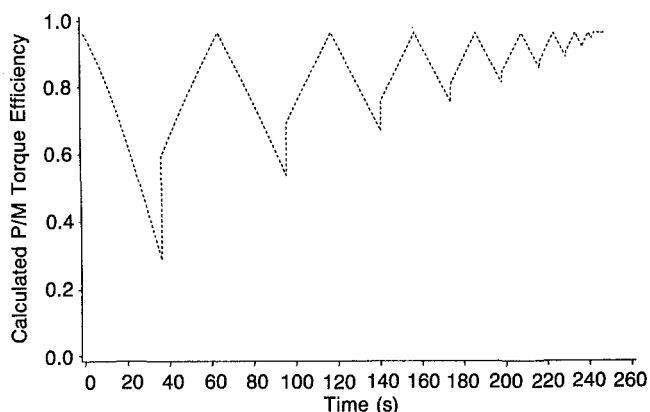

Fig. 16 Calculated pump/motor torque efficiency history for Test number 4

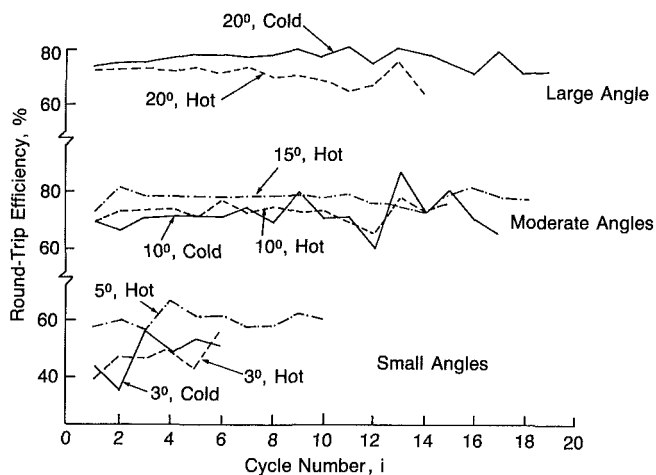

Fig. 19 Round-trip efficiency versus the cycle number for various pump/motor swivel angles and oil temperatures

accurately predict pump volumetric efficiency. Fortunately, this occurs only for a few time steps in every cycle and hardly affects the overall results. The torque efficiency curve does not exhibit such behavior.

The variation in the gas specific heat (c_p) is shown in Fig. 10. Due to the "isothermalization" effect of the foam, the

variation in c_p is less than 2 percent. For a conventional accumulator (without foam), however, the gas specific heat variation may be significant and must be taken into account.

Figures 11 through 18 show similar results for Test number 4 where the swivel angle was small (3 deg) compared to the prior data.

APPENDIX

The Input Data

The following numerical values were used as input data for all test runs:

The Accumulator

Foam Specific Heat: 2.3 kJ/kg·K (Brandrup and Immergut)
 Mass of Gas: 1.213 kg
 Mass of Foam: 1.496 kg
 Maximum Gas Volume: 15.271 L
 Thermal Time Constant: 300 s
 Frictional Loss: 4 percent of Input Energy

The Pump/Motor

Displacement: 107 cm³/rev
 Coefficient of Friction: 0.0048
 Hydrodynamic Loss Coefficient: 0
 Laminar Coefficient of Slip: 1.042×10^{-9}
 Turbulent Coefficient of Slip: 1.20×10^{-5}
 Coefficient of Viscous Drag: 153,407
 Maximum Swivel Angle: 25 degrees

Lines, Fluid, Flywheel

Equivalent Hose Length: 11.96 m
 Hose Internal Diameter: 0.025 m
 Oil Density: 869 kg/m³
 Flywheel Inertia: 3.98 kg·m²
 Initial Flywheel Speed: 1 RPM

The following values were used for Tests 1 and 4:

	Test 1	Test 4
Accumulator Wall Temperature (K)	302	325
Fluid Condition	Cold	Hot
Fluid Kinematic Viscosity (cSt)	60	24
Initial Gas Temperature (K)	302	325
Pump/Motor Swivel Angle (degrees)	± 20	± 3
Reservoir Pressure (MPa, abs)	0.394	0.3875

Round-trip efficiencies were calculated from Eq. (32), Part I, based on the experimentally-measured flywheel speed. Figure 19 shows this efficiency versus the cycle number for eight tests. The round-trip efficiency could not be calculated for Test number 5. For this test, the pump/motor swivel angle was 2 degrees and due to excessive losses in the pump/motor the flywheel accelerated only once.

By examining Fig. 19, one can observe that at high and moderate pump/motor swivel angles, the round-trip efficiency varied from 61 to 89 percent. At small angles, however, this efficiency was as low as 34 percent. Large variations in the round-trip efficiency from one cycle to the next occurred in some tests. This was caused by an abrupt change in the pump/motor angle which happened a few times during the tests.

Conclusions

1. The analytical models developed for all system components are valid.
2. If properly selected, the combined losses of the components used in the hydraulic energy regeneration system are not prohibitive for use in a hydraulic hybrid vehicle.
3. At high pump/motor swivel angles, the flow of hydraulic fluid out of the accumulator can become turbulent.
4. The specific heat of nitrogen gas in a foam-filled hydraulic accumulator may be assumed constant.

References

- Baum, S. A., 1987, "Investigation of a Dual Pump/Motor Hydraulic Accumulator Energy Storage Automobile," MS thesis, Mechanical Engineering Department, University of Wisconsin-Madison.
 Brandrup, J., and Immergut, E. H., *Polymer Handbook*, 2nd Edition, John Wiley & Sons, p. III-215.