

10-41 A steam power plant that operates on a reheat Rankine cycle is considered. The condenser pressure, the net power output, and the thermal efficiency are to be determined.

Assumptions 1 Steady operating conditions exist. 2 Kinetic and potential energy changes are negligible.

Analysis (a) From the steam tables (Tables A-4, A-5, and A-6),

$$\left. \begin{array}{l} P_3 = 12.5 \text{ MPa} \\ T_3 = 550^\circ\text{C} \end{array} \right\} \begin{array}{l} h_3 = 3476.5 \text{ kJ/kg} \\ s_3 = 6.6317 \text{ kJ/kg}\cdot\text{K} \end{array}$$

$$\left. \begin{array}{l} P_4 = 2 \text{ MPa} \\ s_{4s} = s_3 \end{array} \right\} h_{4s} = 2948.1 \text{ kJ/kg}$$

$$\eta_T = \frac{h_3 - h_4}{h_3 - h_{4s}}$$

$$\begin{aligned} \rightarrow h_4 &= h_3 - \eta_T(h_3 - h_{4s}) \\ &= 3476.5 - (0.85)(3476.5 - 2948.1) \\ &= 3027.3 \text{ kJ/kg} \end{aligned}$$

$$\left. \begin{array}{l} P_5 = 2 \text{ MPa} \\ T_5 = 450^\circ\text{C} \end{array} \right\} \begin{array}{l} h_5 = 3358.2 \text{ kJ/kg} \\ s_5 = 7.2815 \text{ kJ/kg}\cdot\text{K} \end{array}$$

$$\left. \begin{array}{l} P_6 = ? \\ x_6 = 0.95 \end{array} \right\} h_6 = \quad (\text{Eq. 1})$$

$$\left. \begin{array}{l} P_6 = ? \\ s_6 = s_5 \end{array} \right\} h_{6s} = \quad (\text{Eq. 2})$$

$$\eta_T = \frac{h_5 - h_6}{h_5 - h_{6s}} \rightarrow h_6 = h_5 - \eta_T(h_5 - h_{6s}) = 3358.2 - (0.85)(3358.2 - h_{6s}) \quad (\text{Eq. 3})$$

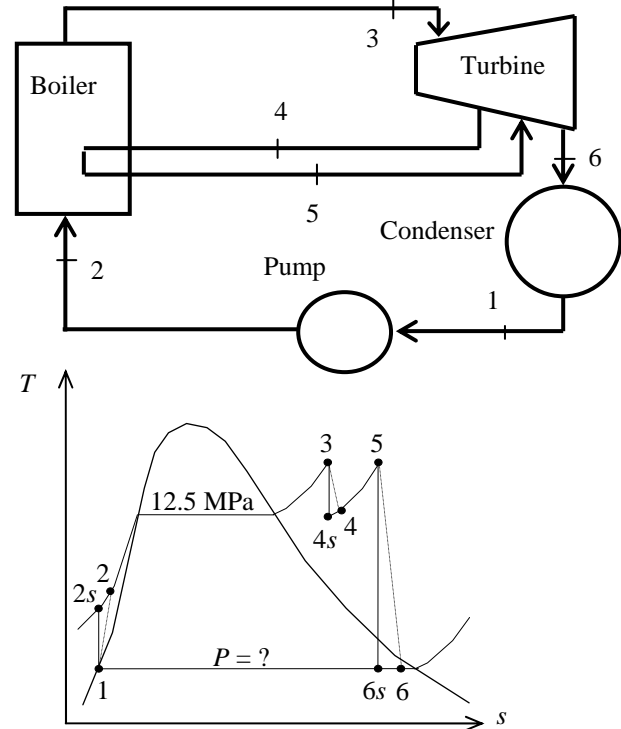

The pressure at state 6 may be determined by a trial-error approach from the steam tables or by using EES from the above three equations:

$$P_6 = \mathbf{9.73 \text{ kPa}}, \quad h_6 = 2463.3 \text{ kJ/kg},$$

(b) Then,

$$h_1 = h_f @ 9.73 \text{ kPa} = 189.57 \text{ kJ/kg}$$

$$v_1 = v_f @ 10 \text{ kPa} = 0.001010 \text{ m}^3/\text{kg}$$

$$\begin{aligned} w_{p,\text{in}} &= v_1(P_2 - P_1)/\eta_p \\ &= (0.00101 \text{ m}^3/\text{kg})(12,500 - 9.73 \text{ kPa}) \left(\frac{1 \text{ kJ}}{1 \text{ kPa}\cdot\text{m}^3} \right) / (0.90) \\ &= 14.02 \text{ kJ/kg} \end{aligned}$$

$$h_2 = h_1 + w_{p,\text{in}} = 189.57 + 14.02 = 203.59 \text{ kJ/kg}$$

Cycle analysis:

$$q_{\text{in}} = (h_3 - h_2) + (h_5 - h_4) = 3476.5 - 203.59 + 3358.2 - 2463.3 = 3603.8 \text{ kJ/kg}$$

$$q_{\text{out}} = h_6 - h_1 = 2463.3 - 189.57 = 2273.7 \text{ kJ/kg}$$

$$\dot{W}_{\text{net}} = \dot{m}(q_{\text{in}} - q_{\text{out}}) = (7.7 \text{ kg/s})(3603.8 - 2273.7) \text{ kJ/kg} = \mathbf{10,242 \text{ kW}}$$

(c) The thermal efficiency is

$$\eta_{\text{th}} = 1 - \frac{q_{\text{out}}}{q_{\text{in}}} = 1 - \frac{2273.7 \text{ kJ/kg}}{3603.8 \text{ kJ/kg}} = 0.369 = \mathbf{36.9\%}$$