

The Mathematics of Perspective Drawing: From Vanishing Points to Projective Geometry

Randall Pyke
March 2019

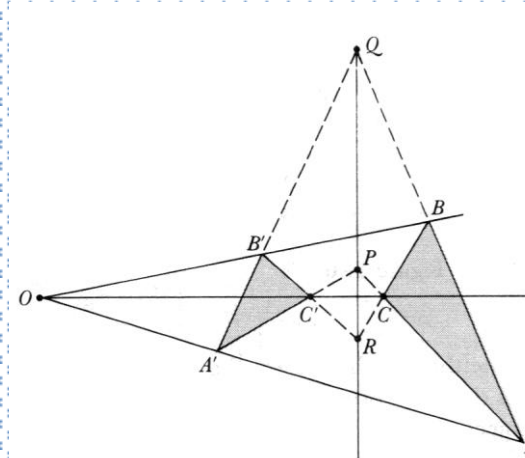

This presentation: www.sfu.ca/~rpyke → presentations → perspective
(www.sfu.ca/~rpyke/perspective.pdf)

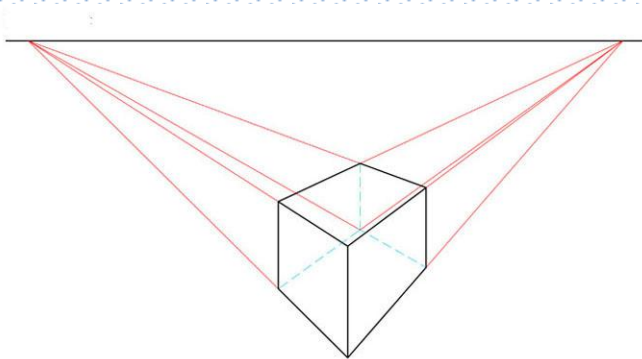

The Mathematics of Perspective Drawing: From Vanishing Points to Projective Geometry

Perspective, from the Latin *perspecta*, which means 'to look through'

The Mathematics of Perspective Drawing: From Vanishing Points to Projective Geometry

Perspective, from the Latin *perspecta*, which means 'to look through'

Look through a pane of glass at an object on the other side,

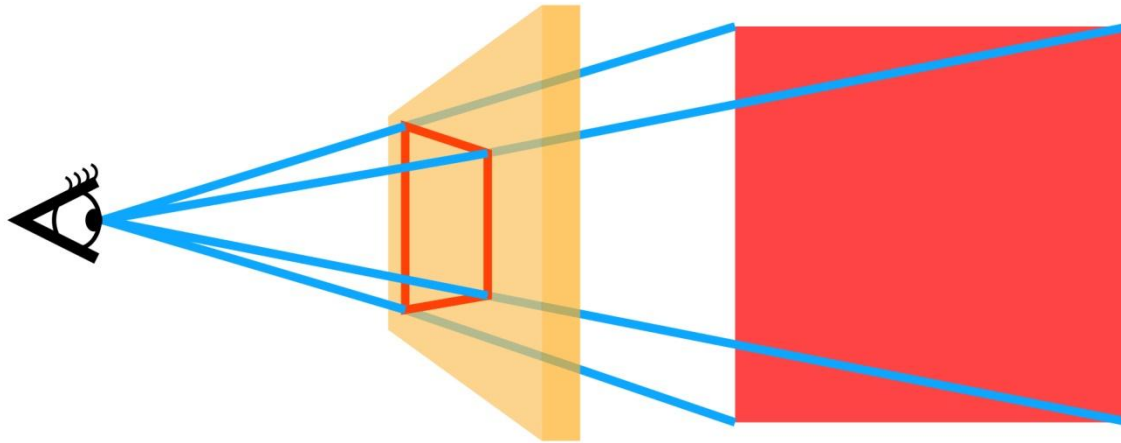

The image we see traces out a shape on the glass

We would like to 'trace' this image onto the window; this creates a 2 dimensional representation ('rendering') of the 3 dimensional scene – a painting!

Basis Of Perspective – Lines Of Sight Through A Picture Plane [19]

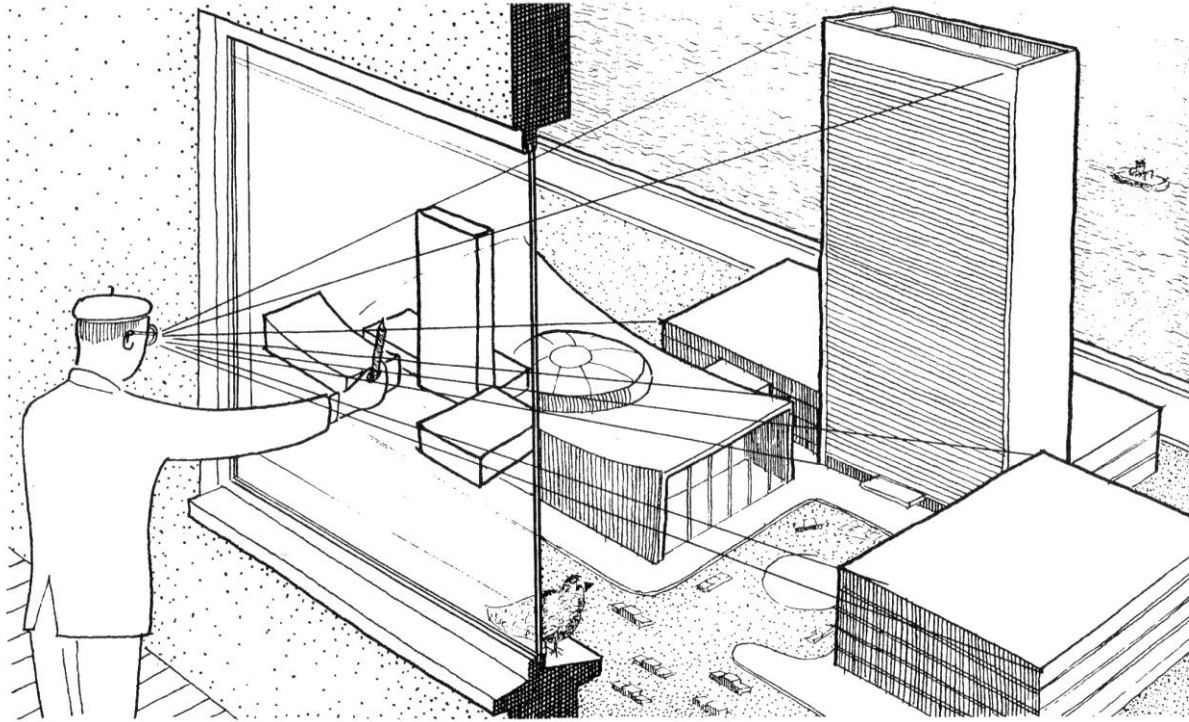

Different plane, different perspective...

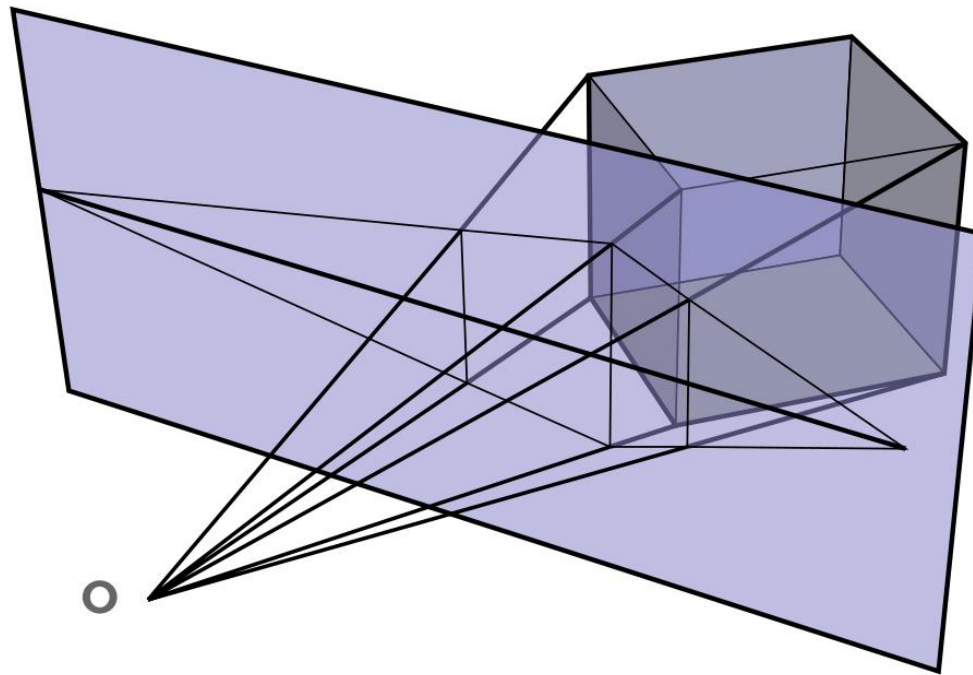

Humans have been making paintings since the beginning of time. Conceptual, metaphorical, but not realistic.

Cave painting. Libyan desert, 7000 BC



It took them a long time to figure out how to realistically create a 2 dimensional image of the 3 dimensional world ('realism'). Even in the 14th Century paintings were not too realistic (however, they were very conceptual)

Ambrogio Lorenzetti (Italian) 1290 - 1348



Giotto di Bondone (Italian) 1267 - 1337



12th Century, Song Dynasty

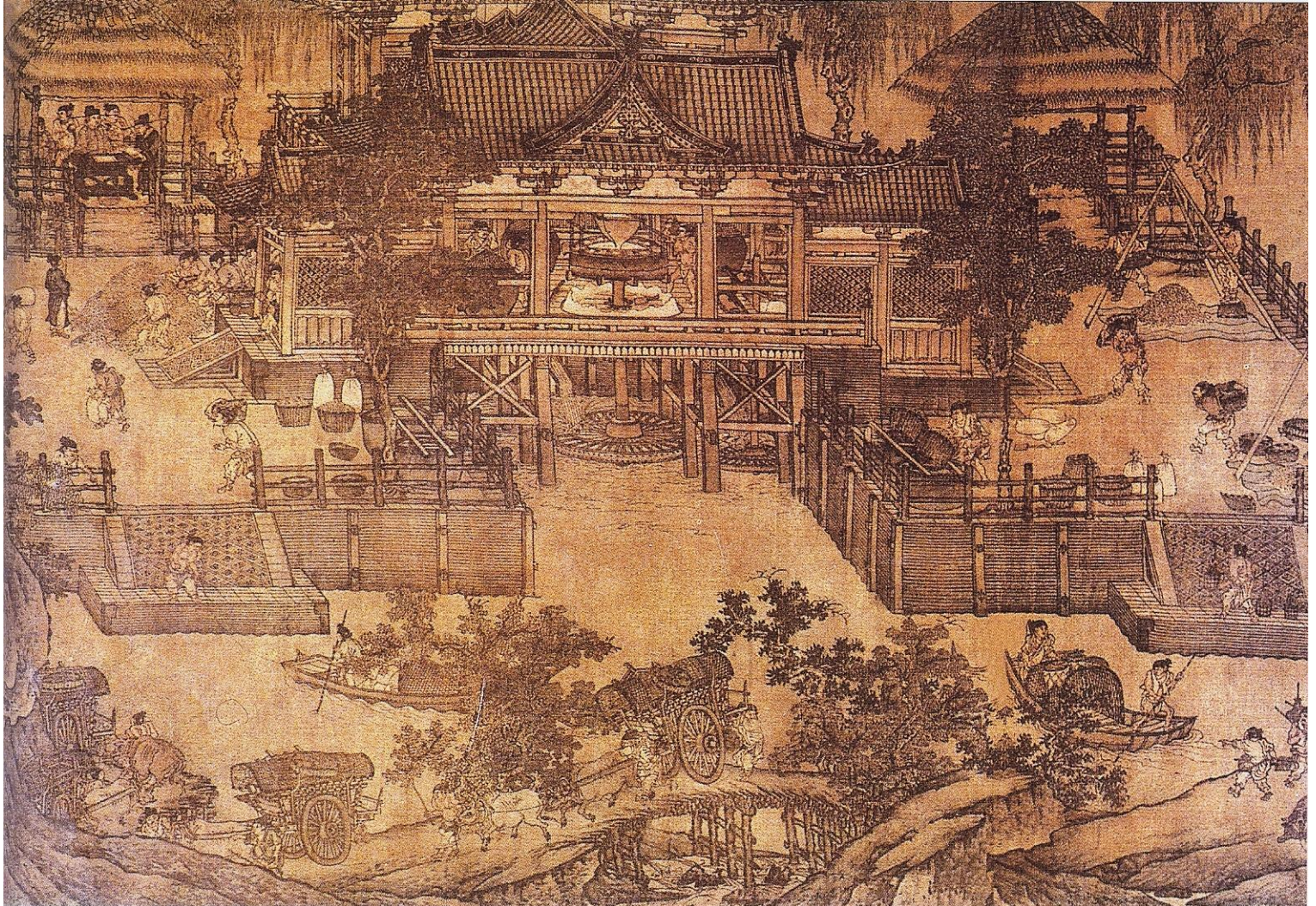

In the 15th Century (Renaissance) painters began to understand how to make realistic paintings by introducing the third dimension into their renderings ('realism').

Raffaello (Raphael) Sanzio da Urbino (Italian) 1483 – 1520

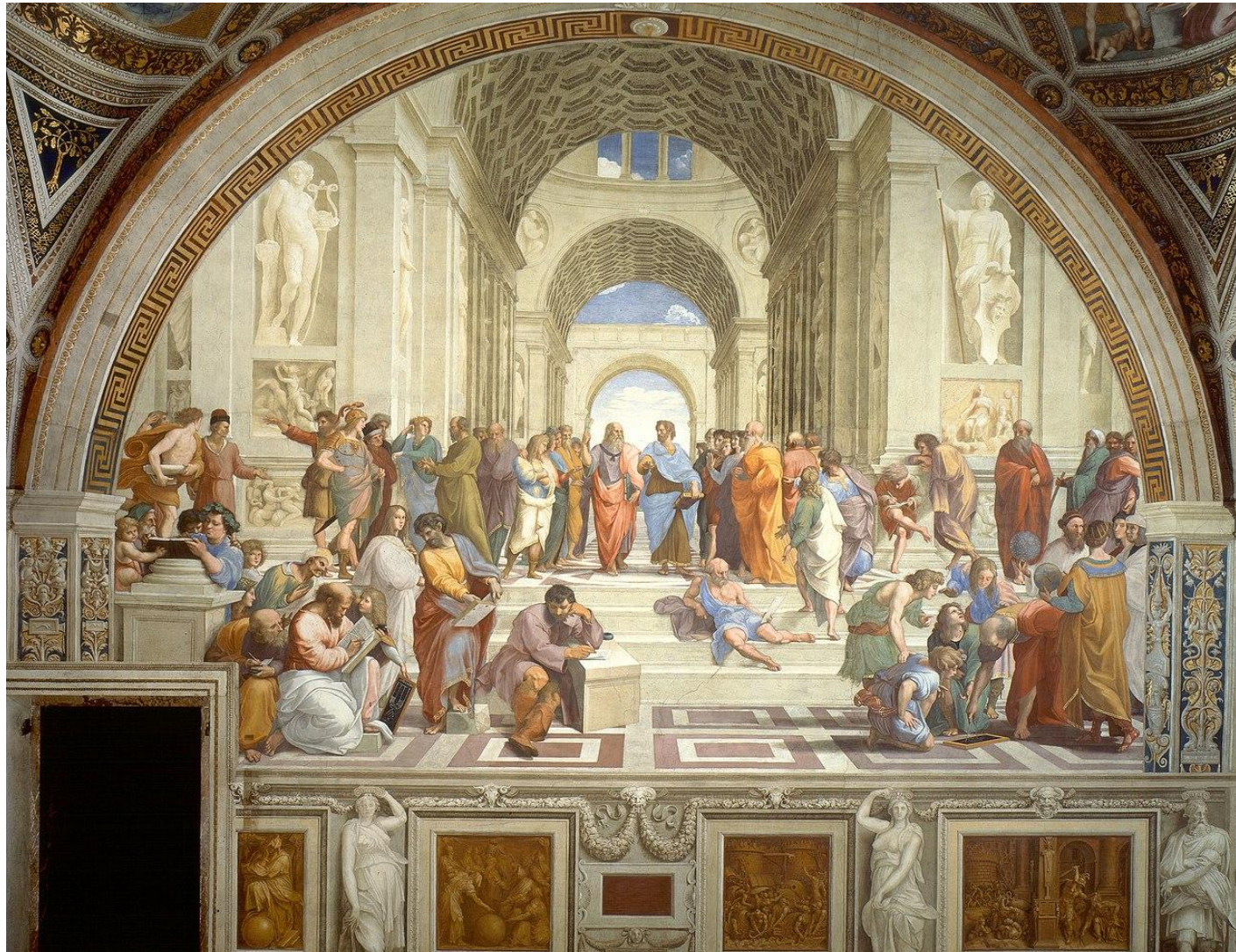

Raphael



Pietro Perugino (Italian) 1452 - 1523



Georges Seurat



One technique; trace the scene onto a translucent paper while maintaining a fixed point of view.



Figure 19. Dürer: The Designer of the Sitting Man

Tracing a scene on a window makes a realistic painting...

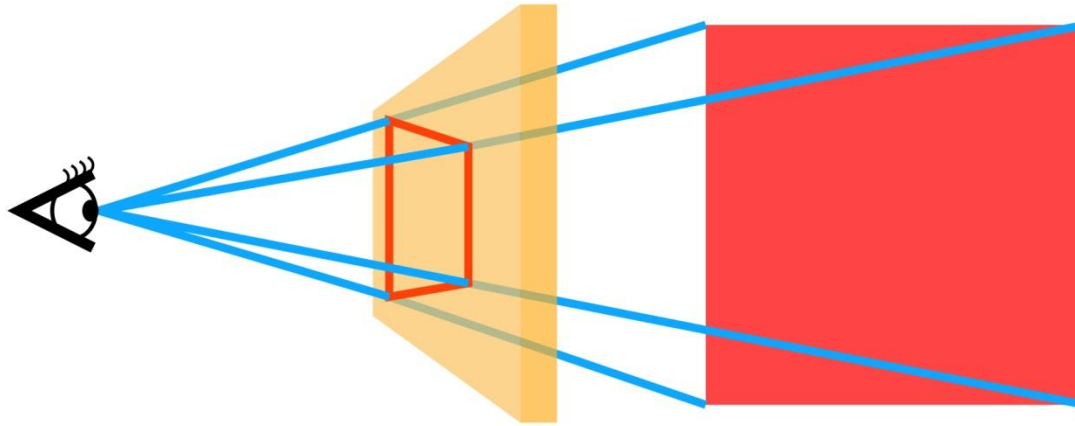

But how to do this when you don't have a scene to copy from?
What are the rules?

Furthermore, objects may appear 'distorted' when traced out on the window. How to create the right distortion?

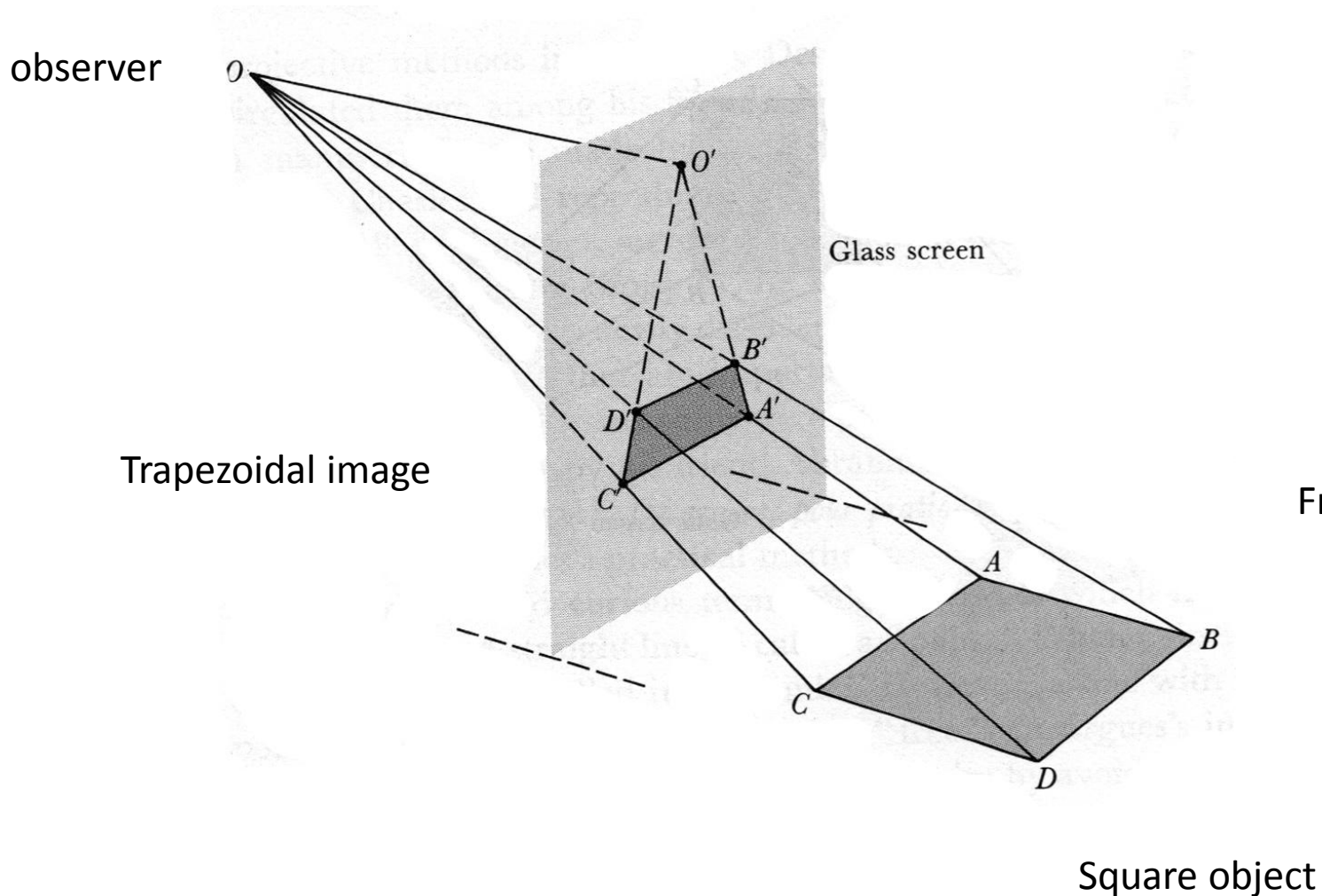

From: Kline

Tracing a scene on a window makes a realistic painting...

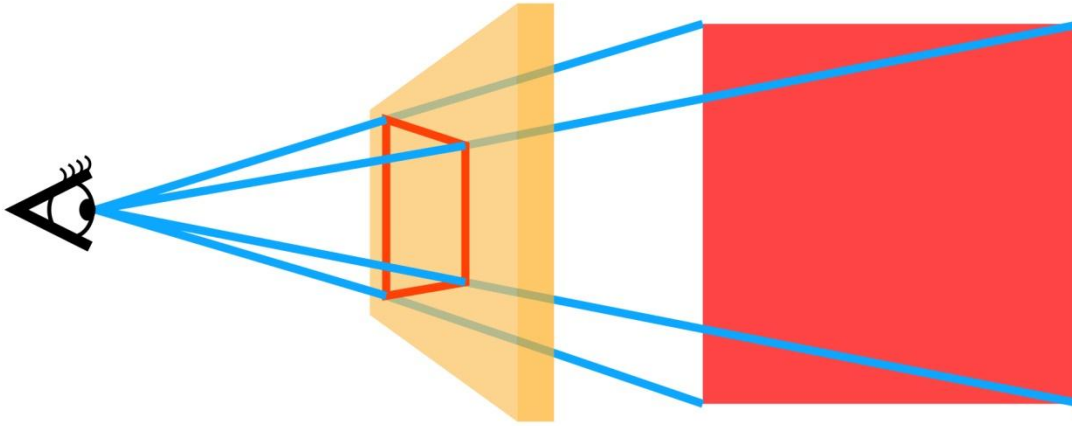

But how to do this when you don't have a scene to copy from?

Two Principles of Perspective Drawing:

1. Parallel lines meet at infinity: Vanishing points
2. Objects farther away appear smaller: Diminution of size

Filippo Brunelleschi (1377 – 1446) was one of the first to discover the rules of perspective. He used a mirror to demonstrate the accuracy of his paintings.

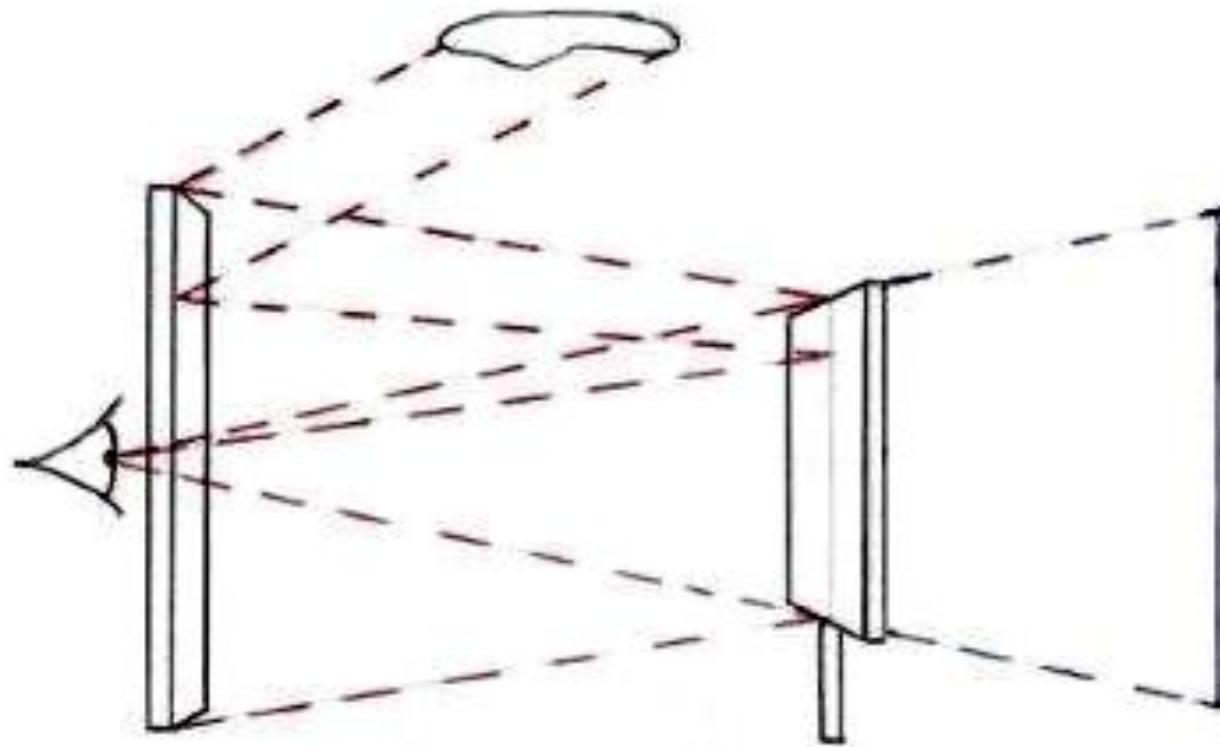

Using vanishing points and the diminution (shrinking) of sizes of distant objects create a sense of depth.



From: D'Amelio

Vanishing points; one technique for creating perspective.

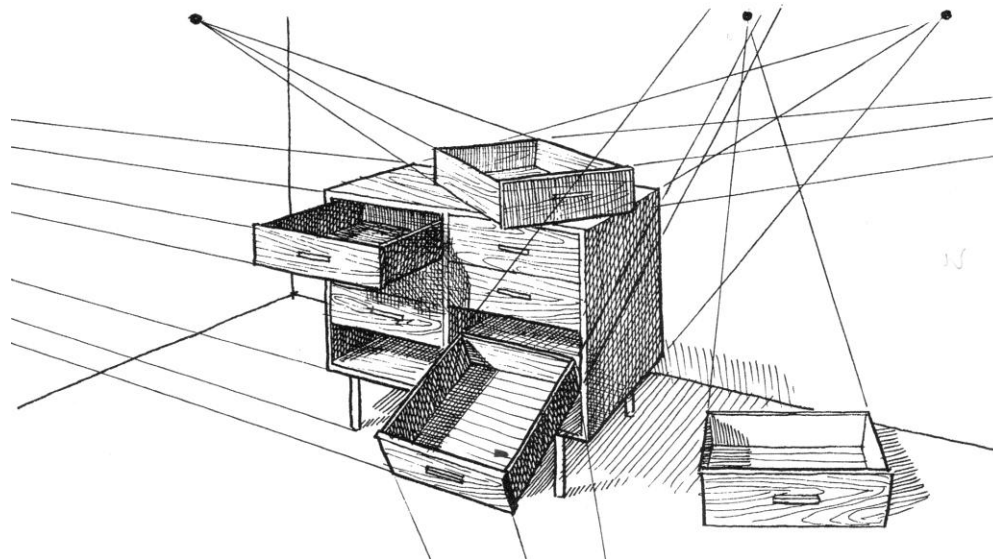
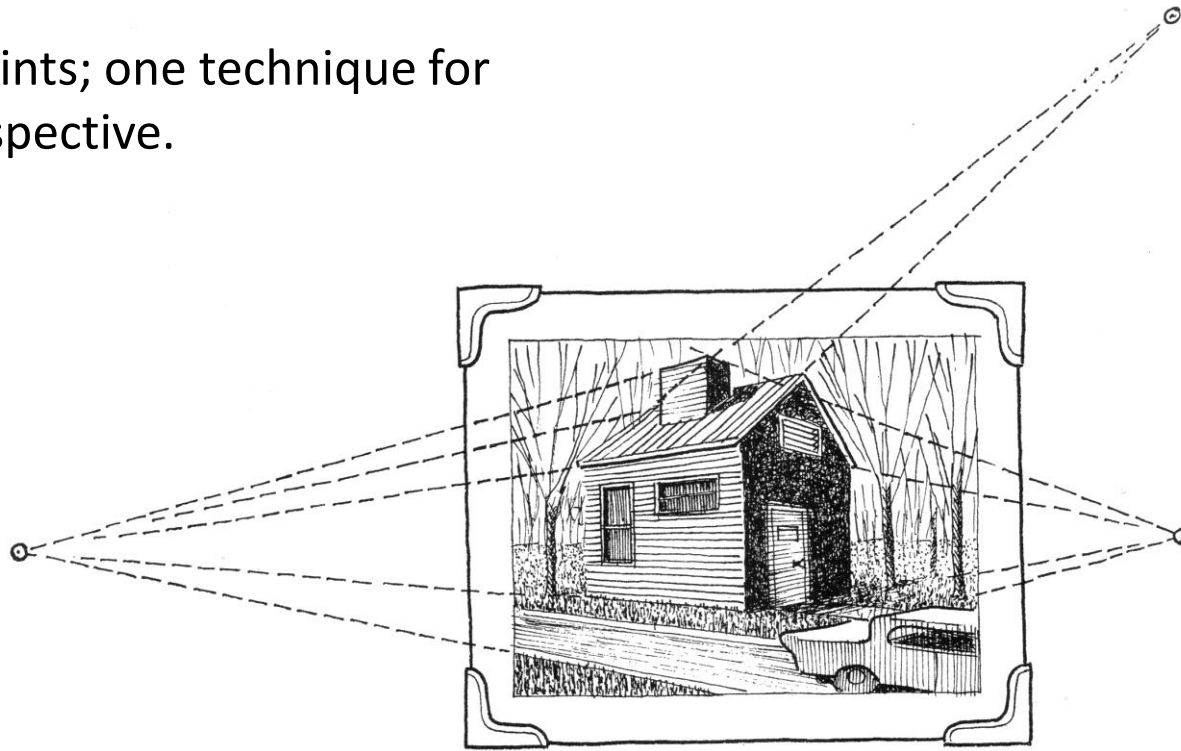

From: D'Amelio

Photographs, of course, capture perspective accurately.



Are there vanishing points here?



Yes, one in the centre





Several vanishing points.

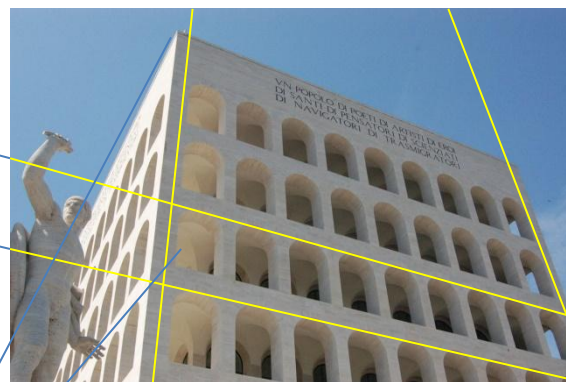

The horizon: Where the observer's eye level is



From: D'Amelio

Vanishing points: Parallel lines appear to converge
(because the distance between them is diminishing with distance)

horizon

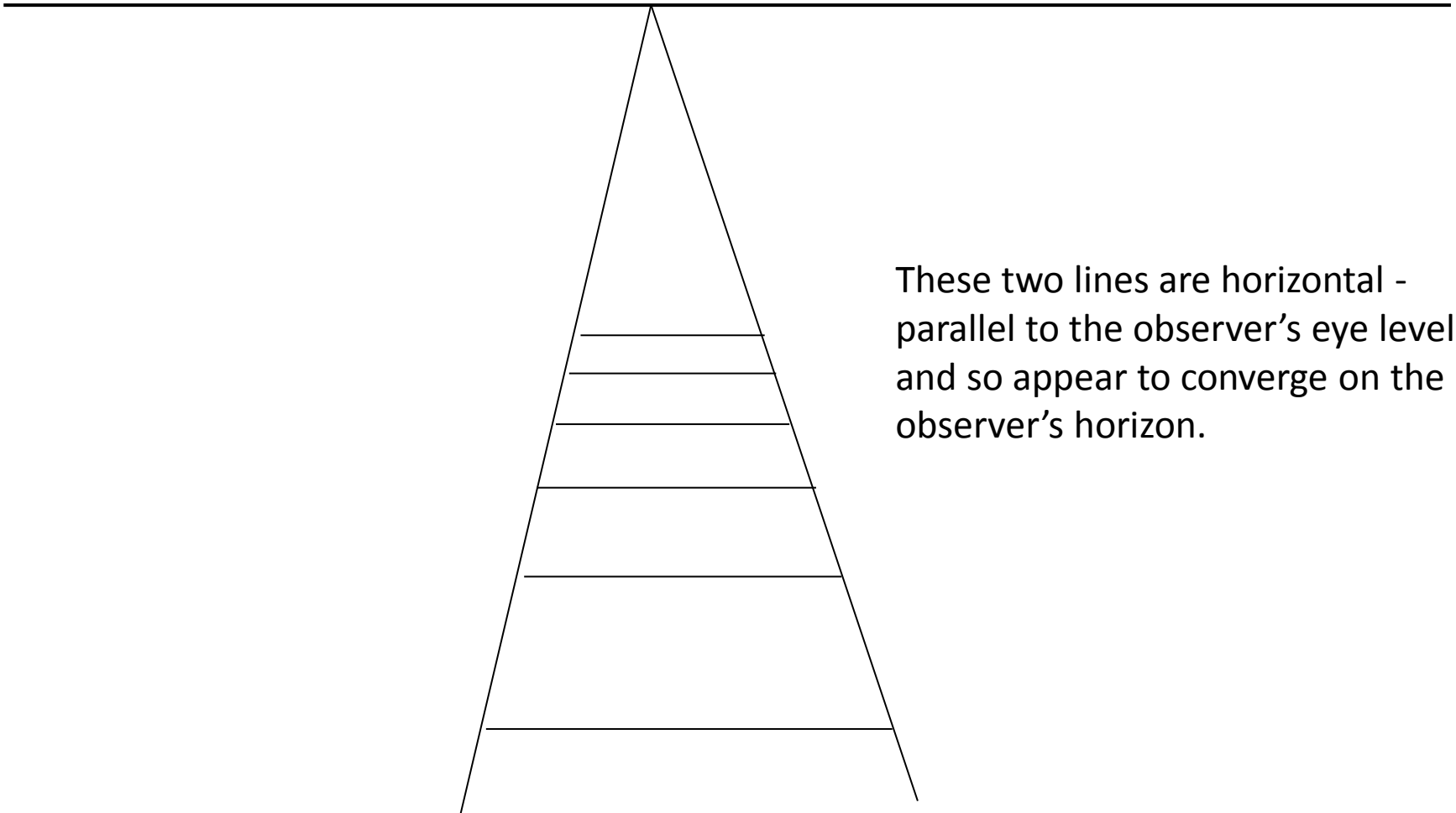

These two lines are horizontal -
parallel to the observer's eye level -
and so appear to converge on the
observer's horizon.

Vanishing points

All lines in a given direction appear to converge to the same point

horizon

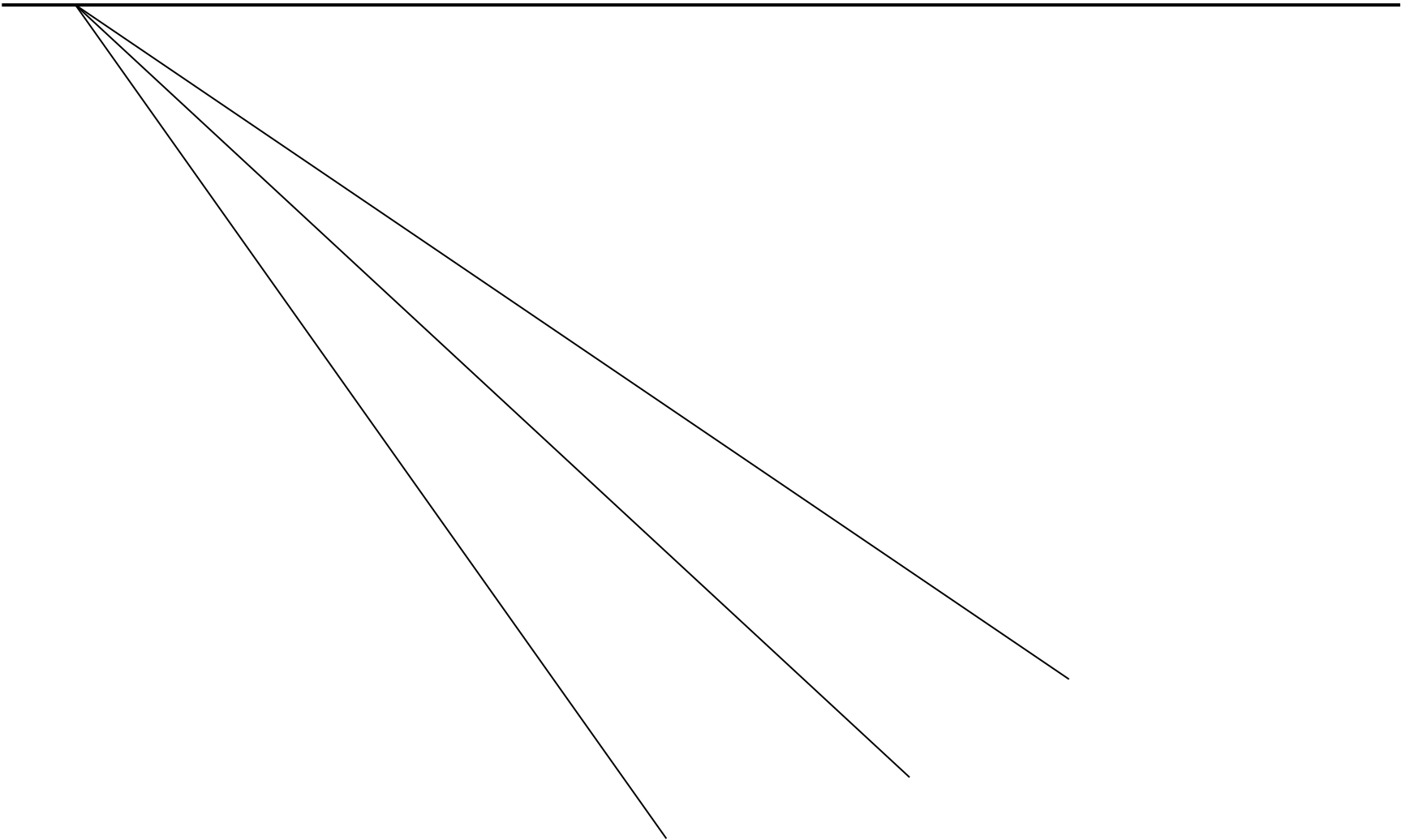

Vanishing points

All lines in a given direction appear to converge to the same point

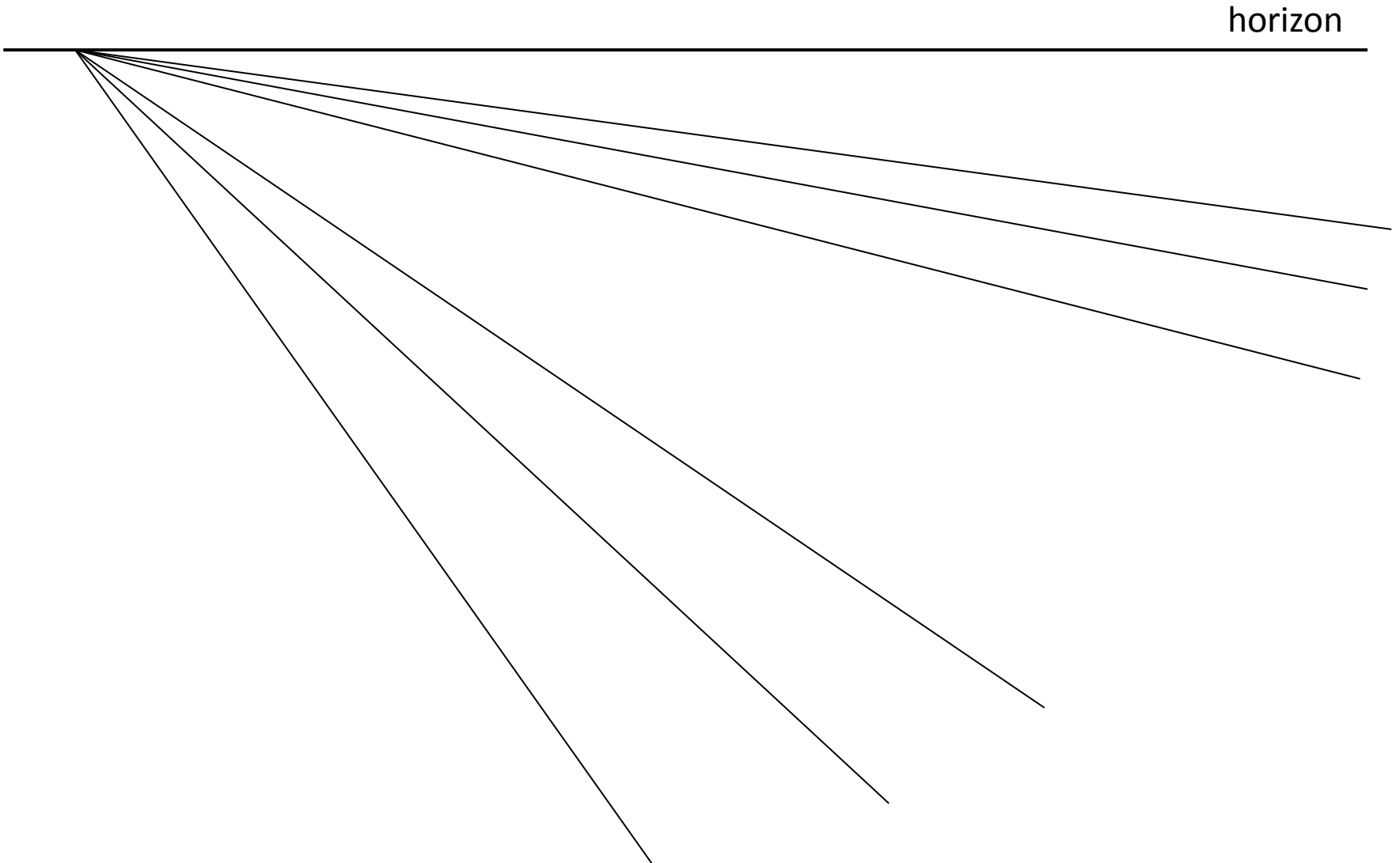

Vanishing points

All parallel lines appear to converge

horizon

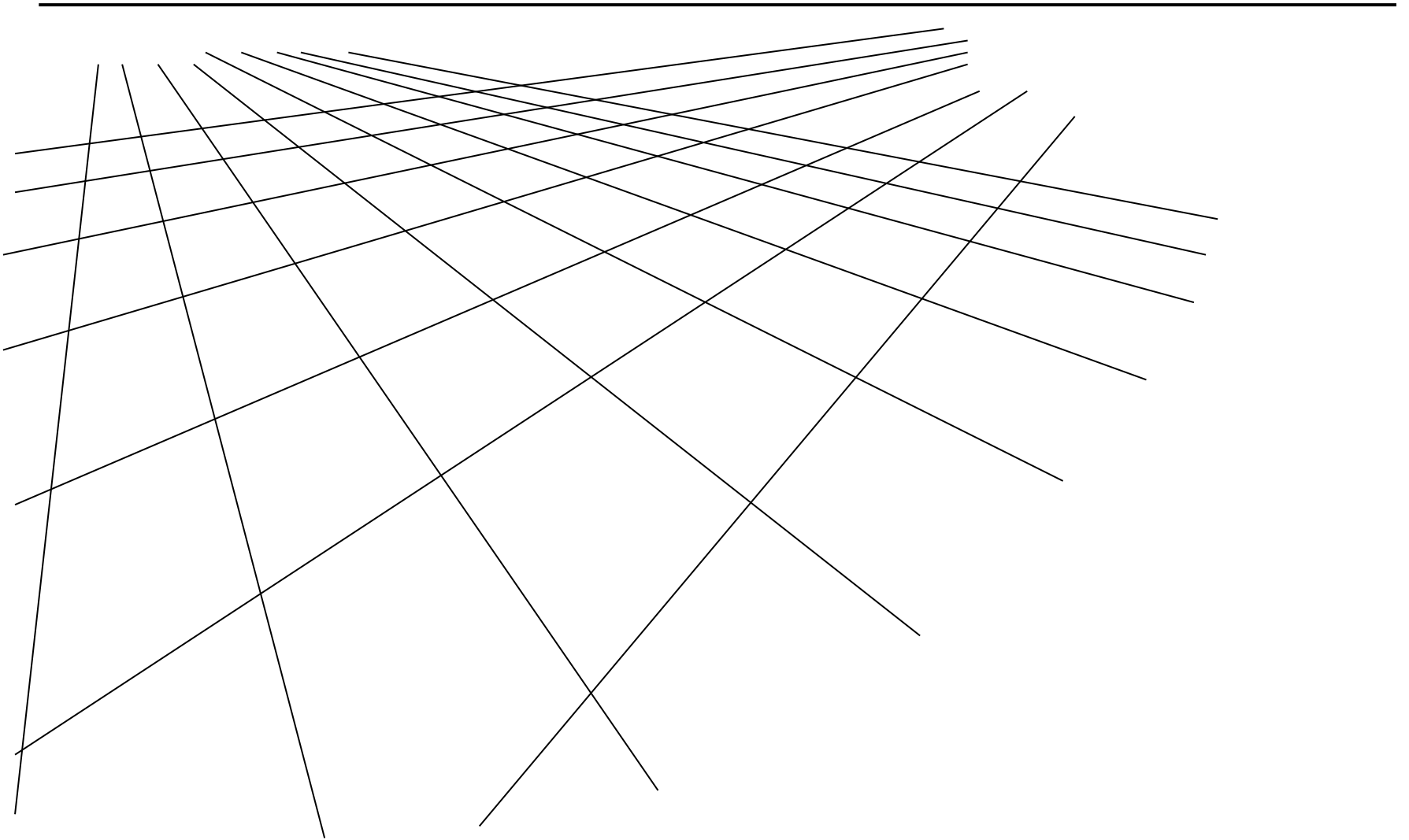

Vanishing points

All parallel lines appear to converge

horizon

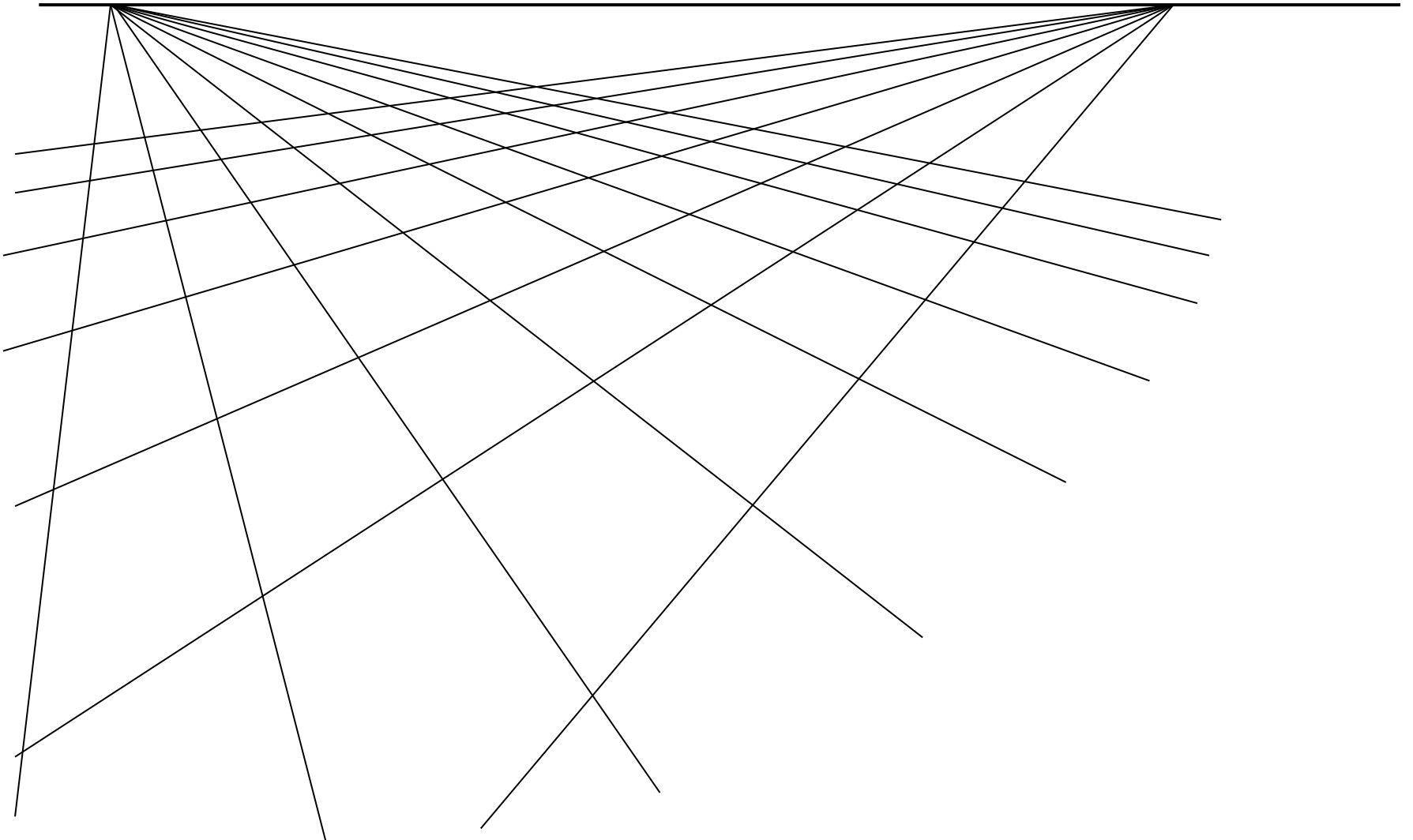

There are vanishing points for every direction;
These lines are horizontal

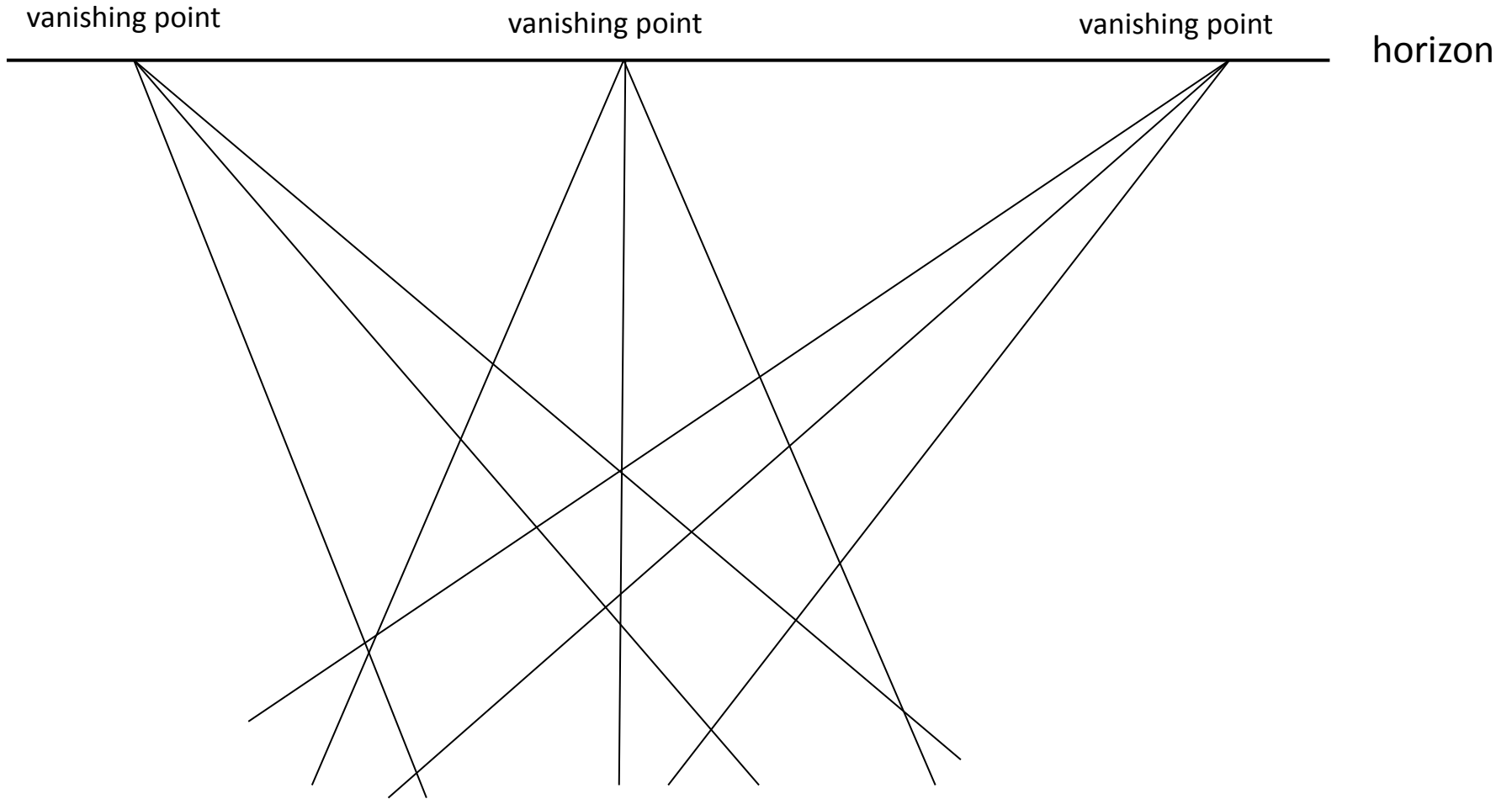

There are vanishing points for every direction;
These lines are not horizontal

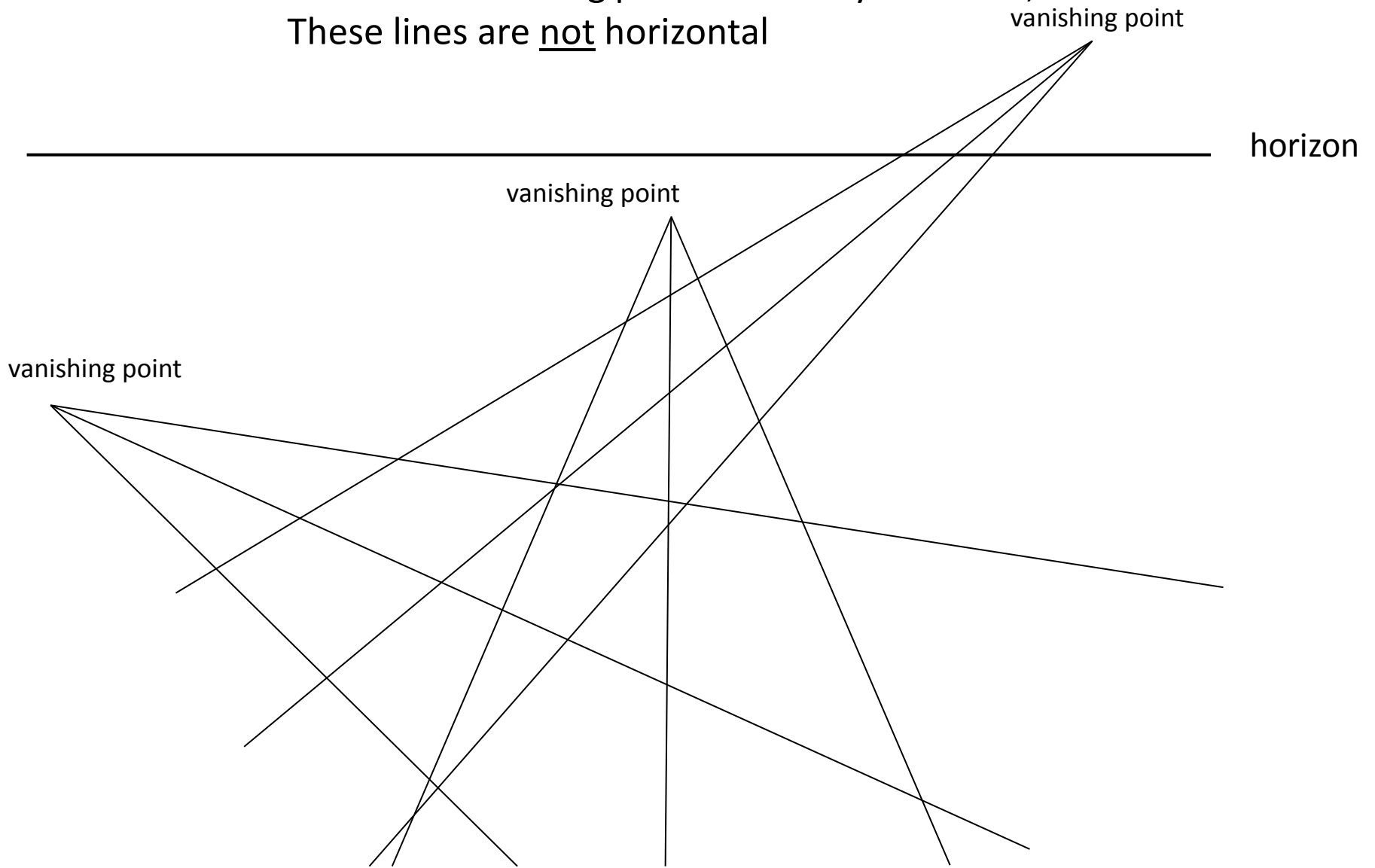

Vanishing points

Use of vanishing points gives the impression of depth in an image

Vanishing Point

Vanishing Point

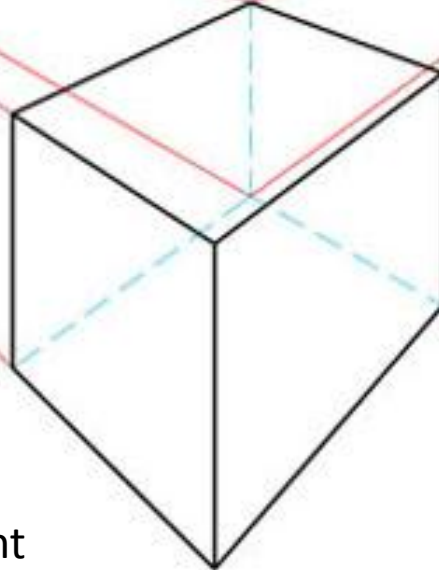

Notice; the top and bottom surfaces are parallel to the observers line of sight

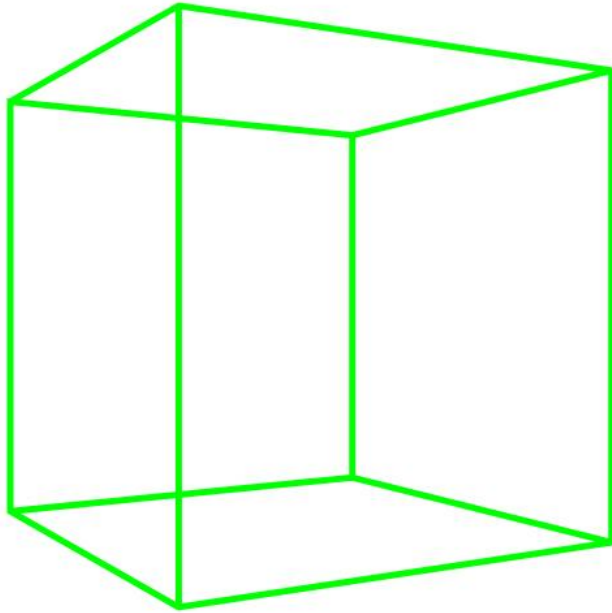

Realistic 3D sketches
adhere to the principles of
perspective

But need enough vanishing
points....

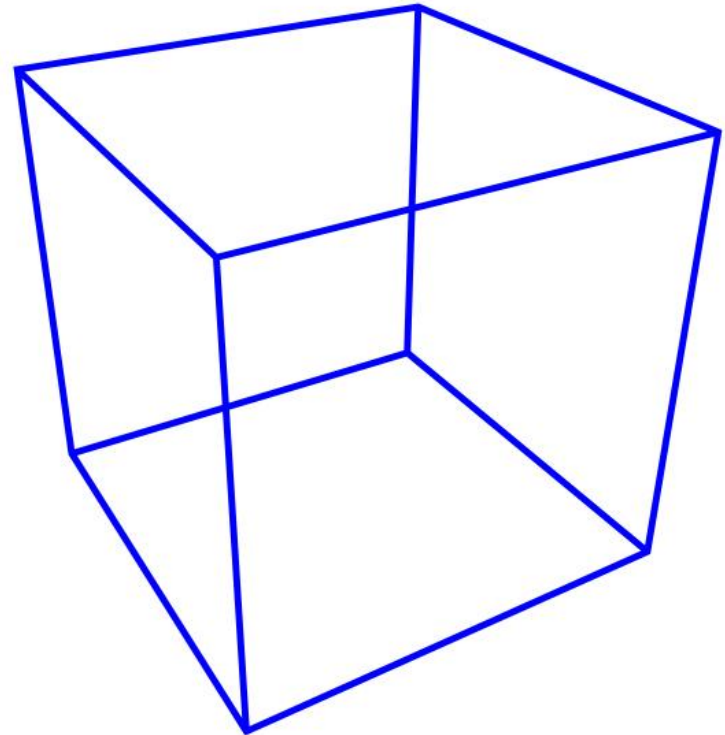

Vanishing points here?

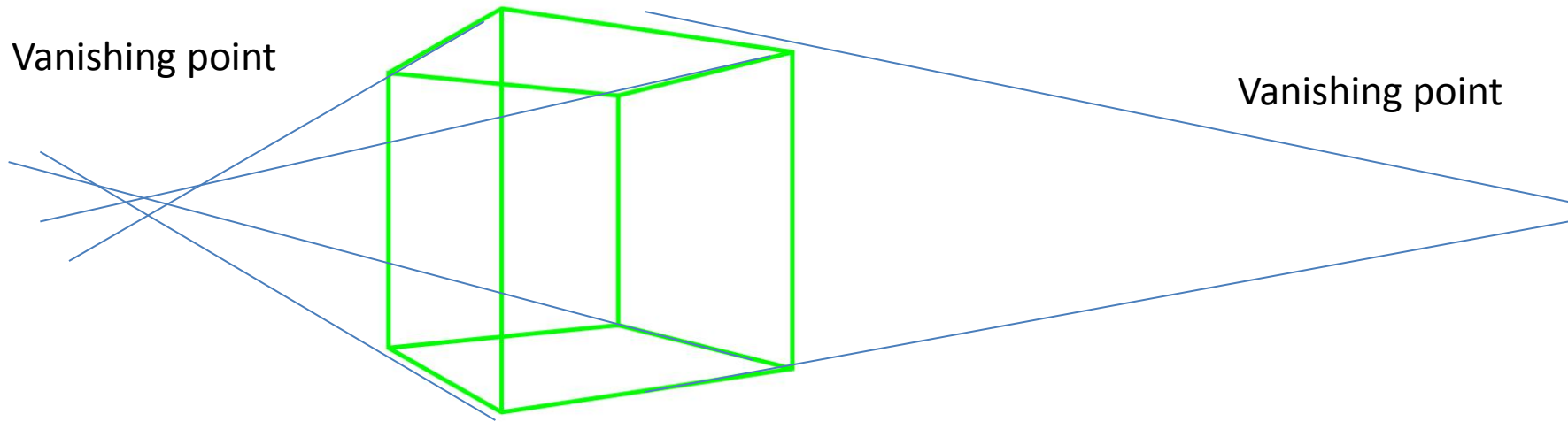

2 vanishing points:
2 point perspective

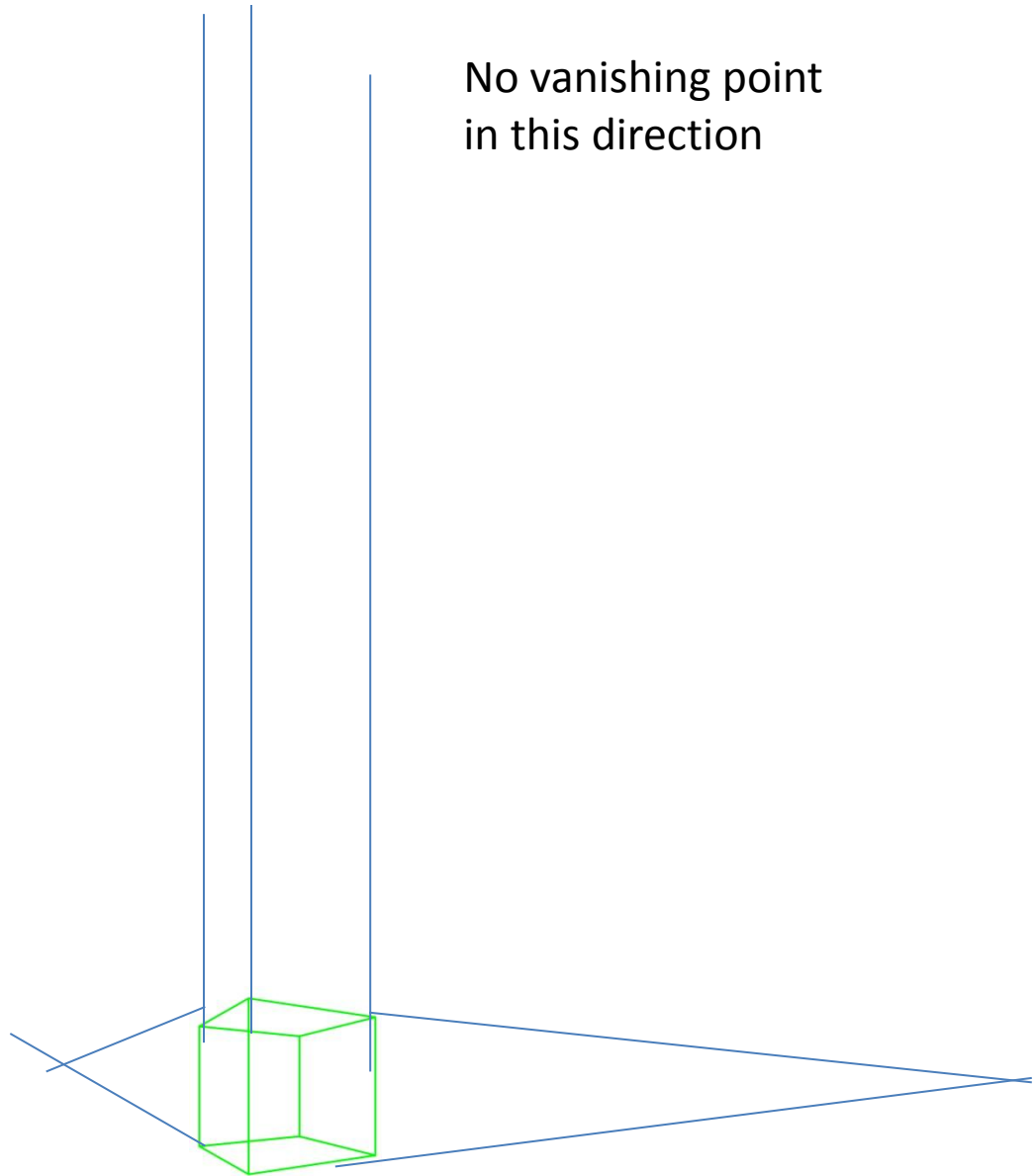

No vanishing point
in this direction

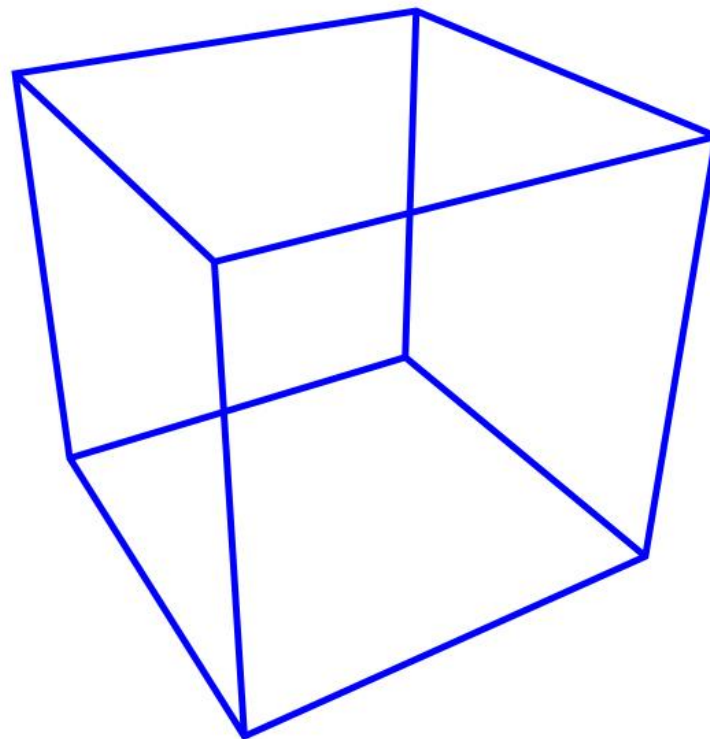

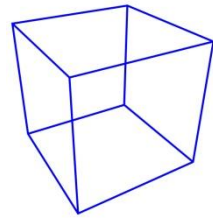

Vanishing
point

Vanishing
point

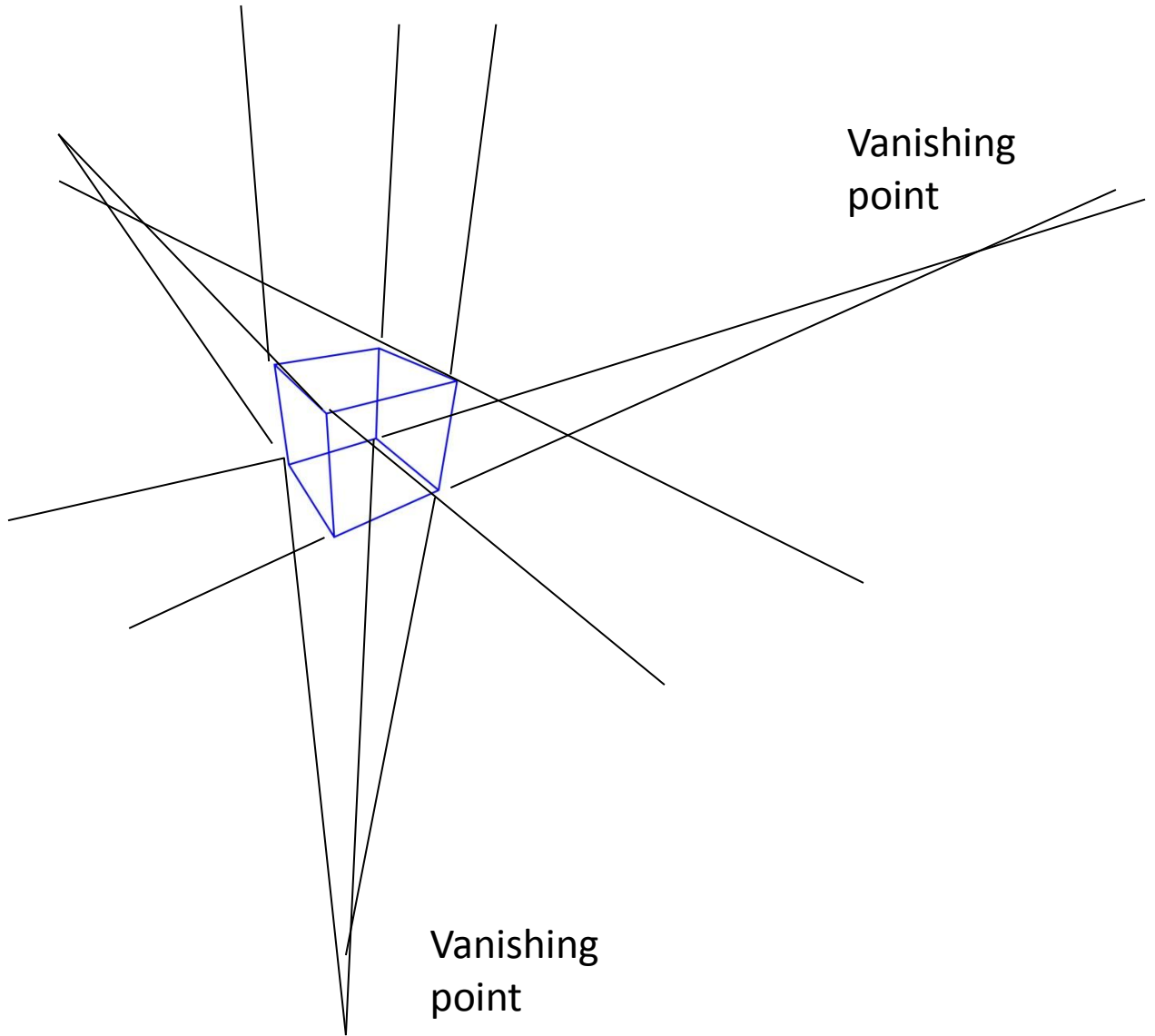

Vanishing
point

3 vanishing points:
3 point perspective

Two Principles of Perspective Drawing:

1. Parallel lines meet at infinity: Vanishing points
2. Objects farther away appear smaller: Diminution of size

A person making a sketch by hand follows these steps:

1. Draw the horizon (Where is the observer looking?)
2. Determine vanishing points of any straight lines appearing in the scene
3. More distant objects appear smaller than closer ones

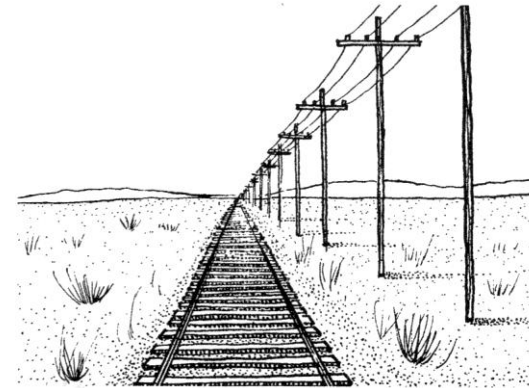
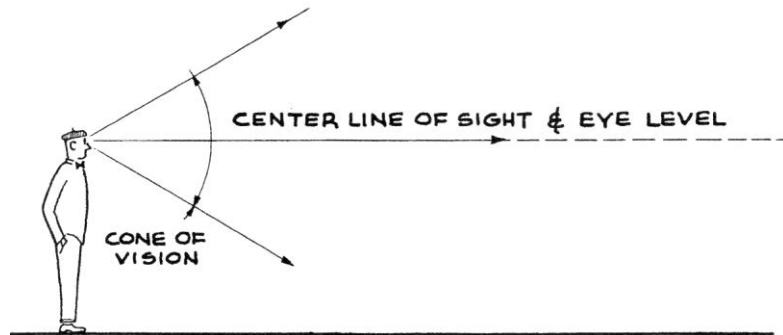

From: D'Amelio

How to code this mathematically so that we can program a computer to create realistic 2 dimensional images?

First: Where are the vanishing points?

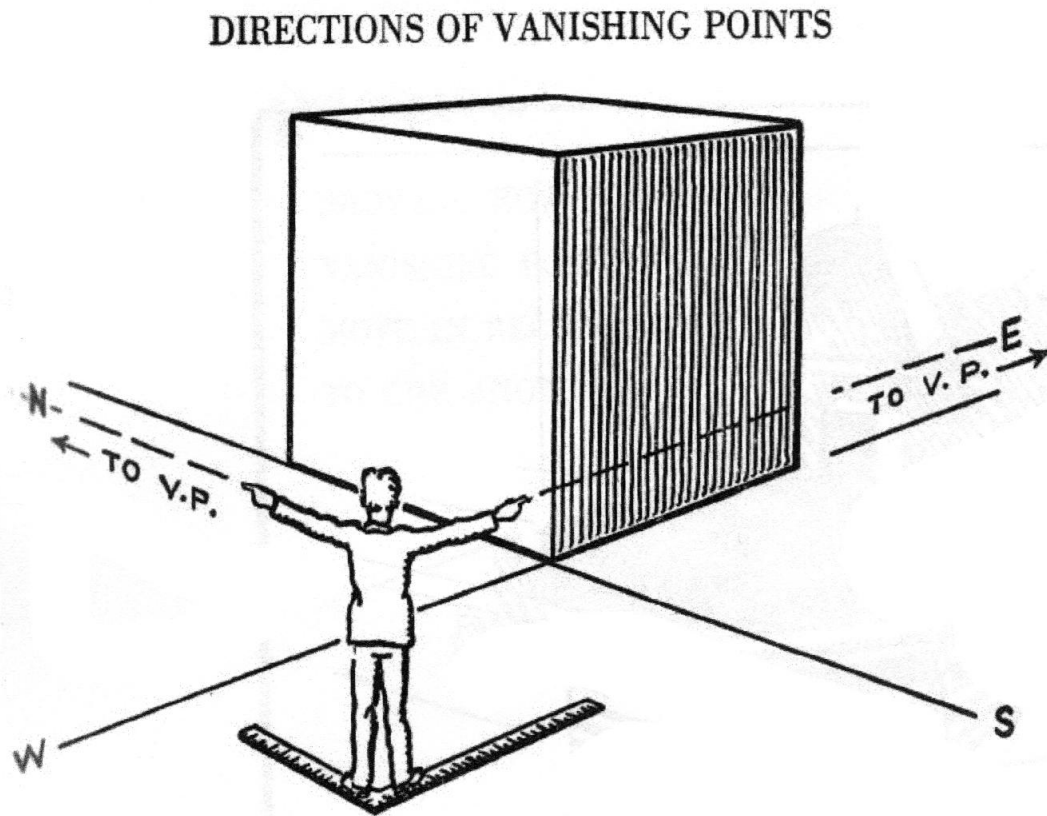

From: D'Amelio

Determining the vanishing points mathematically

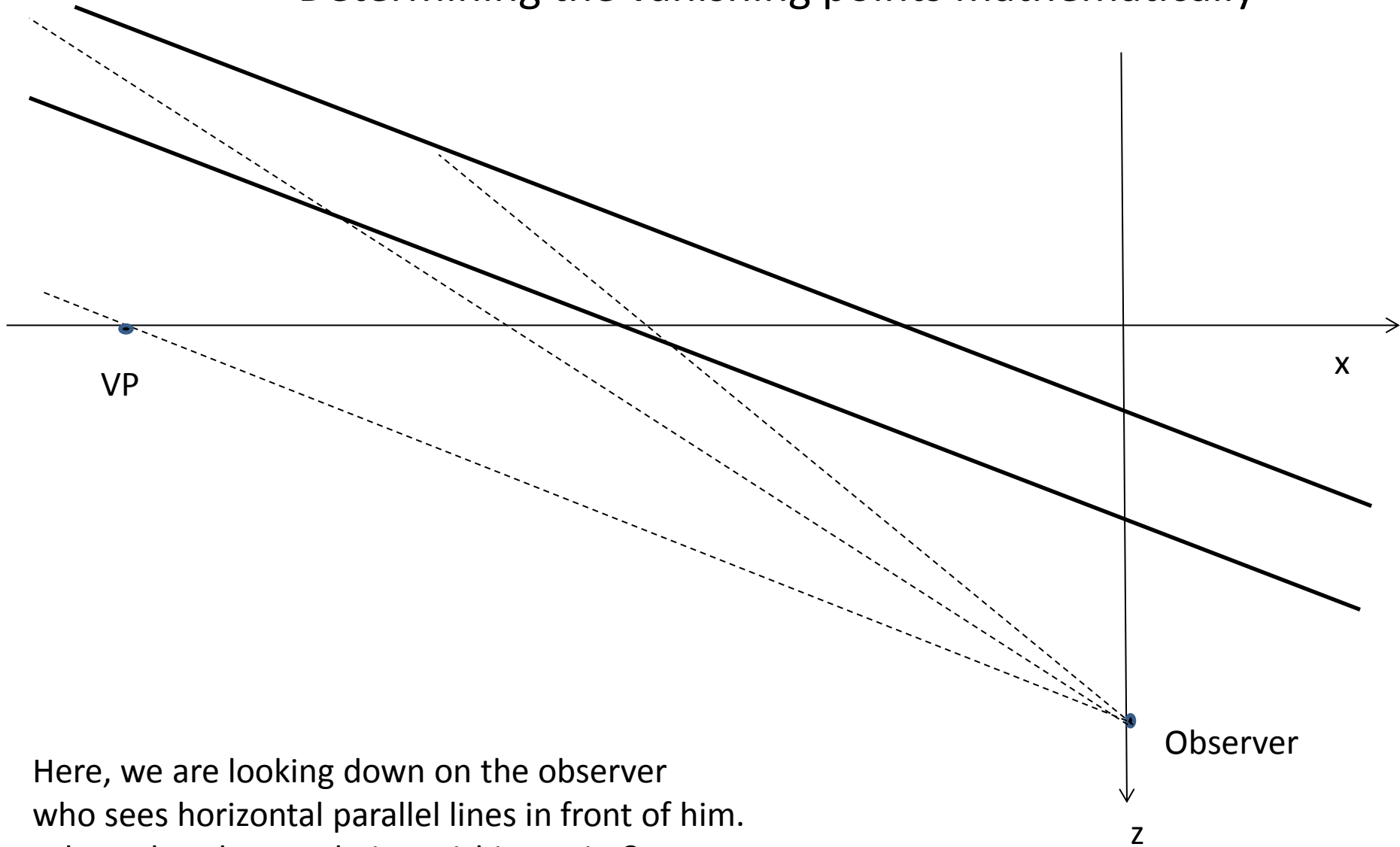

Here, we are looking down on the observer who sees horizontal parallel lines in front of him. Where does he see their vanishing point?

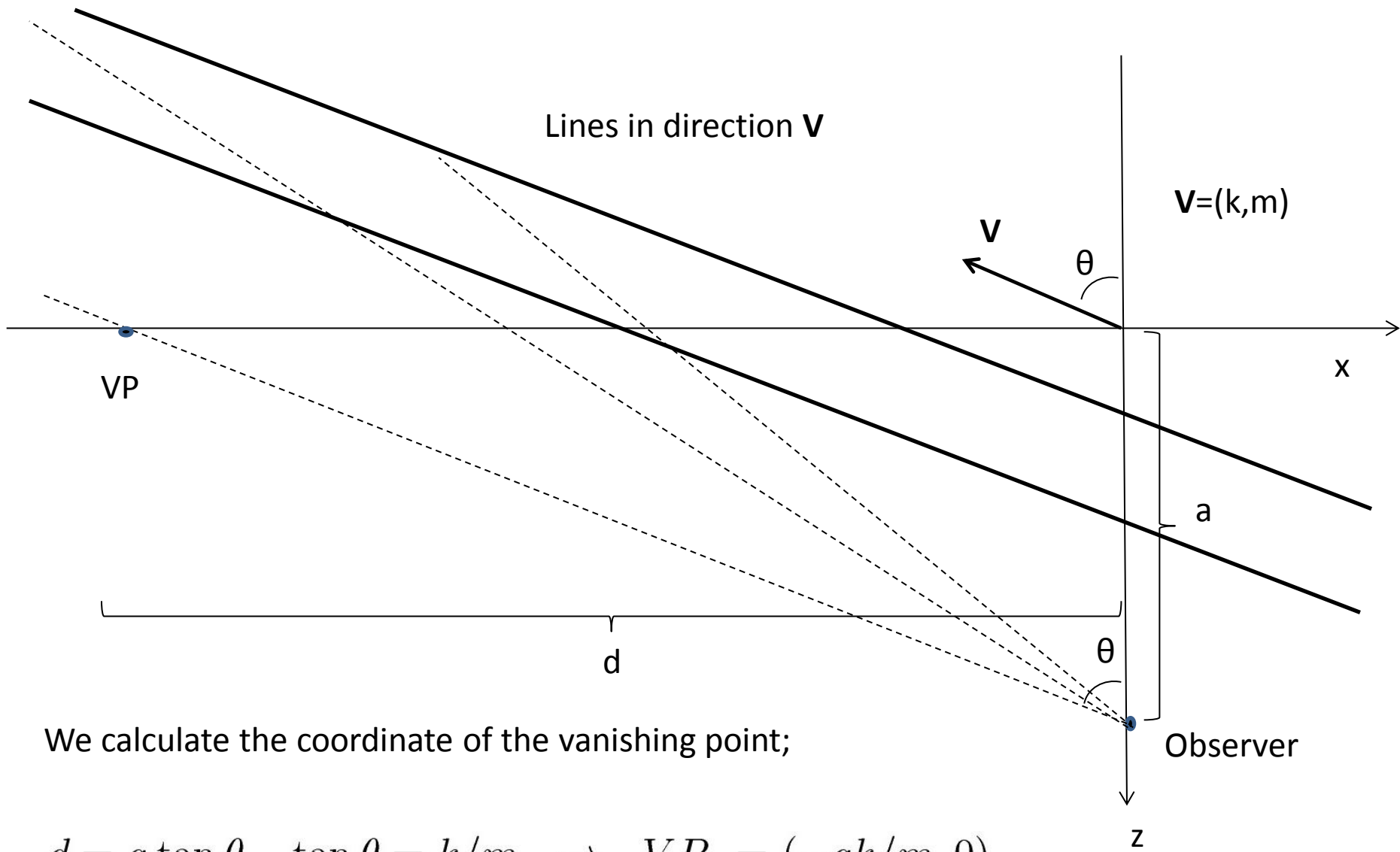

We calculate the coordinate of the vanishing point;

$$d = a \tan \theta, \quad \tan \theta = k/m \quad \rightarrow \quad VP_{\mathbf{v}} = (-ak/m, 0)$$

Next: Calculate diminution of size

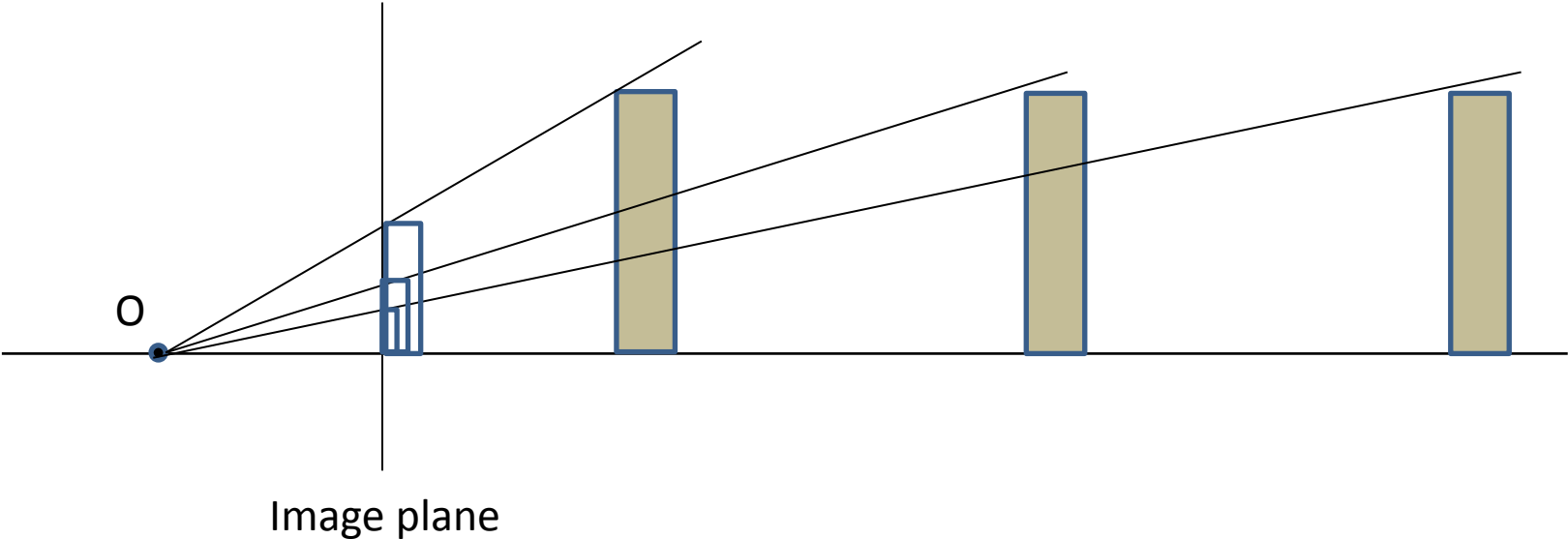

Diminution of size

h is the apparent size of the object on the image plane, L is its actual size

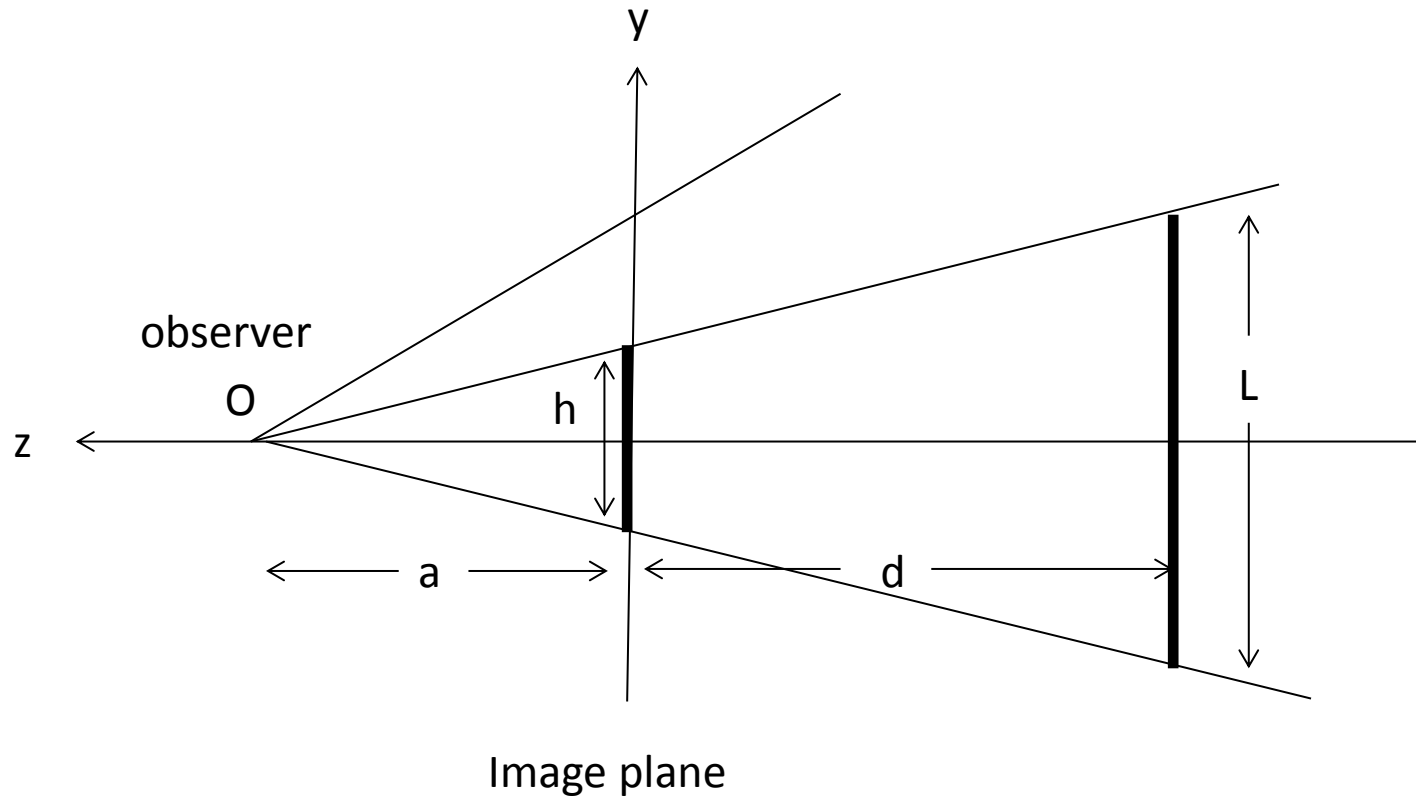

Similar triangles; $\frac{h/2}{a} = \frac{L/2}{a+d} \rightarrow h = \frac{a}{a+d} L$

Diminution of size: what we calculate

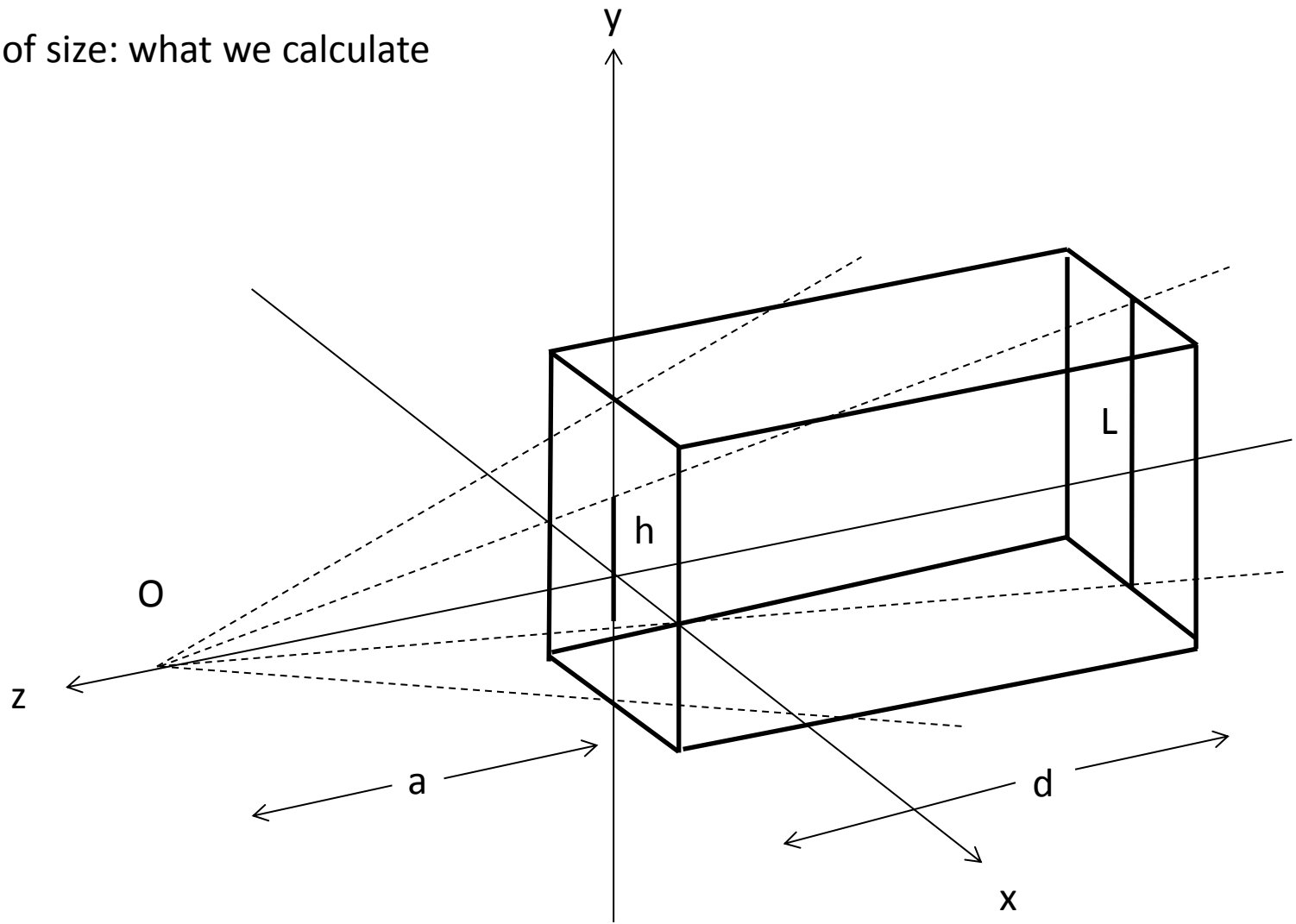

Diminution of size: what we draw

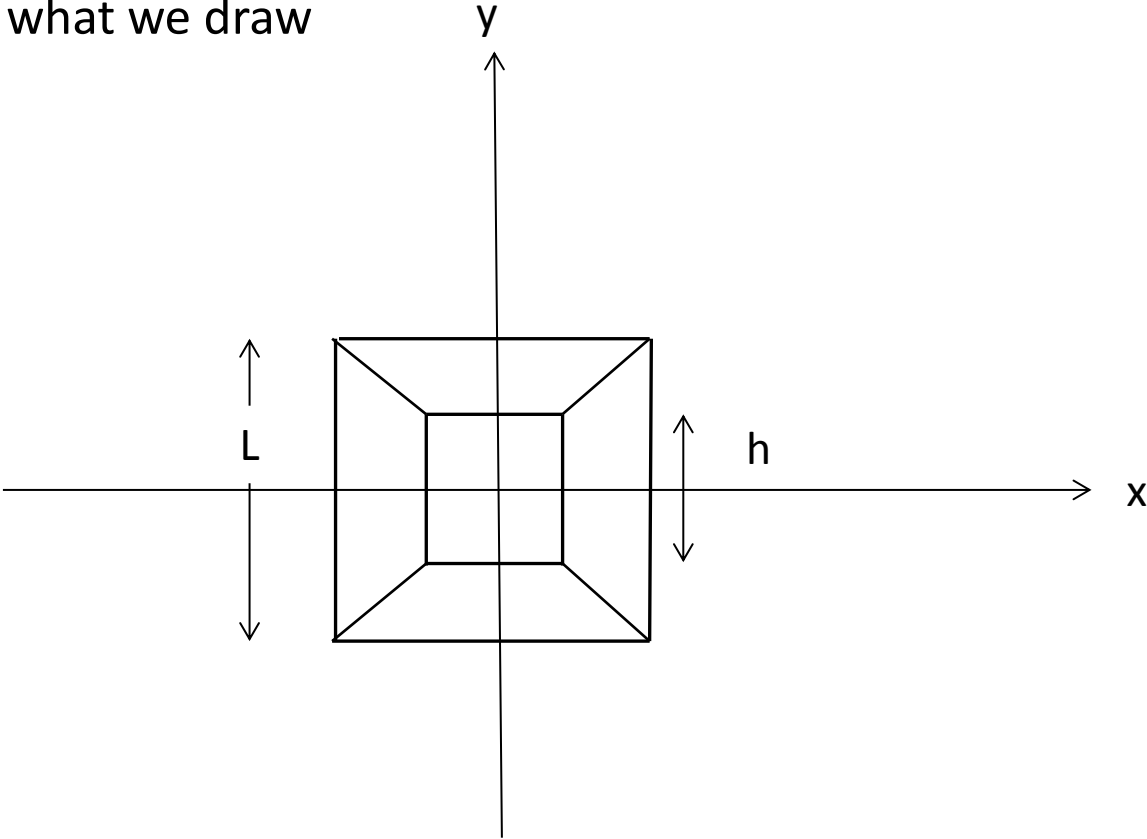

1 point perspective

Diminution of size: what we draw

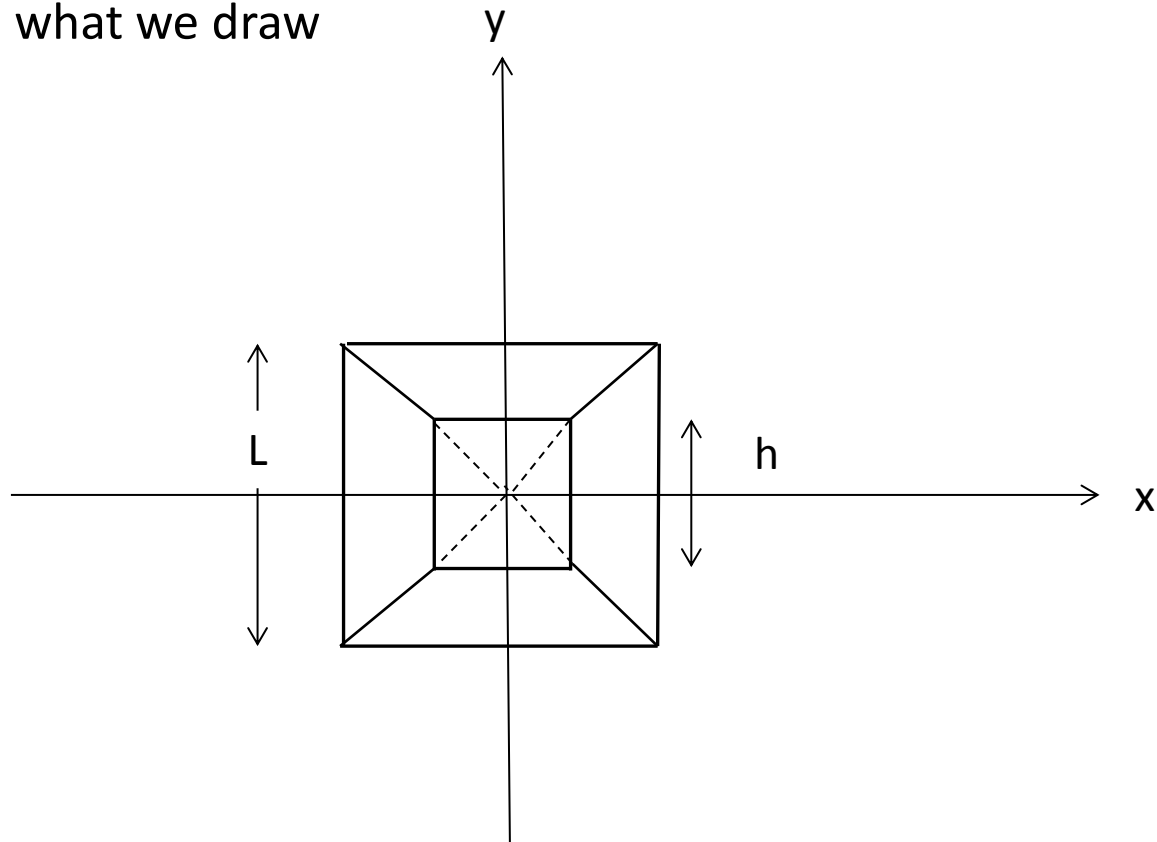

1 point perspective; notice that lines parallel to the observer's line of sight appear to converge at the origin

Perspective rendering is accomplished in computer graphics using linear algebra.

Homogeneous coordinates and homogeneous transformations

Homogeneous coordinates and homogeneous transformations.

Homogeneous coordinates in 2 dimensions; $(x,y) \rightarrow (x,y,z)$;

Points along a line are equivalent.

'Physical' points are those with $z=1$. After transforming a point $(x,y,1) \rightarrow (x',y',r')$,

'ray trace' back to physical space; $(x',y',r') \rightarrow (x'/r', y'/r', 1)$

Homogeneous transformations
via 3X3 matrices;

$$\begin{bmatrix} & & a \\ & M_2 & b \\ d & e & c \end{bmatrix}$$

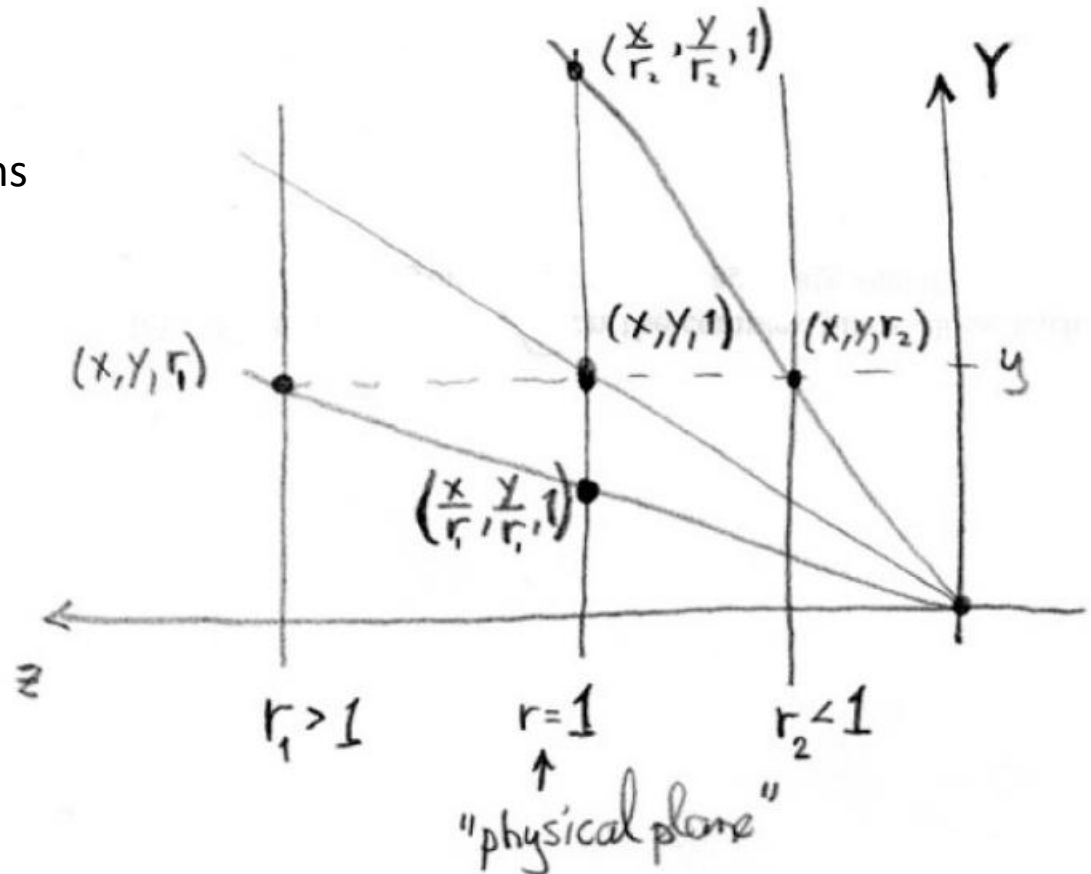

A general 2D homogeneous matrix is a 3×3 matrix with entries

$$\begin{bmatrix} a & b & m \\ c & d & n \\ p & q & r \end{bmatrix}$$

We have discussed the roles the entries a, b, c, d and m, n, r play in terms of the transformations they produce, now we discuss the roles of p and q .

Consider the 2D homogeneous matrix

$$M = \begin{bmatrix} 1 & 0 & 0 \\ 0 & 1 & 0 \\ p & q & 1 \end{bmatrix}$$

Let's multiply it against a 'physical' point $\mathbf{v} = (x, y, 1)$;

$$M\mathbf{v} = \begin{bmatrix} 1 & 0 & 0 \\ 0 & 1 & 0 \\ p & q & 1 \end{bmatrix} \begin{bmatrix} x \\ y \\ 1 \end{bmatrix} = \begin{bmatrix} x \\ y \\ px + qy + 1 \end{bmatrix}$$

Now we bring this back into physical space by making the last entry 1 (divide by $px + qy + 1$);

$$\begin{bmatrix} x \\ y \\ px + qy + 1 \end{bmatrix} = \begin{bmatrix} \frac{x}{px+qy+1} \\ \frac{y}{px+qy+1} \\ 1 \end{bmatrix} = \begin{bmatrix} x' \\ y' \\ 1 \end{bmatrix}$$

This is a perspective transformation; we are looking at the resulting image as it is projected onto the slanted screen $z = px + qy + 1$ (instead of the vertical screen $z = 1$);

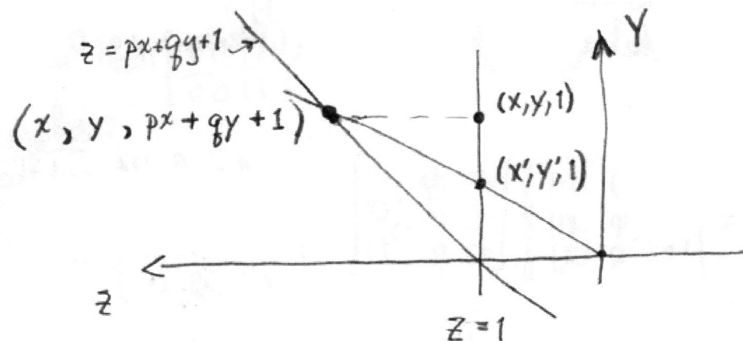

Homogeneous coordinates in 3 dimensions; $(x,y,z) \rightarrow (x,y,z,t)$.

'Physical ' space; $t=1$

General 4X4 projective matrix;

$$\begin{bmatrix} & & & m \\ & M_3 & & n \\ & & & k \\ p & q & s & r \end{bmatrix}$$

Example: Rotation about y-axis;

$$\begin{bmatrix} \cos \theta & 0 & -\sin \theta & 0 \\ 0 & 1 & 0 & 0 \\ \sin \theta & 0 & \cos \theta & 0 \\ 0 & 0 & 0 & 1 \end{bmatrix}$$

Scaling (dilation):

$$\begin{bmatrix} 1 & 0 & 0 & 0 \\ 0 & 1 & 0 & 0 \\ 0 & 0 & 1 & 0 \\ 0 & 0 & 0 & r \end{bmatrix} \begin{bmatrix} x \\ y \\ z \\ 1 \end{bmatrix} = \begin{bmatrix} x \\ y \\ z \\ r \end{bmatrix} \longrightarrow \begin{bmatrix} x/r \\ y/r \\ z/r \\ 1 \end{bmatrix}$$

Translation:

$$\begin{bmatrix} 1 & 0 & 0 & m \\ 0 & 1 & 0 & n \\ 0 & 0 & 1 & k \\ 0 & 0 & 0 & 1 \end{bmatrix} \begin{bmatrix} x \\ y \\ z \\ 1 \end{bmatrix} = \begin{bmatrix} x + m \\ y + n \\ z + k \\ 1 \end{bmatrix}$$

Implementing perspective rendering on a computer:

Create the 3D image by specifying the 3D coordinates (x,y,z) of all the objects.

Homogenize the coordinates: $(x,y,z) \rightarrow (x,y,z,1)$

Apply a perspective 4X4 homogeneous linear transformation T to all the points in the image: $T: (x, y, z, 1) \rightarrow (x_1, y_1, z_1, w)$

'Ray trace' back the resulting homogeneous points to 'physical space';
 $(x_1, y_1, z_1, w) \rightarrow (x', y', z', 1)$, where $x'=x_1/w$, $y'=y_1/w$, $z'=z_1/w$

Orthographically (orthogonally) project onto the xy-plane: $(x',y',z',1) \rightarrow (x',y')$

The collection of points (x',y') is the perspective 2D rendering of the 3D scene

Procedure for performing 3D homogeneous transformations:

- (i) apply a 3D homogeneous (4×4) transformation.
- (ii) convert to physical space (make $t = 1$)
- (iii) render the 3D image into 2D by an orthographic projection

Parallelepiped; front face with corners a, b, c, d , back face with corners e, f, g, h

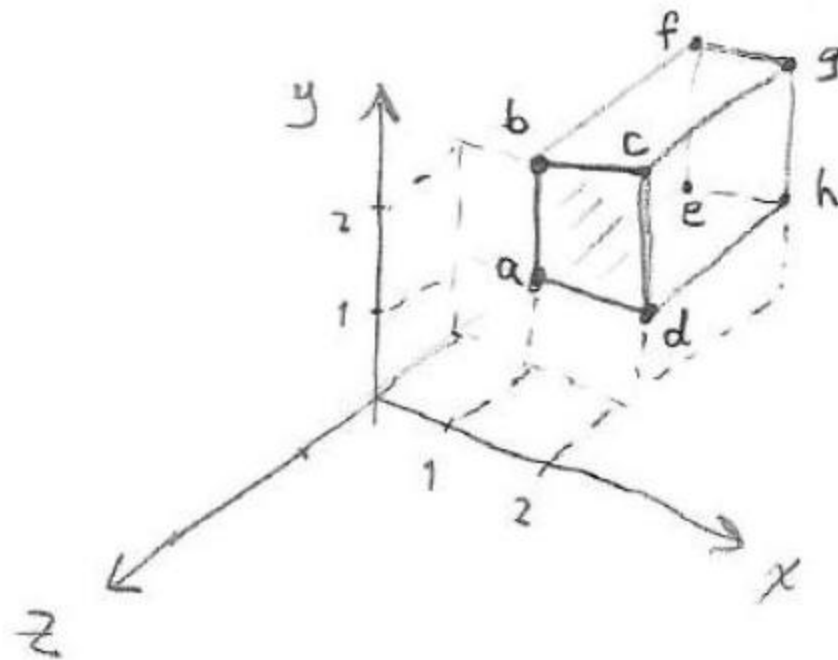

We put the coordinates into matrices to make it easier to express the calculations;

$$\begin{array}{l} \text{front face:} \\ \text{back face:} \end{array} \begin{bmatrix} 1 & 1 & 2 & 2 \\ 1 & 2 & 2 & 1 \\ -1 & -1 & -1 & -1 \\ 1 & 1 & 2 & 2 \\ 1 & 2 & 2 & 1 \\ -8 & -8 & -8 & -8 \end{bmatrix}$$

and all together as a set of homogeneous coordinates;

$$B = \begin{bmatrix} 1 & 1 & 2 & 2 & 1 & 1 & 2 & 2 \\ 1 & 2 & 2 & 1 & 1 & 2 & 2 & 1 \\ -1 & -1 & -1 & -1 & -8 & -8 & -8 & -8 \\ 1 & 1 & 1 & 1 & 1 & 1 & 1 & 1 \end{bmatrix}$$

A one point perspective transformation

$$M = \begin{bmatrix} 1 & 0 & 0 & 0 \\ 0 & 1 & 0 & 0 \\ 0 & 0 & 1 & 0 \\ 0 & 0 & -\frac{1}{4} & 1 \end{bmatrix}$$

(Remember, this would be M^T in the text.)

Apply this transformation to the corners of the parallelepiped;

$$MB = \begin{bmatrix} 1 & 1 & 2 & 2 & 1 & 1 & 2 & 2 \\ 1 & 2 & 2 & 1 & 1 & 2 & 2 & 1 \\ -1 & -1 & -1 & -1 & -8 & -8 & -8 & -8 \\ 5/4 & 5/4 & 5/4 & 5/4 & 3 & 3 & 3 & 3 \end{bmatrix}$$

Converting to physical space;

$$\begin{bmatrix} 4/5 & 4/5 & 8/5 & 8/5 & 1/3 & 1/3 & 2/3 & 2/3 \\ 4/5 & 8/5 & 8/5 & 4/5 & 1/3 & 2/3 & 2/3 & 1/3 \\ -4/5 & -4/5 & -4/5 & -4/5 & -8/3 & -8/3 & -8/3 & -8/3 \\ 1 & 1 & 1 & 1 & 1 & 1 & 1 & 1 \end{bmatrix}$$

Note that the edges parallel to the z -axis appear to be converging to the origin;

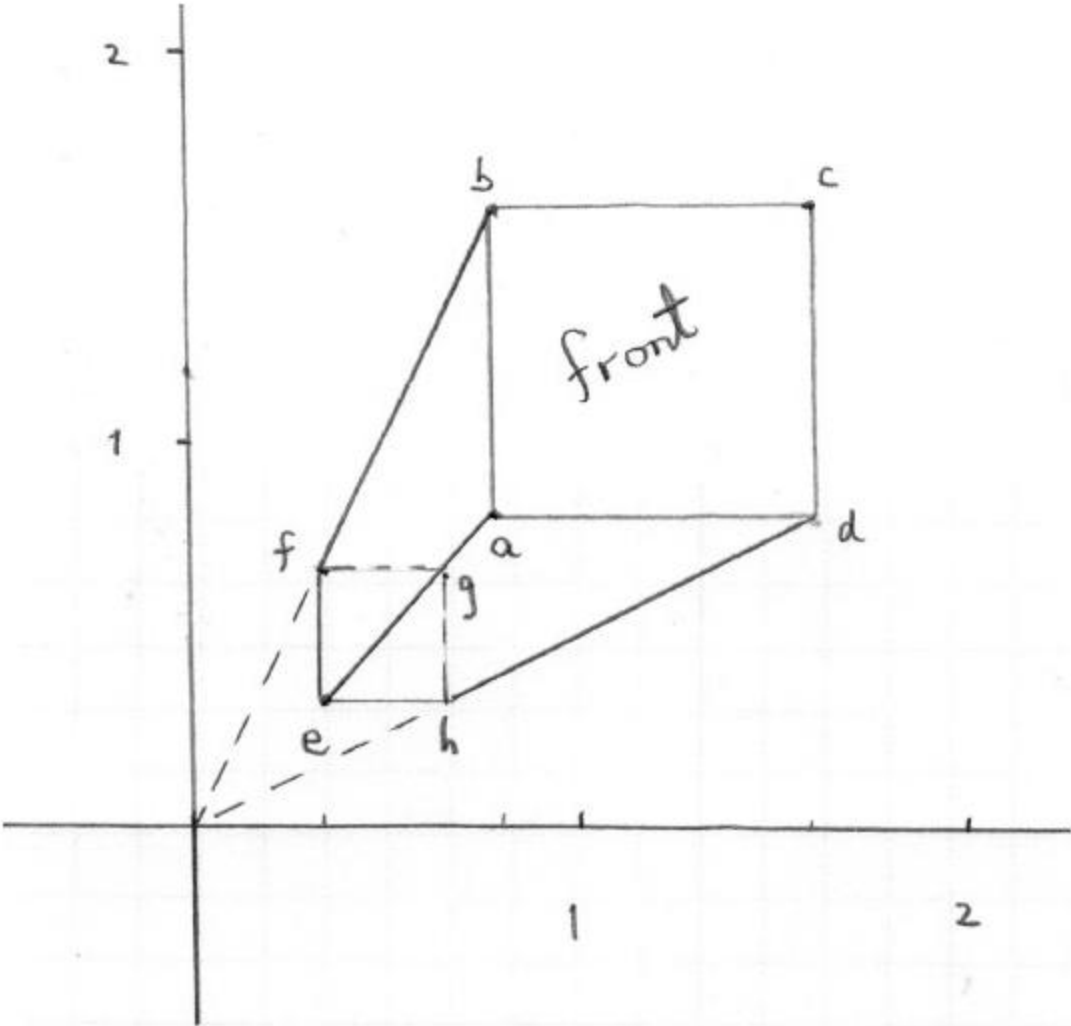

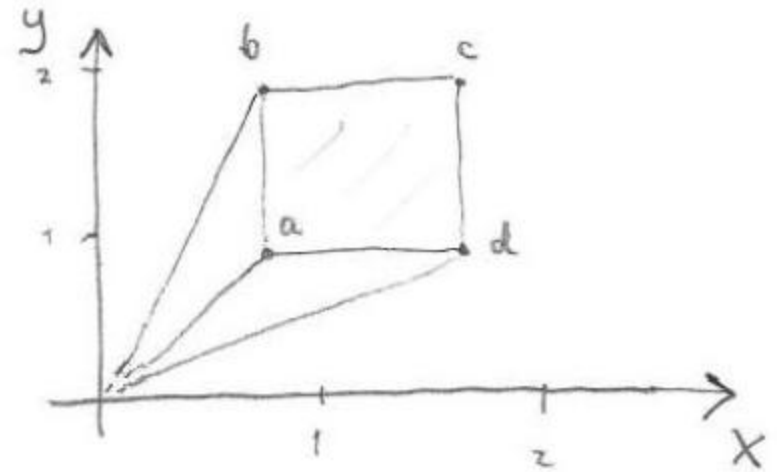
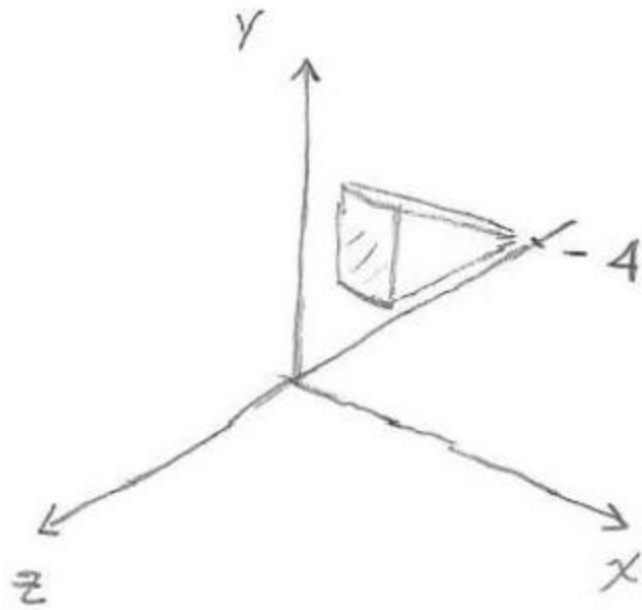

Note that the back face is being squeezed to the point located at $(0, 0, -4)$.

For example, we rotate around the y -axis by 30° first;

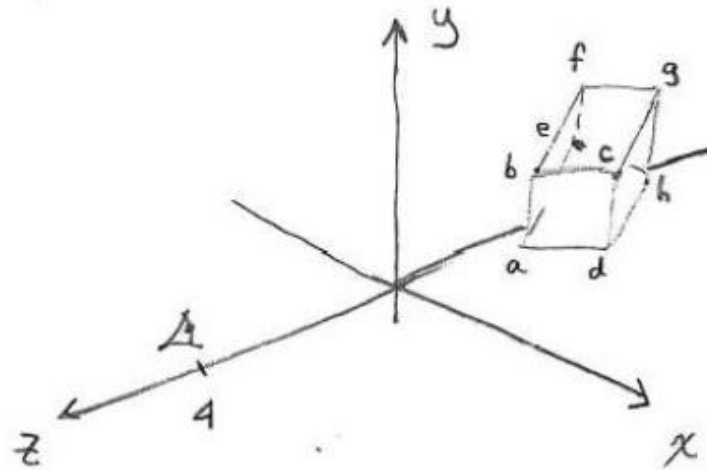

and then apply the one point perspective M above. The matrix T for this combined transformation is,

$$\begin{aligned}
 T = MR &= \begin{bmatrix} 1 & 0 & 0 & 0 \\ 0 & 1 & 0 & 0 \\ 0 & 0 & 1 & 0 \\ 0 & 0 & -\frac{1}{4} & 1 \end{bmatrix} \begin{bmatrix} \sqrt{3}/2 & 0 & 1/2 & 0 \\ 0 & 1 & 0 & 0 \\ -1/2 & 0 & \sqrt{3}/2 & 0 \\ 0 & 0 & 0 & 1 \end{bmatrix} \\
 &= \begin{bmatrix} \sqrt{3}/2 & 0 & 1/2 & 0 \\ 0 & 1 & 0 & 0 \\ -1/2 & 0 & \sqrt{3}/2 & 0 \\ 1/8 & 0 & -\sqrt{3}/8 & 1 \end{bmatrix}
 \end{aligned}$$

Now apply this transformation to the parallelepiped;

$$TB = \begin{bmatrix} 0.36 & 0.36 & 1.23 & 1.23 & -3.13 & -3.13 & -2.26 & -2.26 \\ 1 & 2 & 2 & 1 & 1 & 2 & 2 & 1 \\ -1.36 & -1.36 & -1.86 & -1.86 & -7.42 & -7.42 & -7.92 & -7.92 \\ 1.34 & 1.34 & 1.46 & 1.46 & 2.85 & 2.85 & 2.98 & 2.98 \end{bmatrix}$$
$$\rightarrow \begin{bmatrix} 0.27 & 0.27 & 0.83 & 0.83 & -1.1 & -1.1 & -0.76 & -0.76 \\ 0.74 & 1.48 & 10.36 & .068 & 0.35 & 0.7 & 0.67 & 0.33 \\ * & * & * & * & * & * & * & * \\ 1 & 1 & 1 & 1 & 1 & 1 & 1 & 1 \end{bmatrix}$$

Orthographically projecting this to the xy -plane gives;

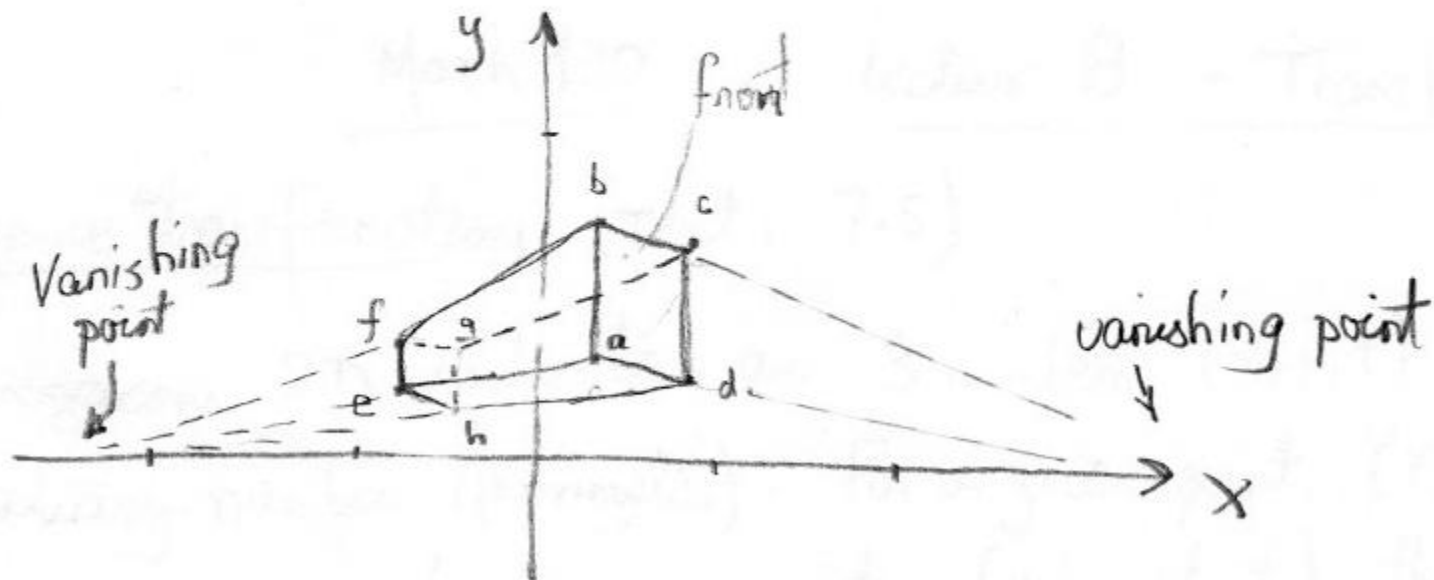

Sources for the development of (new) mathematics in the
17th Century; Science and Painting

Physics → Calculus

Painting → Projective geometry

Calculus: Newton, Leibniz, Maclaurin, ...:

Orbits of planets, mechanics, geometry of curves, ...

(see www.sfu.ca/~rpyke/fluxions.pdf)

11. Let us suppose that a straight line TMS touches a given curve at a point M (*i.e.* it does not cut the curve); and let the tangent meet AZ in T, and through M let PMG be drawn parallel to AY. I may say that the velocity of the descending point, describing the curve by its motion, which it has at the point

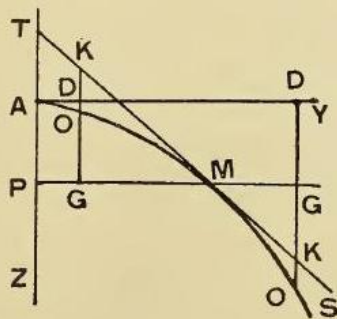
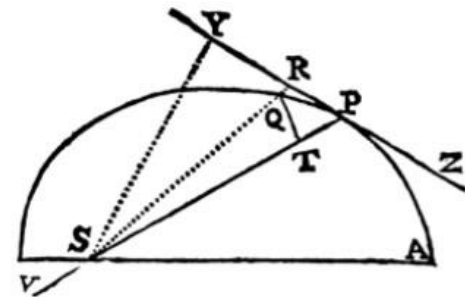

Fig. 20.

itta directe & tempus bis inverse. Q.E.D.
 etiam per Corol. 4 Lem. x.

endo
 neam
 recta
 into
 balio
 gatur
 la, ac
 ularis
 idum



do folidi illius ea semper fumatur quan-

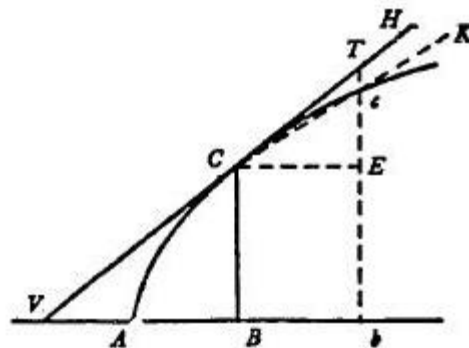

Perspective drawing: The beginning of projective geometry

A mathematical question: Two observers, O and O' create projections S and S' of an object onto planes P and P' .

What is the relation between S and S' ?

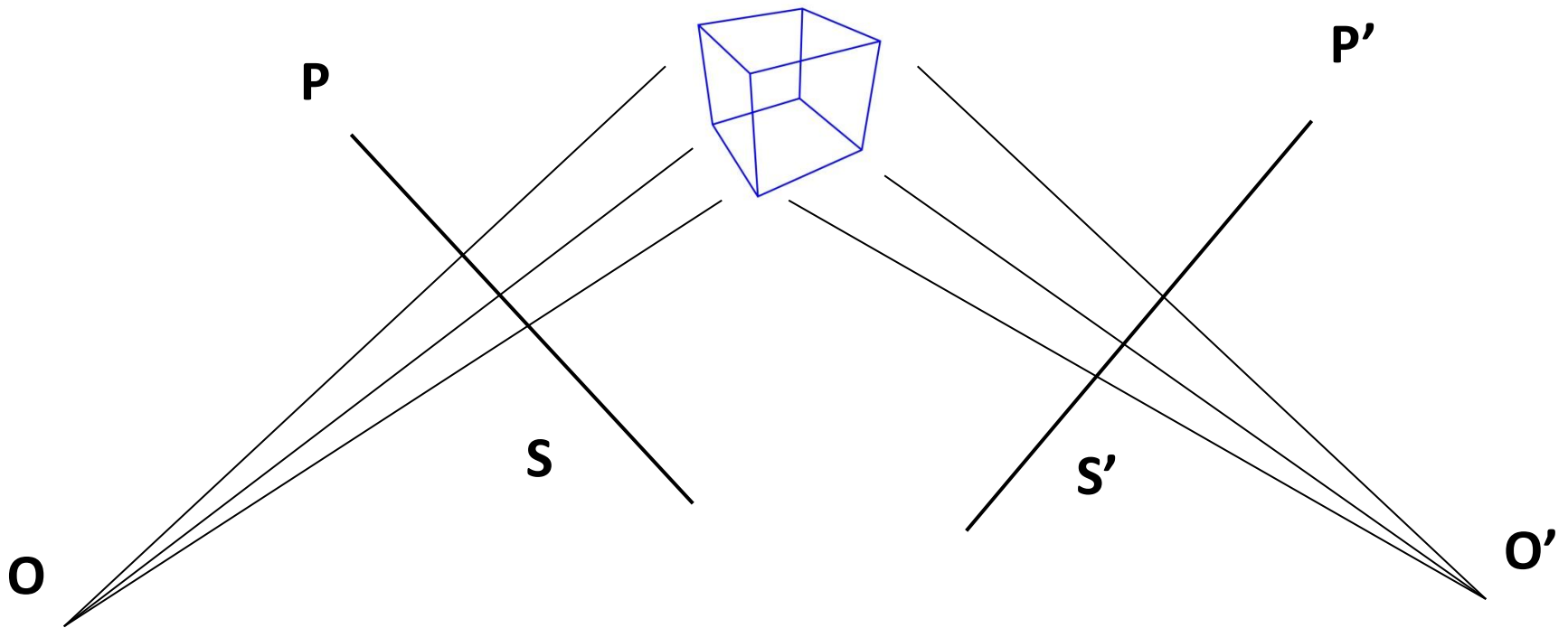

Projective geometry; 16th – 19th Centuries

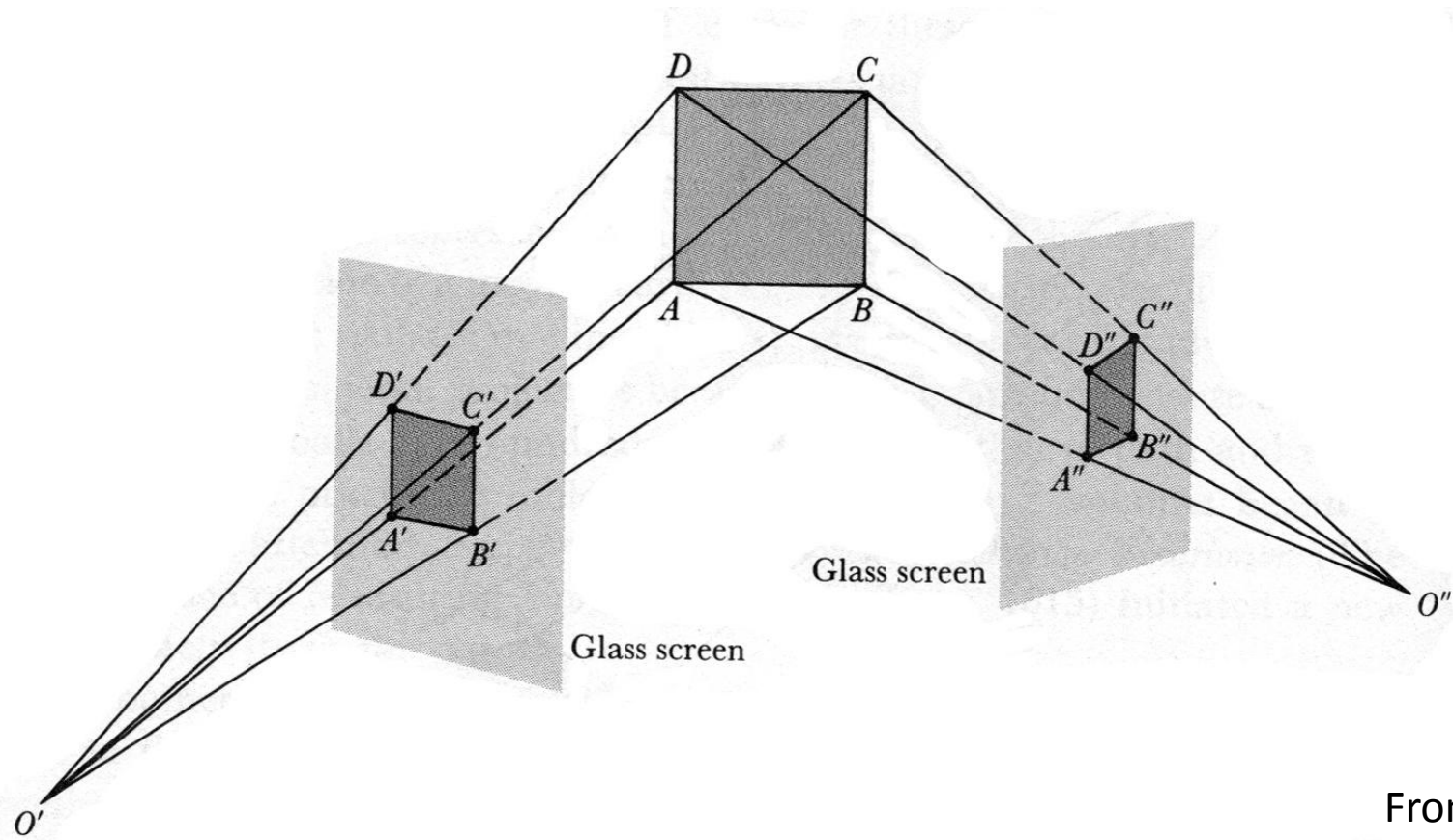

From: Kline

Projective geometry

Desargue's Theorem (~1650)

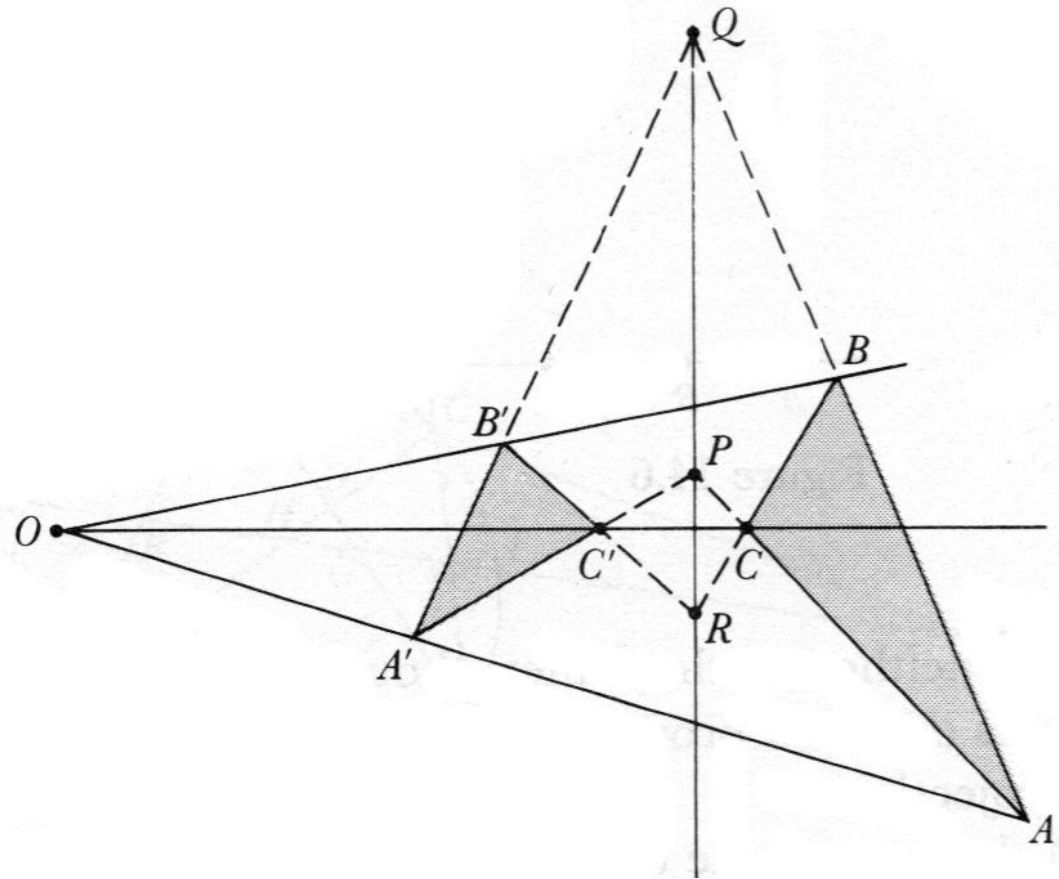

From: Kline

Some applications of projective geometry;

- Aerial photography
- Cartography/ Mapping

Some applications of projective geometry

Aerial photography

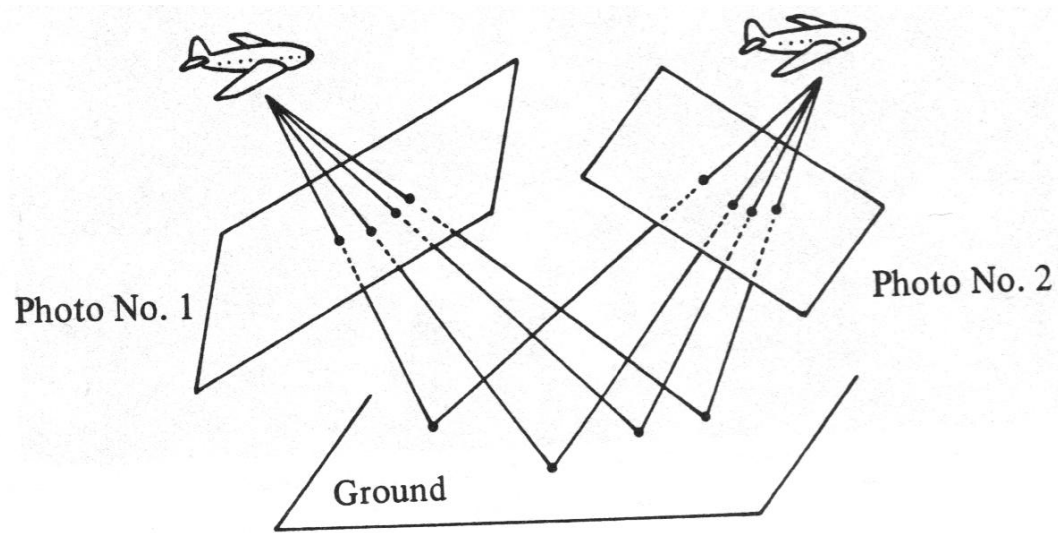

Figure 4.7.3

Image from: Berger

Some applications of projective geometry

Cartography

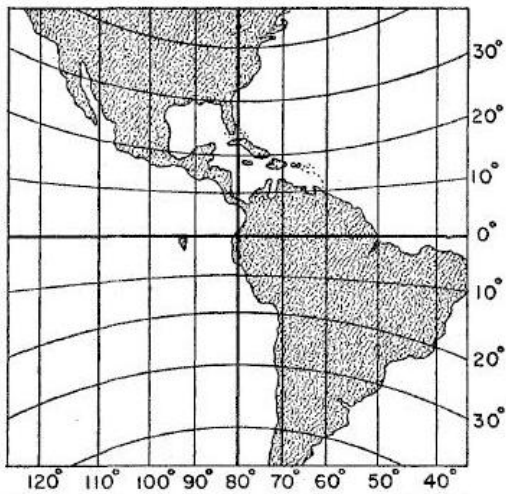

Figure 30. Gnomonic map of the Western Hemisphere

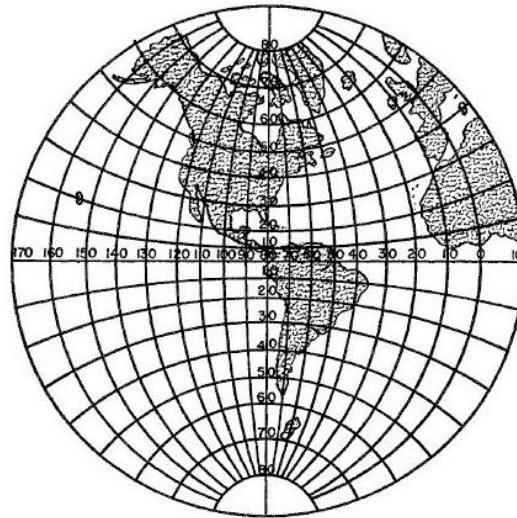

Figure 32. Stereographic map of the Western Hemisphere

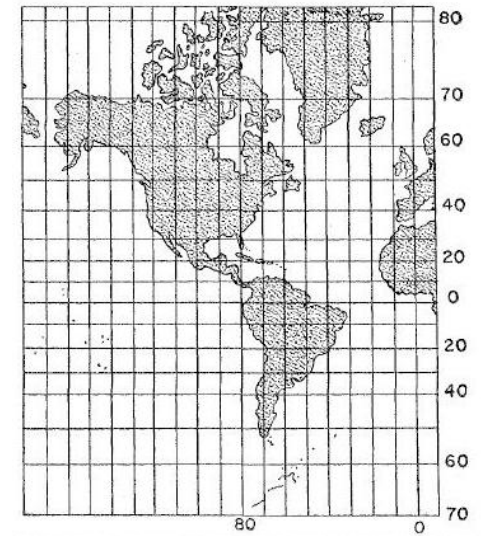

Figure 34. Mercator projection of the Western Hemisphere

Image from: Kline

Playing with perspective.....



*Whoever makes a DESIGN, without the Knowledge of PERSPECTIVE
will be liable to such Absurdities as are shown in this Frontispiece.*

William Hogarth, 1753

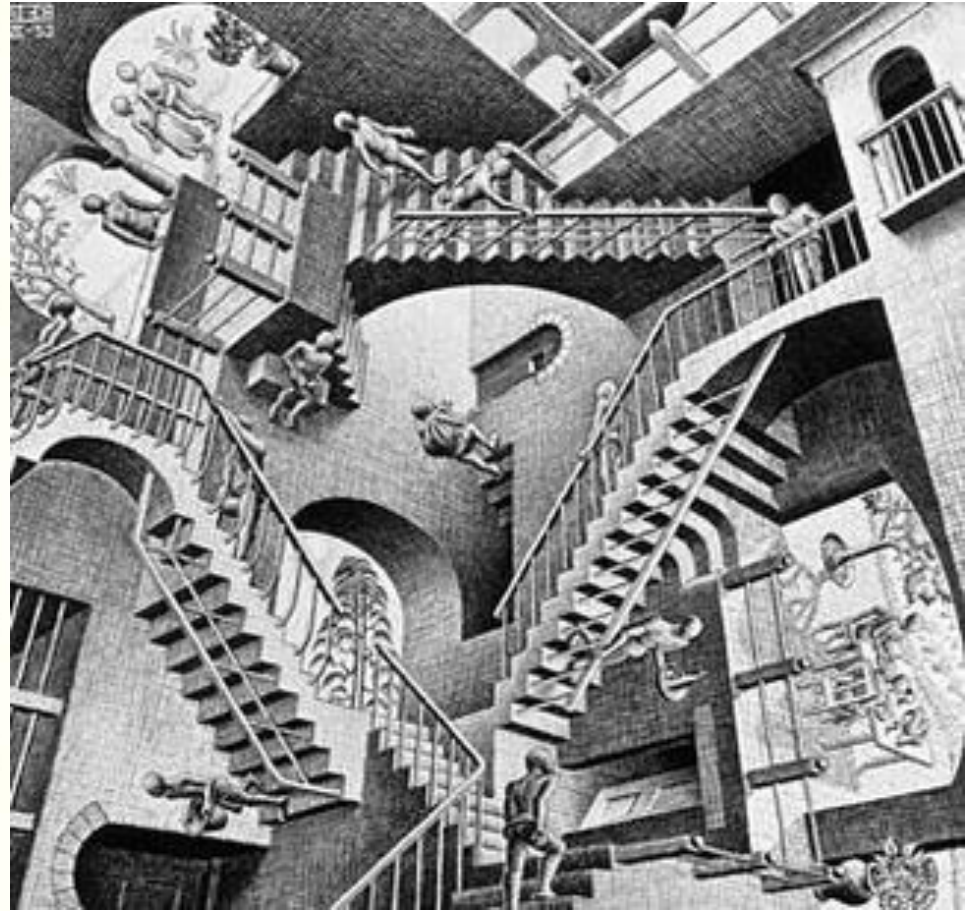

M.C. Escher, 1953

A nonlinear perspective; *Anamorphosis*

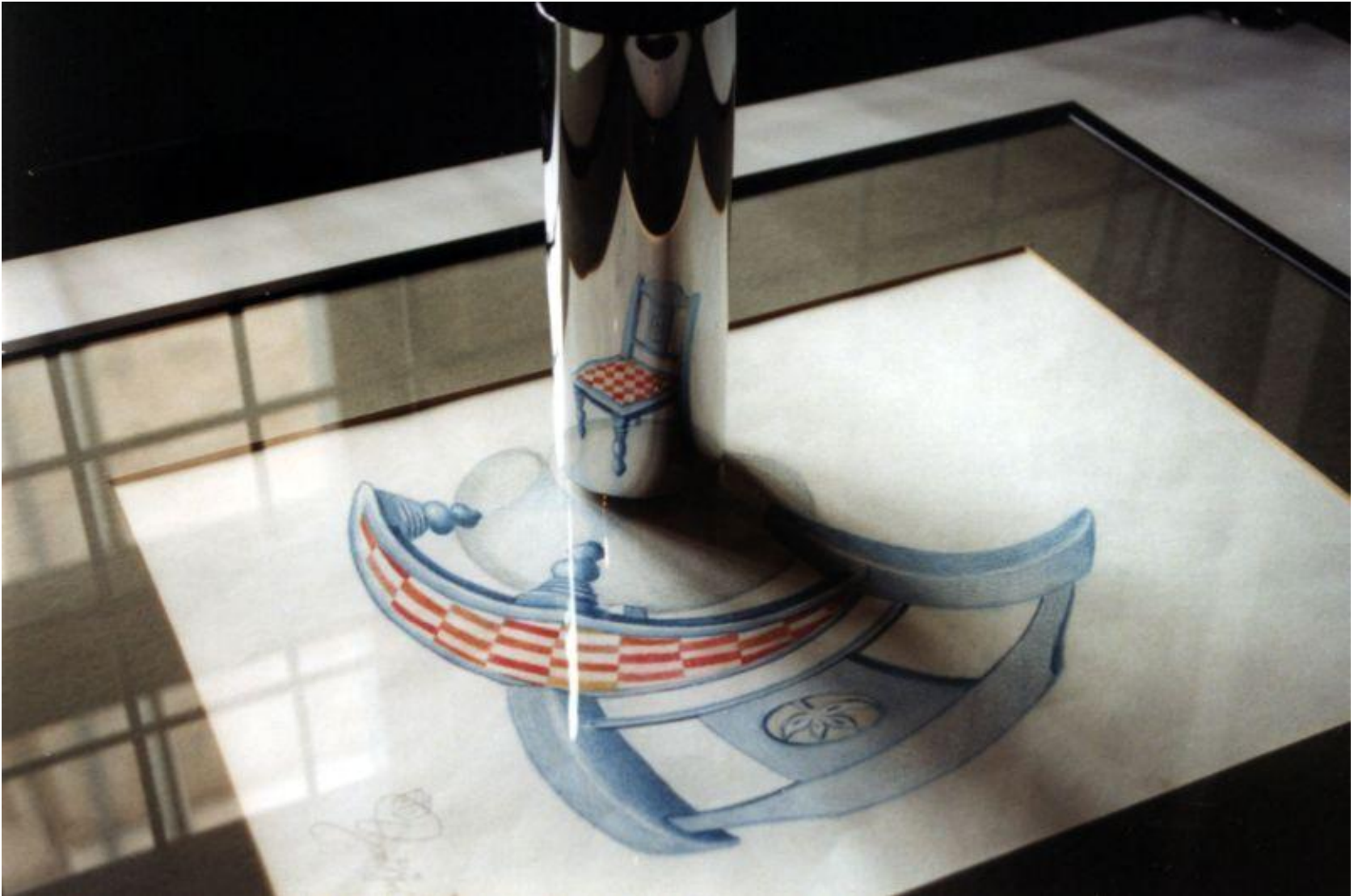

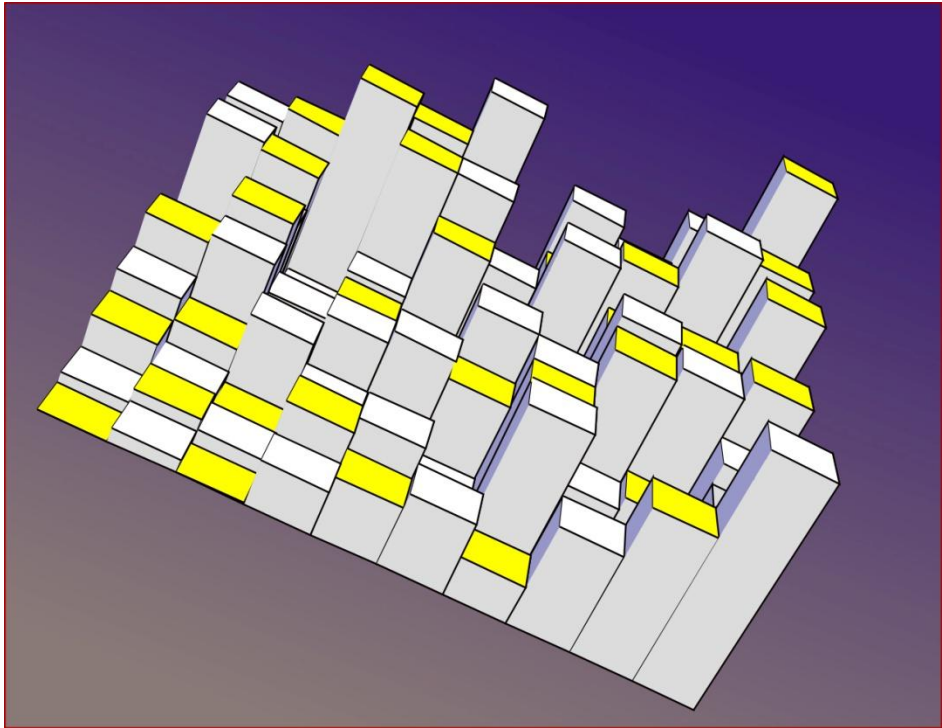

References:

Morris Kline, *Mathematics in Western Culture* (Chapters 10, 11). Available online through the SFU library.

Marcel Berger, *Geometry I* (Chapter 4).

Joseph D'Amelio, *Perspective Drawing Handbook*. Dover publications.

Ernest R. Norling, *Perspective Made Easy*.

David F. Rogers, J. Alan Adams, *Mathematical Elements for Computer Graphics* (Chapters 2,3).