

## On the Argument Structure of Primary Complements

Nancy Hedberg and Richard C. DeArmond

In this paper we will examine the internal structure of primary complements of the verb in more detail than has been done previously. We will propose that there are two basic levels for primary arguments: the head-argument level (level one) and the vector level (level two). The theme is assigned to the head-argument level as a default, and other primary argument theta roles to the vector level. In English, the head-complement is assigned Case by the verb, and the vector complements by a preposition which is inherent. Additionally there is a third level; this level is for displaced arguments.

Primary complements should be distinguished from secondary complements and adjuncts (DeArmond and Hedberg 1998). Primary complements fail the “pseudocleft test” since they cannot occur in the ‘post-do’ position in a VP pseudocleft, unlike secondary complements and adjuncts:

- (1) a. \*What John did to the church was walk.
- b. What Sue did with the key was open the door.
- c. What Jim did on Sunday was work.

Adjuncts can be distinguished from primary and secondary complements with regard to the “preposition stranding” test since the preposition introducing them cannot be stranded in *wh*-movement constructions, unlike the preposition of primary and secondary complements:

- (2) a. What did John walk to?
- b. What did Sue open the door with?
- c. \*What did Jim work on? [with temporal reading]

Configurational differences between the three levels of complements and adjuncts have been investigated in previous work, with the necessity for binary branching being argued for (DeArmond & Hedberg 2000). Here we examine in

detail the configurational structure of primary complements and the linking of two syntactic levels of primary complements to theta roles.

First we note that the default theta role for the head-complement is a theme, as in the sentences in (3):

- (3) a. Mary put the sugar on the table.  
 b. Bill pushed his car over the cliff.

The verb and the head-complement NP form a V1 phrase in the syntax. The head-complement forms level one as shown in figure (5) below, which represents a stative event such as that expressed in (4):

(4) The book is blue.

(5) [+St, -L] => 

$V^0$ , Theme
---------------

 = First Level (direct object)

Verbs and adjectives that only take a theme argument follow the format of (5). We should point out that we are adopting here a version of the subject internal hypothesis. In this version the subject may be derived by raising the theme to the subject position, or by raising the agent to the subject position, or some other argument when there is no agent. In (5) the features of the verb or adjective are [+St] (State) and [-L] (locative).

There are locative stative predicates:

(6) The book is on the table.

The second level contains the locative argument. Here, there are no vectors denoting direction:

(7) 

[+St]	<	[+L]	=>	$V^1$ , Location	= 2nd level
		[-L]	=>	$V^0$ , Theme	= 1st level

Second-level arguments are marked by prepositions in English. We put the question of indirect objects aside. Here, the locative preposition is *on*.

In the syntax first level arguments are assigned to the direct object. Second-level arguments are assigned to  $V^1$  complement positions in the syntax forming a PP. Such arguments always follow the direct object in the syntax.

Many verbs contain second level arguments which we will call vector arguments here. The first class of verbs are verbs denoting location. The vector-level contains PP complements of  $V^1$ . The complement can be a source, path, goal, or any combination of the three:

- (8) a. The dog walked away from the fence.
- b. Several deer ran from the hunter through the woods to the creek.
- c. The farmer loaded the hay onto the truck

Similar to our distinction between level-one (theme) arguments and level-two (locative and vector) arguments, Emonds 1991 distinguishes figure (theme) arguments from ground (source, path, goal) arguments. Furthermore, Tenny 1995 argues that theme arguments ("moved objects") are thematically licensed, whereas path and goal arguments are aspectually licensed.

The vector arguments are also second level arguments. The vector arguments are not ordered within the second level, but they must follow the first-level argument, the direct object:

- (9) a. The wolf chased several deer from the hill through the woods to the creek.
- b. The wolf chased several deer through the woods to the creek from the hill.
- c. The wolf chased several deer to the creek from the hill through the woods.

There are six possible orderings of the secondary arguments of which three are shown in (9). Because of this ordering and the binary branching hypothesis, we

label the dominant nodes as V<sub>j</sub><sup>2a</sup>, V<sub>j</sub><sup>2b</sup>, V<sub>j</sub><sup>2c</sup>, in ascending order. For example, (9b) has the following phrase structure:

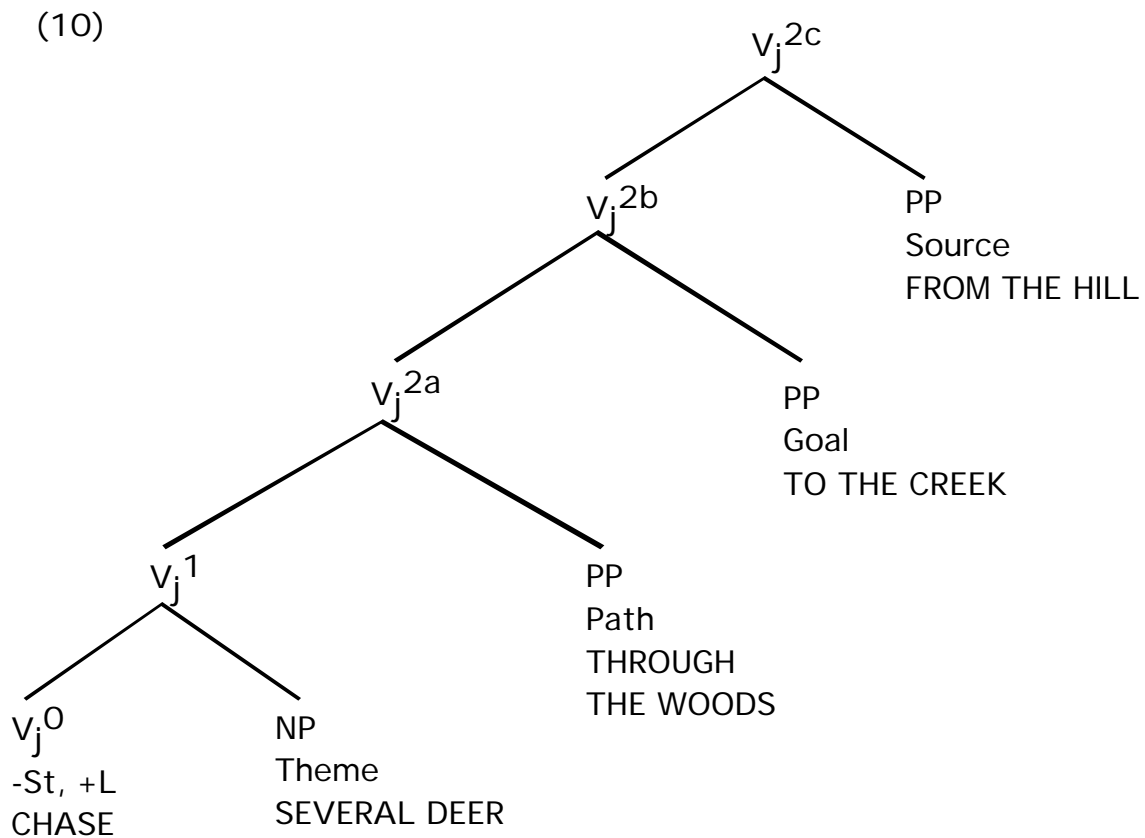

Both locative and vector argument may occur in level 2:

(11) Olive pushed the carriage into the front room.

The preposition in marks the location of the carriage after it had been pushed:

(12) The carriage is in the front room.

The preposition to marks the goal of pushing; it does not mark location:

- (13) a. \*The carriage is to the front room.  
 b. The carriage was pushed to the front room.

(13b) does not imply that the carriage was pushed into the front room. It could be at the entrance of the front room. First we recognize two sublevels within level 2:

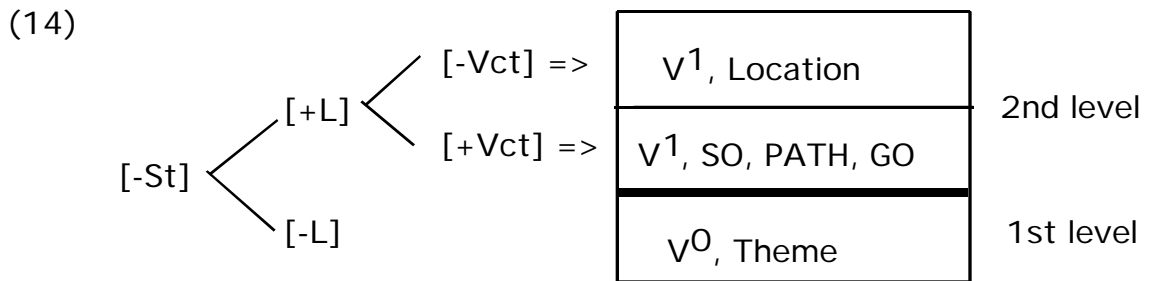

English restricts the locative prepositions to in and on combined with the goal in mixed construction of the type in (11). They are usually written as the compound prepositions into, onto. Other examples are usually written separately:

- (15) a. The mouse crawled out from under the cupboard.  
 b. The bat flew slowly away from inside the belfry.  
 c. Some children walked up to the wishing well.

There is a third set of arguments here represented by out and away, Time won't permit us to cover this third set of vector arguments here.

There is an apparent hierarchy: locative, vector 1 (to, from), vector 2 (out, away). The phrase structure for (11) is given below in (16):

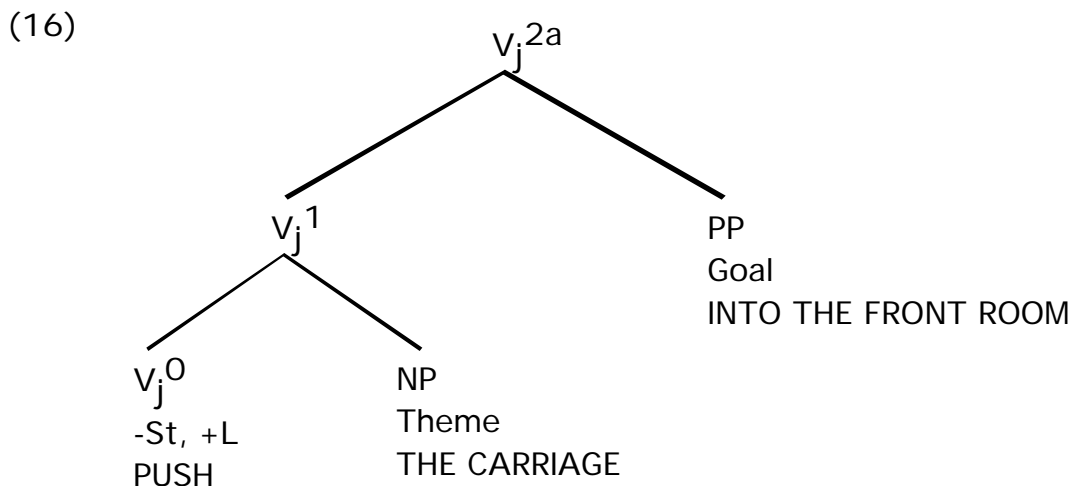

The above examples are all part of the default settings for level 1 and level 2 arguments. It is also possible for one of the level 2 arguments to occur as the

direct object (level 1). In example 16 the goal is the direct object. The theme is not expressed as a syntactic argument:

(17) The burglar entered the office of the local bank.

Semantically, the burglar is a theme; in the syntax we assume that there is no theta role theme.<sup>1</sup> Examples of this type are not transformationally derived, but are directly generated:

(18) [+St, -L] => V<sup>0</sup>, Locative = First Level (direct object)

The argument for claiming that (18) cannot be derived from a structure containing a second level complement such as (7) is that in some lexical items such as those in (19) do not allow the goal or any other argument to occur in the direct object position:

- (19) a. John walked to the store.  
b. \*John walked the store.

while others such as enter not only permit it, but require it as in (20):<sup>2</sup>

- (20) a. The burglar entered the office of the local bank through the window.  
b. \*The burglar entered into the office of the local bank through the window.

Sentence (4c) has the well known similar sentence with a different argument structure:

(21) The farmer loaded the truck with the hay.

---

<sup>1</sup> Jackendoff (1990) assumes that *burglar* is both agent and theme. We agree that this is the case for semantic roles, but not for theta roles.

<sup>2</sup> There is a related lexical item *enter* which takes both a theme and goal:  
i. The Jones's entered their child into Kindergarten.

Interesting here is that the goal is now the head-complement, and the theme occurs in the vector level although it is not a vector theta role. It is still a primary complement. The theme cannot be assigned to level 2 since, if the theory is correct, only locative and vector arguments can be assigned there. We propose that there is a third level, which is not directly tied to a semantic role, unlike the first and second levels. The function of this level is to hold chomeurs. The preposition *with* has no semantic value. It is inserted as a dummy preposition to assign Case to the chomeur in English. The chomeur is not a secondary complement since the chomeur cannot occur in the post-do position like a secondary complement can (DeArmond and Hedberg 1998):

(22) \*What the farmer did with the hay was load the truck.

The intuition here is a subtle one. There is a grammatical reading of sentence (18), but it is one in which the hay is an instrument instead of a theme, a questionable reading. In our understanding of this reading of sentence (22), the hay does not actually get loaded onto the truck. The lack of a theme reading is clearer when the definite article is removed, in which case the sentence becomes more clearly ungrammatical:

(23) \*What the farmer did with hay was load the truck.

The preposition *with* in (21) is a dummy preposition assigning Case to the hay. It corresponds to a chomeur in Relational Grammar (Perlmutter and Postal 1983). Note that there is another construction which uses the main verb *do*:

(24) What the farmer did with the hay was load it onto the truck.

The theme argument with this use of *do* is always a chomeur marked with *with* and serves as a useful test for differentiating the semantic roles theme and patient.

- (25) a. Milly broke the dish.  
 b. \*What Milly did with the dish was break it.  
 c. What Milly did to the dish was break it.

The dish is semantically the patient in (25); it undergoes a change of state.

Let us return to (8c). The sentence may occur with a goal argument:

- (26) The farmer loaded the hay from the dock onto the truck.

When the goal is in the direct object position (level 1), the source is not possible:

- (27) \*The farmer loaded the truck from the dock with the hay.

The PP from the dock could be modifying truck, but it cannot refer to the source location of the hay. This is one of the arguments that (21) cannot be derived syntactically from (8c) because the argument structure changes where one argument is possible in one construction but not possible in the other.

There is another construction containing a chomeur, but with a different dummy preposition:

- (28) a. The bandit robbed the tourist of his money.  
 b. Mary was deprived of her innocence.  
 c. Our maid swept the floor clean of dust.  
 d. The doctor cured Pat of pneumonia. (= Levin's (135b))

In (28) money, innocence, dust, and pneumonia are themes and they do not occur in the direct object position. The preceding NP does. Note that the direct object NPs here are each a source. In the earlier types, the direct object is a goal.

We present the dummy preposition rule in (29):

- (29) **Dummy Preposition Rule**  
 For the purpose of assigning Case to a chomeur, insert the dummy preposition with if the preceding level-one argument



is a goal, or insert the dummy preposition of if the preceding level-one argument is a source.

Next consider verbs that include experiencers:

- (30) a. John likes Mary.  
b. John is fond of Mary.  
c. Mary appeals to John.

The default position of the apparent theme Mary seems to be the head-complement. However, it is not clear that Mary is actually the theme. Following an idea by Gruber (1965), it can be argued that Mary is the source of John's affection, and that John is the goal--this claim is supported in (30c) where to occurs overtly marking the goal. The preposition of here supports the hypothesis that Mary is a source. What is the theme? Semantically it is the concept of liking or affection. The theme is incorporated into the lexical entry of the verb, and is not present syntactically. John is semantically an experiencer, but we consider semantic experiencers to be goal arguments syntactically.

Normally, level-two arguments cannot occur as the subject of the sentence--they are marked with preposition. We suggest that in (30a) and (30b) the goal is assigned to the level-one argument, which is then raised to the subject position in the syntax. In (30c) the source is assigned to the direct object position and is raised to the subject position in the syntax.

(31)

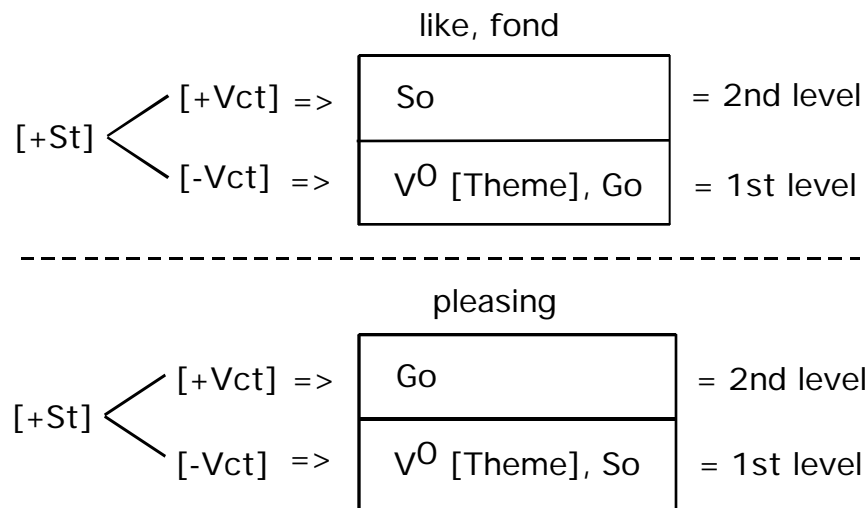

These and other examples show the pattern for first- and second-level primary arguments. When the theme is an argument, it is a first level argument--the head-complement. The default theta roles for the second level are those associated with source, path, and goal. At least three types of verb classes exist: verbs of motion, verbs of change, and verbs denoting an abstract sense of motion: liking, seeing, possession, knowing, and so forth.

Another class of verbs includes those mentioned by Levin (1993: 53):

- (32) a. Helen wiped the fingerprints off the wall.  
b. Helen wiped the wall. (= Levin's (137))

In (32a) the fingerprints is the theme and off the wall is the source. In (32b) the theme is missing and the source is promoted to the direct object position. however, this does not appear to be a fourth class as the theme may occur as a chomeur marked with of:

- (33) Helen wiped the wall of the fingerprints.

There are problems that remain unexplained at this time. Levin (1993: 79) mentions time-subject alternating verbs:

- (34) a. The world saw the beginning of a new era in 1492.  
b. 1492 saw the beginning of a new era. (= Levin's (273)).

In (34a) *the world* is a semantic goal, *the beginning of a new era* is the semantic source and the syntactic direct object, and *1492* is a time argument (it is probably a theme in a time level). In (34b) there is no theme and the source remains in the direct object position. What is the argument structure of *1492* here given the subject internal hypothesis? We leave this problem for further research—though it does suggest that the subject internal hypothesis may not be a syntactic phenomenon.

The patterns that we have observed in this paper are the following:

- (35) a. The default for the theme is the first level position (the direct object)  
b. The default position for location and the arguments of change is the second level.  
c. One of the second level arguments may move to the first level if the theme does not occupy that argument position.  
d. The theme may not move to a second level position, but it may move to a non-argument level.

It is important to stress here that we are not assuming that the arguments structures proposed above are determined in the syntax. They could be determined in the lexicon, or they could be determined in some component that by its nature would be very controversial, such as "presyntax", given that none of the theories developed by Chomsky in the last forty years recognizes presyntax. Presyntax could be a component where not only the rules for word formation occur, but also where the rules determining the argument structure of lexical items occur. Other kinds of rules which do not fit the standard ideas of syntax and phonology might also occur here, too. If this component exists. it should be very interesting. However, time and space preclude us from discussing this here.

## References

Chafe, Wallace.

DeArmond, Richard C. and Nancy Hedberg. 1998. "On Complements and Adjuncts." *In Proceedings of the 1998 Annual Conference of the Canadian Linguistics Association*, University of Ottawa: Cahiers Linguistiques d'Ottawa.

DeArmond, Richard C. and Nancy Hedberg. 2000. "The Configuration of Primary and Secondary Complements." *In Proceedings of the 2000 Annual Conference of the Canadian Linguistics Association*; University of Ottawa: Cahiers Linguistiques d'Ottawa.

Emonds, Joseph E. 1991. "Subcategorization and Syntax-Based Theta-Role Assignments." *Natural Language and Linguistic Theory*. 9. 369-429.

Gruber, Jeffrey. 1976. *Lexical Structure in Syntax and Semantics*. Amsterdam: North-Holland.

Jackendoff, Ray S. 1990. *Semantic Structures*. Cambridge, MA: MIT Press.

Levin, Beth. 1993. *English Verb Classes and Alternations: A Preliminary Investigation*. Chicago and London: The University of Chicago Press.

Perlmutter, David and Paul Postal. 1983. "Toward a Universal Characterization of Passivization." In David. M. Perlmutter, *Studies in Relational Grammar 1*. Chicago: The University of Chicago Press.

Tenny, Carol L. 1995. "Modularity in Thematic versus Aspectual Licensing: Paths and Moved Objects in Motion Verbs." *Canadian Journal of Linguistics*. 40. 201-234.

) e. ddfdfd