

LAB 6

Differential and Operational Amplifiers

Reading: Malvino, Chapter 18

First we will construct a differential amplifier and measure its properties. Many of the characteristics of the differential amplifier pertain to integrated circuit operational amplifiers. Next you will measure characteristics of the common 741C op amp and the better-performing LF411 or TL071 op amp which has a dual FET input circuit. (Note: In this experiment you may use either ± 12 V or ± 15 V for the op-amp power depending on your breadboard box. Certain values will have to be adjusted accordingly.)

1. The Differential Amplifier

a) Calculate the tail current of the circuit in Fig. 6.1 as well as the base currents in each transistor. The $22\ \Omega$ swamping resistors are used to improve the match between the discrete transistors. Use the h_{FE} values of your transistors or assume a value of 200 if you haven't kept them. Build the differential amplifier shown in Fig. 6.1 and compare the measured tail and base currents with the calculated values.

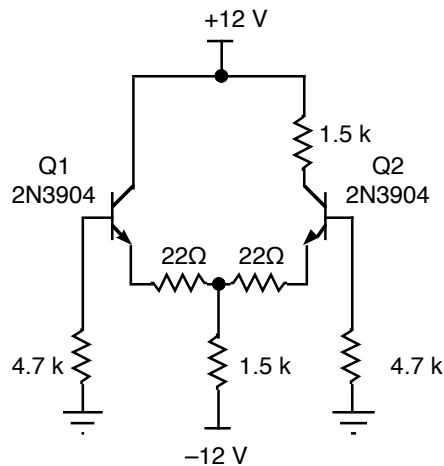

Fig 6.1

b) In Fig. 6.2(a), if you ground the base of transistor Q_1 , the transistors are identical and the components have the values shown, then the output voltage will be +6.35 V. For this

experiment, any deviation from +6.35 V will be called $V_{\text{out(off)}}$. Connect the circuit of Fig 6.2(a). Jumper the base of Q_1 to ground and measure $V_{\text{out(off)}}$. Take off the jumper and connect the potentiometer voltage-divider and adjust it until the output voltage is +6.35 V. Record the base voltage of Q_1 as $V_{\text{in(off)}}$.

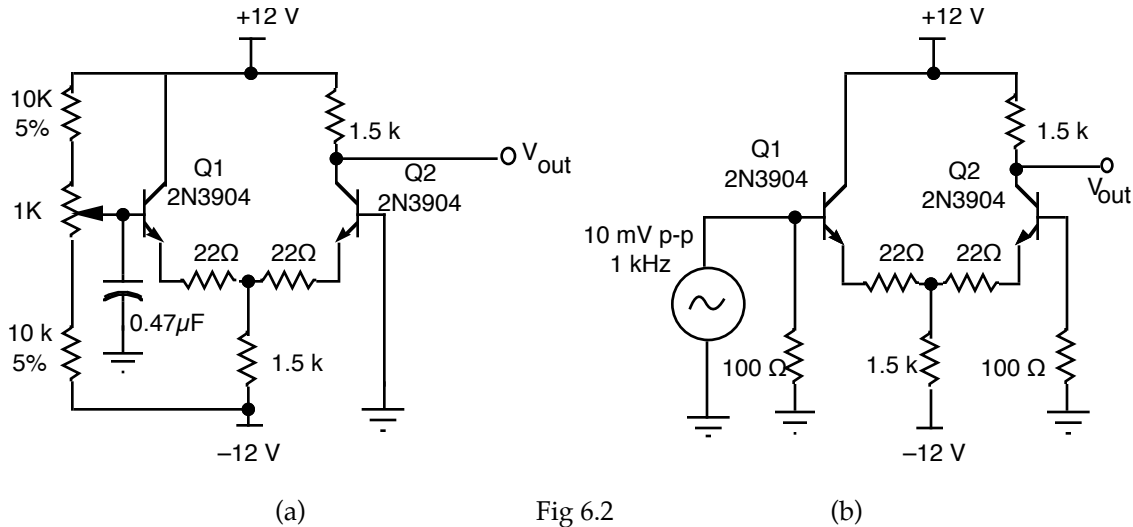

Fig 6.2

c) Calculate the expected values of the differential and common-mode gains and the Common Mode Rejection Ratio. Measure the differential and common-mode gains, A and A_{CM} , using the connection of Fig. 6.2(b). Use a frequency of 1 kHz and a signal level of around 10 mV p-p.

The HP function generators provide a minimum output amplitude of 50 mV. Use the 10 k potentiometer on the experiment board to make a voltage divider with a 10 mV output.

2. The Operational Amplifier

a) *Input offset and Bias Currents.* The 741C has a typical $I_{\text{in(bias)}}$ of 80 nA. Assuming that this is the current through each 220 k resistor in Fig. 6.3, calculate the dc voltages at both inputs. Now connect the circuit and measure the input voltages. Repeat this measurement for a FET input op amp such as LF411 or TL071. Calculate $I_{\text{in(off)}}$ and $I_{\text{in(bias)}}$ in both cases and compare the two op amps.

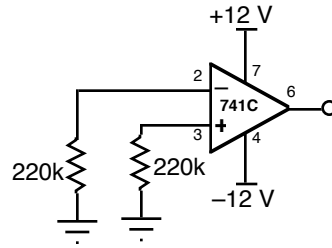

Fig 6.3

b) *Output Offset Voltage*. Connect the circuit of Fig. 6.4 using a 741C op amp.

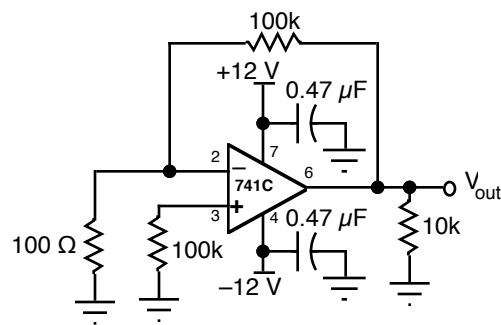

Fig. 6.4

The bypass capacitors are used on each supply voltage to prevent oscillations. This is discussed in Ch. 22 of Malvino, 5th ed. These capacitors should be connected as close to the IC as possible.

Measure the dc output voltage $V_{\text{out(off)}}$. From the closed-loop gain of the circuit as connected, A_{CL} , you can calculate the input offset voltage: $V_{\text{in(off)}} = V_{\text{out(off)}} / A_{\text{CL}}$. Also measure $V_{\text{out(off)}}$ and calculate $V_{\text{in(off)}}$ for a bifet op amp such as LF411 or TL071 in the same circuit.

c) *Maximum Output Current*. Disconnect the right end of the 100 k feedback resistor and connect it to +15 V. This will apply about 15 mV to the inverting input and saturate the op amp. Replace the 10 k load resistor by an ammeter and measure the maximum output current I_{max} . Do this for both the 741C and LF411 op amps.

d) *Maximum Peak-to-Peak (MPP)*. Measure the MPP values for both op amps by increasing the signal level at 1 kHz until you start to see clipping on either peak.

e) *Slew Rate*. (optional) Connect the circuit of Fig 6.5 choosing R_2 between 100 k Ω and 1 M Ω . Measure the slew rate of the 741C op amp and the FET input op amp.

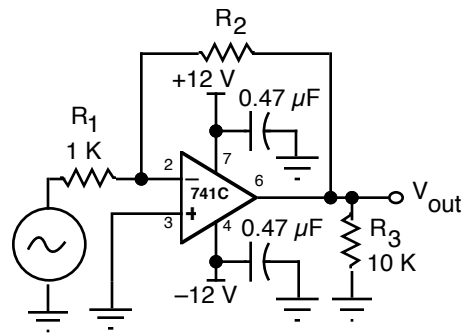

Fig 6.5

f) *Power Bandwidth*. (optional) Change R_2 to 10 k. Set the ac generator at 1 kHz. Adjust the signal level to get 20 V p-p output from the op amp. Increase the frequency from 1 to 20 kHz and find the approximate frequency where slew-rate distortion starts. Do for both a 741C and a FET input op amp.

Homework

1. Calculate the values for I_{tail} and the base currents of the differential amplifier. Use the currents to calculate $I_{in(bias)}$ and $I_{in(off)}$. Predict the differential gain, A , the common-mode gain, A_{CM} , and the CMRR of the differential amp. Express the CMRR in dB.
2. Calculate the input voltages of the op amp circuit in part 2(a).