

LAB 7

Operational Amplifiers II

Reading: Malvino, Chapters 19 and 20 and section 21-1
Hayes and Horowitz, Class 8, Lab 8 and Ch. 4 Worked examples on pp175, 176.

This week's experiment will use the ideal properties of operational amplifiers to build some commonly used practical circuits. [The diagrams in this lab don't explicitly show the power connections for the op amps. Refer to Lab 8 if you have forgotten the power pin numbers.]

1. Non-inverting Voltage Feedback

Design a non-inverting voltage amplifier with a closed-loop gain of 10. Use a FET input op amp and choose components with values closest to those specified in your design. Build the circuit and measure the gain. Calculate the theoretical input and output impedances, then measure the input and output impedances if they are within measurable ranges.

2. Inverting Voltage Feedback

Now design an op amp circuit with a closed-loop gain of -10 using inverting voltage feedback. Calculate input and output impedances. Build the circuit and repeat the measurements specified in part 1.

3. Current to Voltage Converter

The simplest current-to-voltage converter is just a resistor. An op amp in the circuit makes a much better device. The MRD-300 phototransistor can be hooked-up as either a photodiode (connect base and emitter leaving the collector unconnected) or as a phototransistor (base unconnected, emitter and collector connected). In either case it acts like a current source whose current depends on the amount of light that hits it.

a) Connect the MRD-300 as a photodiode and use a $10\text{ M}\Omega$ feedback resistor as in Fig 9.1. If the output voltage is too large, reduce the resistor to $1\text{ M}\Omega$. If you see fuzz on the output try a $0.001\text{ }\mu\text{F}$ capacitor across the feedback resistor. (How does this capacitor affect the feedback at high frequencies?) Connecting the output of the op amp to the scope, you should see the modulations from the lab's fluorescent lights. What is the photocurrent produced by the MRD-300? Cover the phototransistor with your hand to make sure it's the lights you are seeing. Look

at the summing junction, X, with the scope as V_{out} varies. Why is it better to use this op amp rather than just a $10\text{ M}\Omega$ resistor?

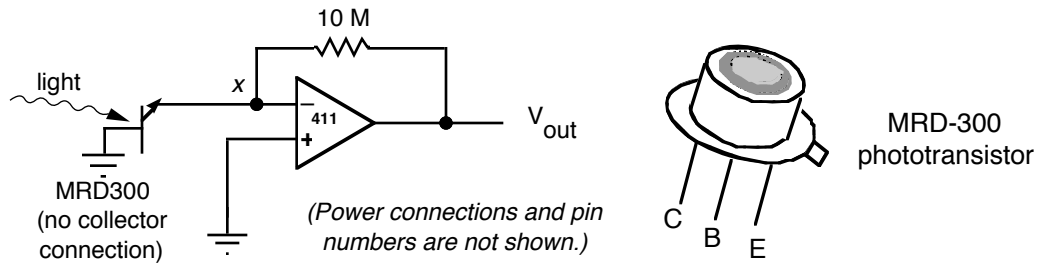

Fig. 9.1

b) [An analog oscilloscope must be used for this exercise to work.] Connect the MRD-300 as a phototransistor as shown in Fig 9.2. Now how much photocurrent is produced? Put the photodiode on the end of a twisted-pair wire so that you can put the diode up against the screen of the scope. This puts the scope in the feedback loop. Why is the diode so shy?

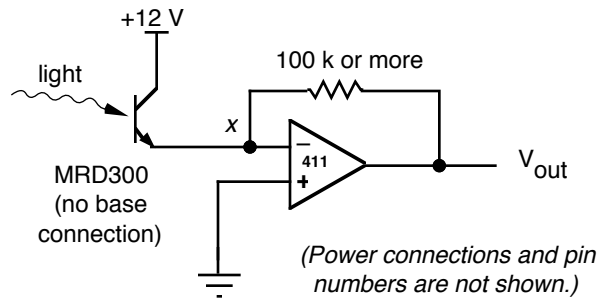

Fig. 9.2

4. The Active Rectifier

Build the active rectifier circuit shown in Fig. 9.3. Explain why it works better than the passive rectifier used in a previous lab.

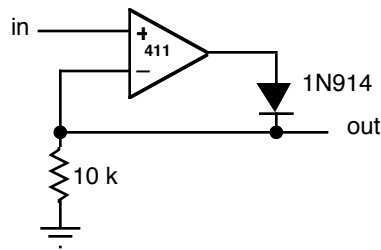

Fig. 9.3

4. Integrators and Differentiators

The following circuit acts like a differentiator at some frequencies, an integrator at others. Determine values of the resistors and capacitors so that the circuit will integrate one frequency range and differentiate in another range, both easily accessible by your function generator. Try it out. Verify its properties by finding what range of frequencies it differentiates and what range it integrates. Check it with square and triangle waves. Examine the phase relationship between v_{out} and v_{in} for a sine wave as a function of frequency.

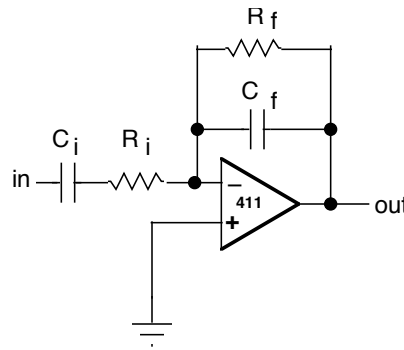

Fig. 9.4

Homework

1. Design the circuits and calculate the quantities needed for parts 1 and 2 of this lab.
2. Find values of capacitors and resistors for the combination integrator/differentiator circuit of part 4