

Mobile Application Part protocol implementation in OPNET

Vladimir Vukadinovic and Ljiljana Trajkovic

School of Engineering Science
Simon Fraser University
Vancouver, BC, Canada
E-mail: {vladimir, ljilja}@cs.sfu.ca

Abstract

This paper describes OPNET implementation of the Mobile Application Part (MAP) protocol within the General Packet Radio Service (GPRS) model. MAP represents an application layer protocol residing on top of the Signaling System 7 (SS7) protocol stack. In GPRS networks, MAP protocol supports signaling exchanges with Home Location Register (HLR) and Equipment Identity Register (EIR). We begin with a brief introduction to SS7 protocol stack and GPRS architecture. We then describe MAP features related to GPRS and modifications that we implemented in the GPRS OPNET model to provide signaling capabilities for communication between HLR and the Serving GPRS Support Node (SGSN). We provide implementation details and evaluate the impact of the MAP protocol overhead on network response time.

Keywords: Wireless networks, General Packet Radio Service (GPRS), Signaling System 7 (SS7), MAP protocol.

1. Introduction to SS7

Common Channel Signaling System 7 (SS7) is an out-of-band signaling system for Public Switched Telephone Networks (PSTNs) and Public Land Mobile Networks (PLMNs). It defines procedures for connection setup, management, and tear down, as well as protocols used by network elements to exchange billing and routing information. It is also used for wireless services, such as personal communications services (PCS), wireless roaming, and mobile subscriber authentication. SS7 messages are transferred via a logically separate digital network that exists within a telecommunication network that carries voice or data traffic [1]. SS7 is a standard defined by the International Telecommunication Union - Telecommunication Standardization Sector (ITU-T). National variants are permitted, such as American National Standards Institute (ANSI) and Bellcore standards used in North America, and European Telecommunications Standards Institute (ETSI) standard used in Europe.

Three distinct components (nodes), can be identified in an SS7 network: Service Switching Points (SSPs), Signal Transfer Points (STPs), and Service Control Points (SCPs). Architecture of an SS7 network is shown in Figure 1. Service Switching Points (SSPs) are voice switches with the SS7 protocol stack, interconnected by signaling links. SSPs create call-related signaling messages and send them to other SSPs or query remote shared databases in SCPs to find out how to route calls. SSPs originate, terminate, or switch calls. Signal Transfer Points (STPs) are packet switches, but they act as routers for signaling messages. They relay SS7 messages between SSPs and remote databases. STPs usually do not originate signaling messages. Signal Control Points (SCPs) are front ends for application-specific databases. SCPs accept queries from SSPs and return

requested information from databases. Typical examples of such application-specific databases are Home Location Register (HLR), Visitors Location Register (VLR), and Equipment Identity Register (EIR). These databases are standard elements of Global System for Mobile communication (GSM) and General Packet Radio Service (GPRS) networks.

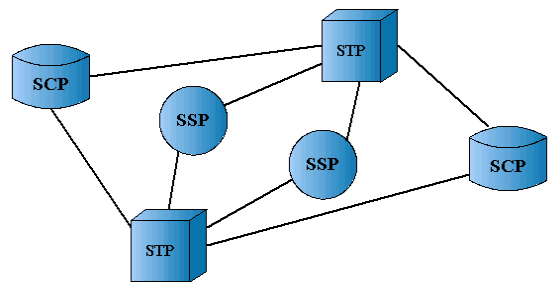

Figure 1: SS7 network elements.

The SS7 protocol stack consists of four levels (layers). The three lowest levels are combined into one set of protocols, called the Message Transfer Part (MTP). The MTP is split into levels 1 through 3, corresponding to the lowest three levels in the OSI seven-layer protocol stack. Level 4 consists of several protocols (called user parts and application parts), such as Signaling Connection Control Part (SCCP), Telephone User Part (TUP), ISDN User Part (ISUP), Intelligent Network Application Protocol (INAP), and EIA/TIA interim standard 41 (IS41) as shown in Figure 2.

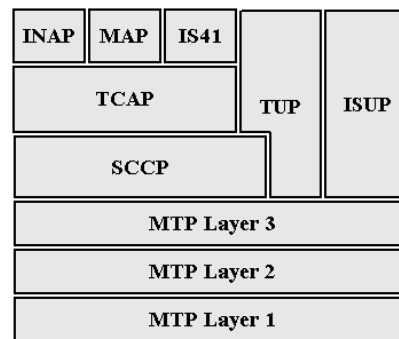

Figure 2: SS7 protocol stack.

The Mobile Application Part (MAP) resides on top of the SS7 protocol stack. It provides procedures for location management, subscriber data management, authentication, call handling, subscriber tracing, and short message service (SMS) management. Its important role is to handle mobility procedures used to pass mobile subscriber's information from one switching area to another. These procedures involve signaling exchanges with databases. When a mobile subscriber roams into a new switching area, its subscription profile is retrieved from the

subscriber's Home Location Register (HLR) using MAP information carried within Transaction Capabilities Application Part (TCAP) messages. The TCAP is an SS7 application protocol that can be used by various applications. It provides services that enable an application at one node to invoke execution of a procedure at remote node and to exchange the results of such invocation. Major role of TCAP is to facilitate transactions with external databases.

2. GPRS model

General Packet Radio Service (GPRS) is a cellular packet switching technology introduced by ETSI as an extension of the circuit switched Global System for Mobile Communications (GSM) standard. GPRS offers simple and resource-efficient access to external packet data networks, such as Internet. Packets from the GPRS mobile station (MS) can be directly routed to packet switched networks. GPRS also provides improved quality of data services in terms of throughput, reliability, and response time. It is an important migration step towards third-generation (3G) networks.

GPRS attempts to reuse existing GSM network elements as much as possible. Nevertheless, existing Mobile Switching Centers (MSCs) are based on circuit-switched technology and cannot handle packetized traffic. New network elements and protocols are required in order to effectively handle packet traffic. Therefore, GPRS introduces two new nodes, called GPRS support nodes, which are responsible for routing data packets between mobile stations and external packet data networks:

- Serving GPRS Support Node (SGSN) is connected to a Base Station Controller (BSC) and delivers data packets to and from the mobile stations within its service area. SGSN is responsible for packet routing and transfer, mobility and location management, logical link management, and authentication and charging functions. It contains a location register that stores location information and subscription data of all GPRS users registered with the SGSN.
- Gateway GPRS Support Node (GGSN) is used as an interface to the external packet data networks. It is connected to SGSN via IP-based GPRS backbone. GGSN converts packets arriving from the SGSN into the appropriate packet data protocol (PDP) format (such as IP) and forwards them to other packet data networks.

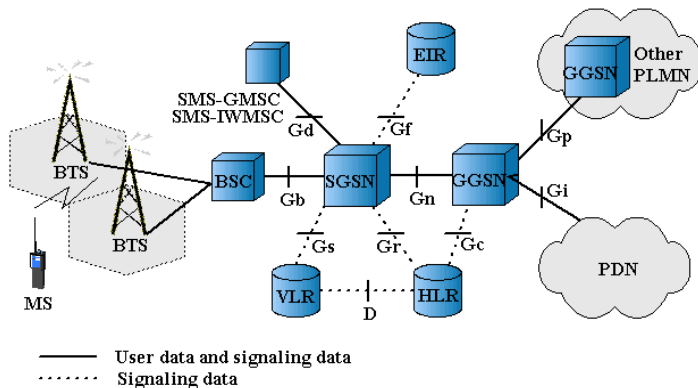

Figure 3: GPRS system architecture.

GPRS support nodes are connected to three distinct databases (Figure 3): Home Location Register (HLR), Visitors Location Register (VLR), and Equipment Identity Register (EIR).

- Home Location Register (HLR) is the main database of permanent subscriber information in a mobile network. It maintains GPRS subscription data and routing information. The HLR is accessible from the SGSN via Gr interface and, optionally, from the GGSN via Gc interface. The Gr interface is based on SS7 (Figure 4).

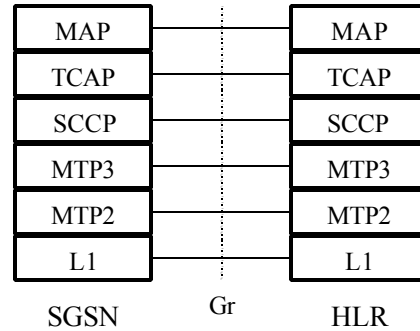

Figure 4: Gr interface protocol stack.

- Visitors Location Register (VLR) is a database similar to an HLR that contains temporary information about visiting (roaming) subscribers. The VLR data is based on the user information retrieved from an HLR. The VLR is connected to SGSN via Gs interface that is also based on SS7. The Gs interface employs Base Station System Application Part + (BSSAP+), instead of MAP, as a top layer protocol in the SS7 protocol stack.
- Equipment Identity Register (EIR) is a network database that stores lists of International Mobile Equipment Identity (IMEI) numbers. The IMEI is a unique code that corresponds to a specific GSM handset. The EIR is connected to SGSN via Gf interface and uses the same SS7 protocol stack as Gr interface shown in Figure 4.

GPRS OPNET model that we used to implement MAP protocol is described in [2]. It consists of network elements shown in Figure 5: MS, SGSN, GGSN, Internal HLR, and a sink that mimics an IP-based external network. Instead of an HLR using an SS7 network, a simplified version called Internal HLR was implemented in [2]. Instead of MAP, the SGSN used an internal database querying protocol to retrieve subscriber's data from the Internal HLR.

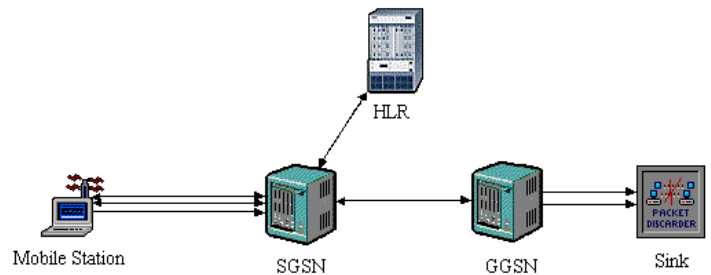

Figure 5: GPRS OPNET model.

3. MAP protocol implementation

MAP provides its users with a specified set of services. It can be viewed by its users as a “black box” or an abstract machine representing a MAP service-provider [3]. MAP service-user interacts with the MAP service-provider by issuing or receiving MAP service-primitives at the service interface. In our case, the MAP service-users are SGSN and HLR. The MAP service-provider acts as a TCAP service-user and communicates with TCAP service-provider by issuing or receiving TCAP service-primitives. Communication between the MAP service-user, MAP service-provider, and TCAP service-provider is illustrated in Figure 6.

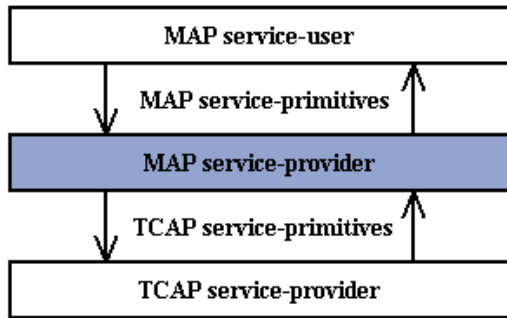

Figure 6: MAP service interfaces.

The MAP services (primitives) are classified as common MAP services (available to all MAP service-users) or MAP service-user specific services (specific to particular MAP service-user). The MAP services can be further classified as unconfirmed services (request, indication) or confirmed services (request, indication, response, confirm), depending on whether or not the service is confirmed by the service-provider. An example of a message exchange for a confirmed service is shown in Figure 7. For every implemented MAP service-primitive, we defined a distinct packet format in OPNET.

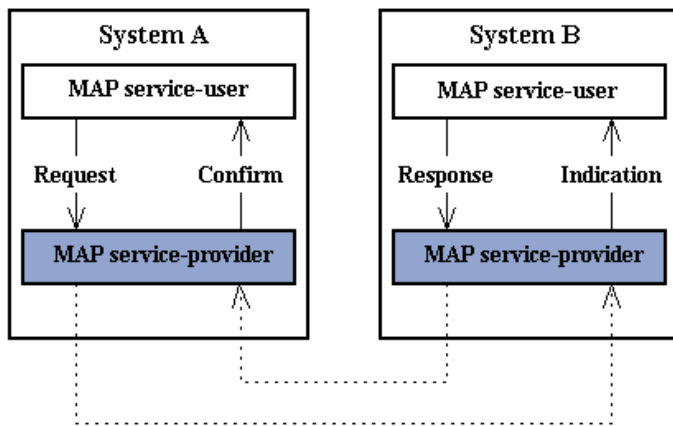

Figure 7: Example of a confirmed service.

3.1 Common MAP services

Common MAP services are required by all MAP service-users. They perform basic application layer functions, such as establishing and clearing MAP dialogues between MAP service-user peers, invoking services provided by the lower layer, and reporting abnormal situations. We implemented the following common MAP services:

- MAP-OPEN
- MAP-CLOSE
- MAP-DELIMITER
- MAP-U-ABORT
- MAP-P-ABORT
- MAP-NOTICE.

3.2 Service-user specific MAP services

Service-user specific MAP services are available only to particular service-users. They perform functions related to mobility management, location management, call handling, PDP context activation, short message service (SMS) management, and maintenance. We implemented only GPRS-related service-user specific MAP services:

- MAP-UPDATE-GPRS-LOCATION
- MAP-INSERT-SUBSCRIBER-DATA
- MAP-CANCEL-LOCATION
- MAP-DELETE-SUBSCRIBER-DATA
- MAP-PURGE-MS
- MAP-SEND-AUTHENTICATION-INFO
- MAP-RESET
- MAP-SEND-ROUTING-INFO-FOR-GPRS
- MAP-FAILURE-REPORT
- MAP-NOTE-MS-PRESENT-FOR-GPRS.

3.3 TCAP service primitives

The MAP protocol relies on the services provided by the Transaction Capabilities Application Part (TCAP). The term Transaction Capabilities (TC) refers to a set of communication capabilities that provide an interface between applications and a network layer service [4]. MAP services are mapped onto corresponding TC services (primitives). However, in our model, TC service-primitives are sent directly to the peer because layers below MAP have not been implemented. All TC services are unconfirmed. However, only TC service-request primitives are implemented. The requests are recognized as indications at the peer. The TC primitives are divided into dialogue-handling primitives and component-handling primitives. Dialogue-handling TC primitives that we implemented are:

- TC-BEGIN
- TC-CONTINUE
- TC-END
- TC-U-ABORT.

We implemented the following component-handling TC primitives:

- TC-INVOKE
- TC-RESULT-L
- TC-RESULT-NL
- TC-U-ERROR
- TC-U-CANCEL
- TC-U-REJECT.

3.4 MAP Protocol Machine

We implemented the MAP Protocol Machine (MAP PM) as a collection of Service State Machines (SSMs) coordinated by a

MAP Dialogue State Machine (DSM). Our model consists of two SSMS: Requesting Service State Machine (RSM) and Performing Service State Machine (PSM). The MAP PM is shown in Figure 8. All state machines are implemented in OPNET as finite state machines (FSMs).

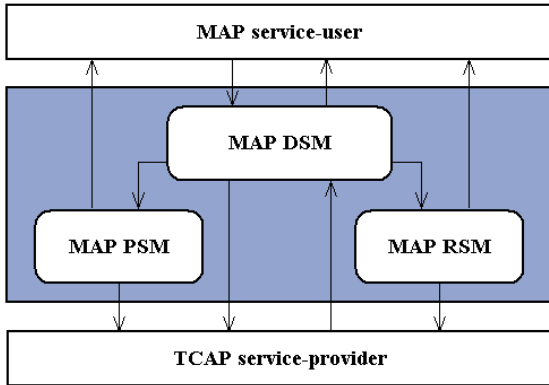

Figure 8: MAP protocol machine.

3.5 MAP Dialogue State Machine (DSM)

The establishment of a MAP dialogue involves one dialogue-initiator and one dialogue-responder. A new invocation of a MAP DSM is employed upon receipt of a MAP-OPEN request primitive from a MAP service-user at the dialogue-initiator's side or on the receipt of a TC-BEGIN indication primitive from a dialogue-initiator at the dialogue-responder's side. Each invocation controls exactly one MAP dialogue.

Figure 9 shows the MAP DSM OPNET process model. It consists of eight states:

- IDLE
- WAIT_FOR_INITIAL_DATA
- WAIT_FOR_COMPONENTS
- WAIT_FOR_USER_REQUESTS
- DIALOGUE_INITIATED
- DIALOGUE_PENDING
- DIALOGUE_ACCEPTED
- DIALOGUE_ESTABLISHED.

The behavior of the DSM depends on the application context associated with the dialogue. Application contexts available in our model are listed in Table 1.

| Application Context Name | Operations Used |
|----------------------------------|--|
| locationCancellationContext | cancelLocation |
| infoRetrievalContext | sendAuthenticationInfo |
| msPurgingContext | purgeMS |
| resetContext | reset |
| gprsLocationUpdateContext | updateGprsLocation insertSubscriberData |
| subscriberDataMngtContext | insertSubscriberData deleteSubscriberData |
| gprsNotifyContext | noteMsPresentForGprs |
| gprsLocationInfoRetrievalContext | sendRoutingInfoForGprs |
| failureReportContext | failureReport |

Table 1: Application contexts and associated operations.

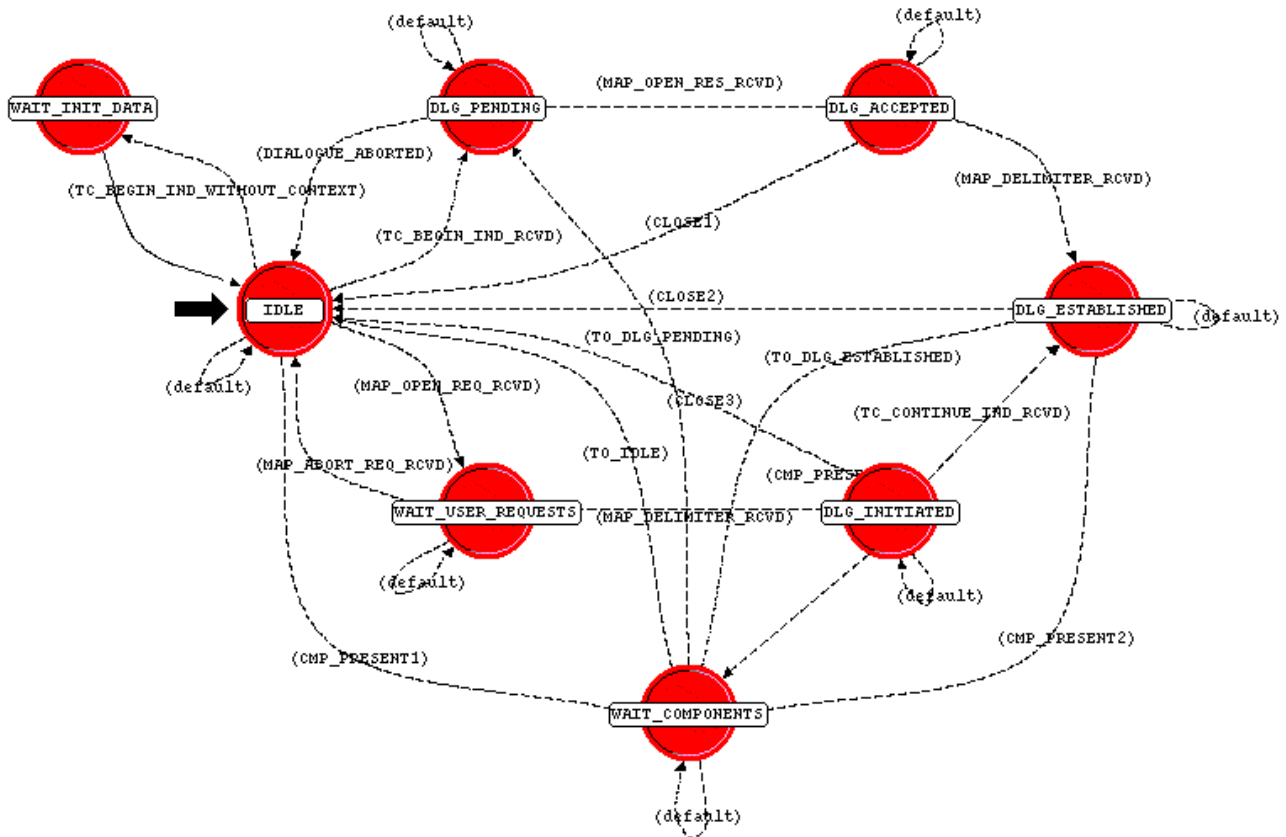

Figure 9: MAP Dialogue State Machine.

3.6 MAP Performing Service State Machine (PSM)

The Performing Service State Machine handles service-user specific services invoked by the peer. It is implemented in OPNET as a simple process model with two states: IDLE and WAIT_FOR_RESPONSE, as shown in Figure 10.

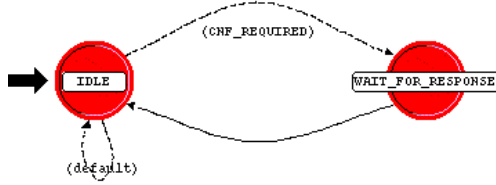

Figure 10: MAP Performing Service State Machine.

3.7 MAP Requesting Service State Machine (RSM)

The Requesting Service State Machine handles service-user specific services requested by the MAP service-user. The OPNET RSM process model consists of two states: IDLE and WAIT_FOR_CONFIRM, as shown in Figure 11.

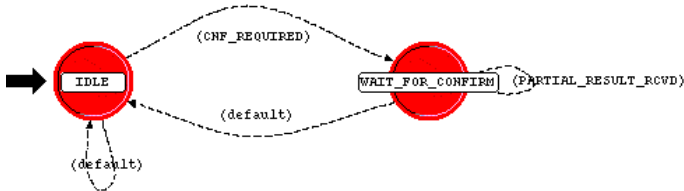

Figure 11: MAP Requesting Service State Machine.

3.8 Simplifications to the MAP protocol implementation

To reduce the complexity of the implementation, we made several simplifications and modifications to the behavior defined in the MAP specification [3]:

- MAP-READY-FOR-SM, MAP-ACTIVATE-TRACE-MODE, and MAP-DEACTIVATE-TRACE-MODE service-user specific services are not implemented.
- TC-NOTICE dialogue-handling TC primitive is not implemented.
- TC-TIMER-RESET, TC-L-REJECT, TC-R-REJECT, and TC-P-ABORT component-handling TC primitives are not implemented.
- One instance of PSM (RSM) should be created by the MAP DSM for each MAP service to be performed (requested). However, only one instance of the PSM (RSM) is implemented in our model. Hence, only one MAP service can be handled at a time.
- MAP DSM should wait for MAP-DELIMITER request from the service-user before issuing TC-BEGIN request [3]. In our model, a TC-BEGIN request is sent to the peer immediately after every service-user specific MAP request.
- MAP DSM should issue TC-CONTINUE request after it receives a MAP-DELIMITER request from the service-user [3]. In our model, after every service-user specific response issued by the MAP service-user, the PSM immediately sends a TC-CONTINUE request to the peer.

4. HLR and SGSN node models

We modified the HLR and SGSN node models in the original GPRS model [2] to support MAP based signaling between these two nodes. The additional process models are marked in Figures 12 and 13. The remainder of the model is identical as in [2].

Figure 12 shows the SGSN node model. In this case, MAP service-user is implemented as a separate process model. However, it could be considered as a part of the SGSN process model that interacts with the MAP service-provider. We kept the original SGSN process model almost unchanged. One transmitter-receiver pair is used for communication with the HLR.

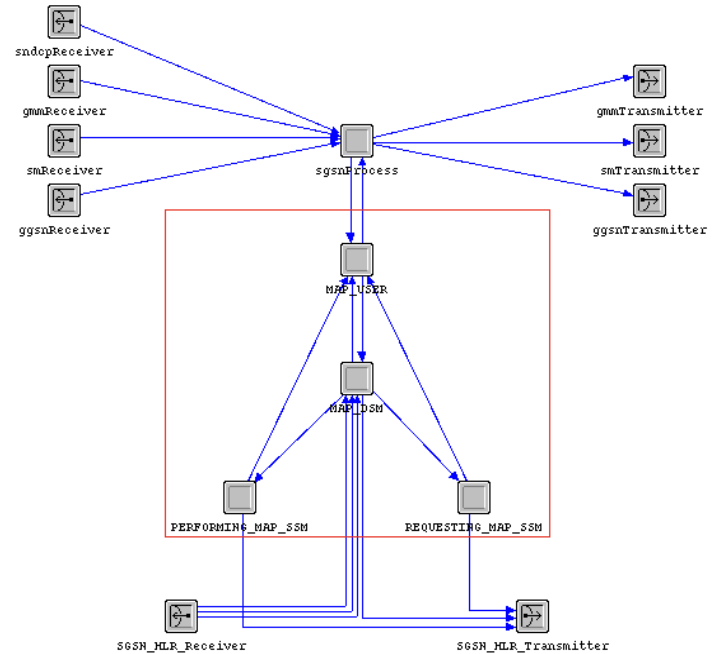

Figure 12: OPNET SGSN node model.

The HLR node model is shown in Figure 13. The HLR process model above MAP is adapted to act as a MAP service-user. One transmitter-receiver pair is used for communication with the SGSN. The second pair is provided for an optional Gc interface with GGSN that has not yet been implemented.

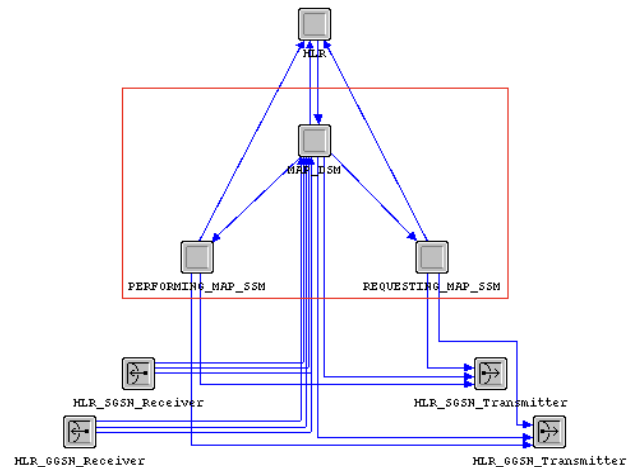

Figure 13: OPNET HLR node model.

4.1 Interaction between SGSN and HLR

Before a mobile station (MS) can use GPRS services, it must register with an SGSN of the GPRS network [5]. The user profile is then copied from the HLR to the SGSN. This procedure is called GPRS attach.

A conceptual description of message exchange in our model during the attach procedure is presented in Figure 14:

1. In an Attach Request to the SGSN, the mobile station provides its International Mobile Station Identity (IMSI) number.
2. The SGSN sends an Update GPRS Location to the HLR.
3. The HLR sends Insert Subscriber Data with GPRS subscription data to the new SGSN.
4. The SGSN returns an Insert Subscriber Data Ack message to the HLR.
5. The HLR acknowledges the Update GPRS Location message by sending an Update GPRS Location Ack to the SGSN.
6. The SGSN sends an Attach Accept message to the MS.
7. The MS acknowledges the received Attach Accept by returning an Attach Complete message to the SGSN.

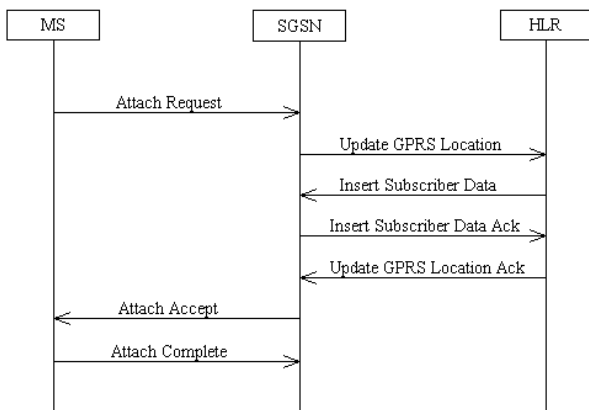

Figure 14: Description of the attach procedure.

Message exchange between the SGSN and HLR is handled by MAP entities in these two nodes. The message sequence chart for attach procedure is shown in Figure 15. This message exchange represents a single MAP dialogue. The dialogue is initiated when SGSN receives an Attach Request from an MS. During this dialogue, application context is set to `gprsLocationUpdateContext`. Two operations are performed: `updateGprsLocation` and `insertSubscriberData` (Table 1). When the dialogue with the HLR ends, the SGSN sends an Attach Accept or Attach Reject message to the MS, depending on the outcome of the dialogue.

5. Verification results

In order to compare the original model (with an internal HLR) with the new model that includes MAP interface between HLR and SGSN, we tested our model using the same simulation scenario as described in [2]. However, we were only interested in the attach procedure during simulation because that is the only procedure in the GPRS model where interaction between SGSN and HLR takes place.

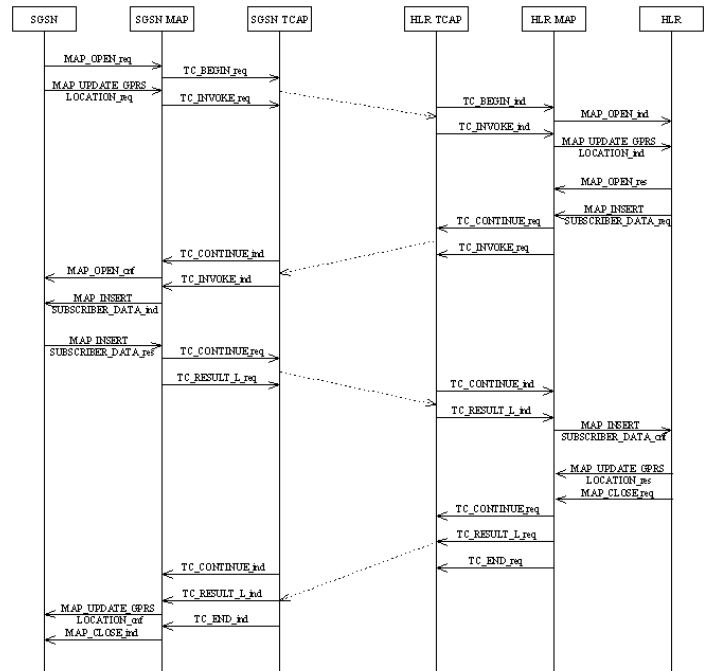

Figure 15: MAP dialogue for the attach procedure.

In our simulation scenario, there are 15 mobile stations sending Attach Requests to SGSN. However, HLR does not contain subscription profiles of all mobile stations. Mobile stations whose profiles cannot be found in the HLR will be rejected during the attach procedure.

Figures 16 and 17 show the number of signaling messages processed during the simulation. Results shown in Figure 16 are obtained using the original GPRS model without MAP, while the results shown in Figure 17 are obtained using our new model. Both diagrams show that the same number of Attach Requests, Attach Accepts, and Attach Rejects is processed during the simulated period. The number of Attach Requests is equal to the number of Attach Accepts plus the number of Attach Rejects.

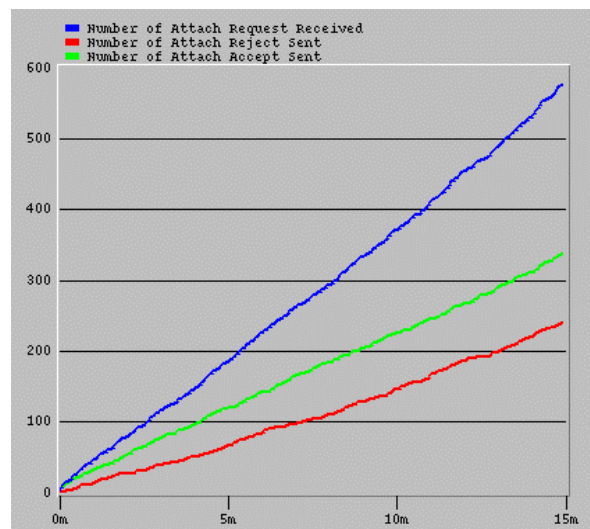

Figure 16: Original model: number of processed Attach Requests (top), Attach Accepts (middle), and Attach Rejects (bottom).

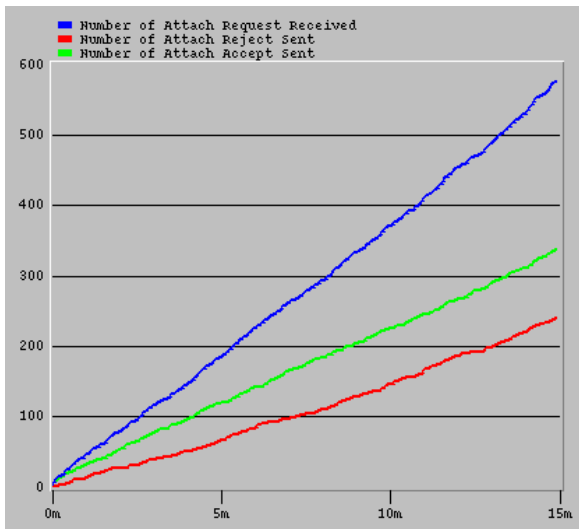

Figure 17: New model: number of processed Attach Requests (top), Attach Accepts (middle), and Attach Rejects (bottom) is equivalent to the original model.

This result verifies that MAP signaling interface that we implemented does not affect the results of attach attempts, namely, none of the Attach Requests will be rejected because of the MAP protocol itself or a potential error in the protocol design. Furthermore, all Attach Requests that should be rejected because subscription data cannot be found in the HLR will be rejected.

6. Impact of protocol overhead on network response

In order to evaluate the influence of MAP signaling on the network performance, we measured the processing time of the attach procedure. The processing time is measured at the MS from the moment when an Attach Request is sent, until an Attach Accept or Attach Reject is received. We expected a significant increase in the processing time of the Attach Request because of intensive message exchanges between MAP entities. However, comparison between the processing time using the new model and the processing time using the original model that employs a very simple internal protocol for communication with HLR indicates an average increase of only 30%. The average duration of the attach procedure in the original model is 77 ms. It increased to 100 ms in the new model. The simulation results are shown in Figures 18 and 19.

7. Conclusions

In this paper, we described the OPNET implementation of Mobile Application Part (MAP) protocol. The MAP protocol model is a collection of Service State Machines. Dialogue State Machine (DSM) handles dialogues between peers, while Requesting State Machine (RSM) and Performing State Machine (PSM) are responsible for service-user specific services. We implemented MAP protocol in OPNET because its Finite State Machine (FSM) concept was well suited for this purpose. This implementation has been employed for signaling procedures within General Radio Packet Service (GPRS) network model [2]. In order to enable MAP-based signaling between Serving GPRS Support Node (SGSN) and Home Location Register (HLR), we implemented necessary modifications in these two nodes. Services provided by the MAP model are illustrated using an example that describes the attach procedure in GPRS. Finally,

we measured processing times of the attach procedure to evaluate the effect of MAP protocol on network performance.

The existing GPRS model could be further enhanced to fully utilize services provided by MAP. That would help assess the impact of SS7 signaling and MAP protocol as its top layer on the performance of a genuine wireless network, especially with respect to mobility management procedures.

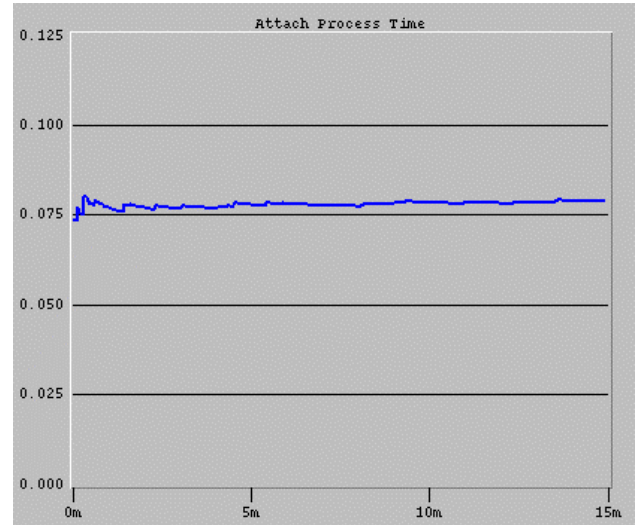

Figure 18: Original model: duration of the attach procedure.

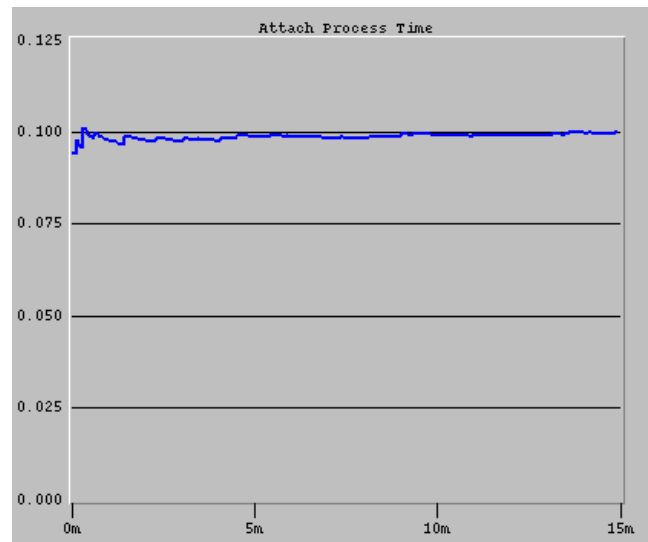

Figure 19: New model: duration of the attach procedure is higher than in the original model.

References

- [1] Cisco SS7 Fundamentals: http://www.cisco.com/univercd/cc/td/doc/product/tel_pswt/vco_prod/ss7_fund/index.htm (March 2003).
- [2] R. Ng and Lj. Trajkovic, "Simulation of general packet radio service network," OPNETWORK 2002, Washington, DC, August 2002.
- [3] 3rd Generation Partnership Project, TS 09.02 v7.12.0, Mobile Application Part (MAP) specification.

[4] ITU-T Q.771, Specifications of Signalling System No. 7, Transaction capabilities application part.

[5] 3rd Generation Partnership Project, TS 03.60 v7.9.0, General Packet Radio Service (GPRS), Service Description.

Appendix

A. MAP service primitives

A.1 Common MAP services

- MAP-OPEN: confirmed service used for establishing a MAP dialogue between two MAP service-users.
- MAP-CLOSE: unconfirmed service used for releasing a previously established MAP dialogue.
- MAP-DELIMITER: unconfirmed service used to explicitly request the transfer of the MAP protocol data units to the peer entities.
- MAP-U-ABORT: unconfirmed service that enables the service-user to request MAP dialogue to be aborted
- MAP-P-ABORT: unconfirmed service that enables the MAP service-provider to abort a MAP dialogue.
- MAP-NOTICE: unconfirmed service used to notify the MAP service-user about protocol problems related to a MAP dialogue not affecting the state of the protocol machines.

A.2 Service-user specific MAP services

- MAP-UPDATE-GPRS-LOCATION: confirmed service used by the SGSN to update the location information stored in the HLR.
- MAP-INSERT-SUBSCRIBER-DATA: confirmed service used by an HLR to update a SGSN with subscriber data if the GPRS subscription has changed or if the network access mode is changed. Furthermore, during GPRS location updating of the subscriber, HLR provides the SGSN with subscriber parameters using this service.
- MAP-CANCEL-LOCATION: confirmed service used between HLR and SGSN to delete a subscriber record from the SGSN.
- MAP-DELETE-SUBSCRIBER-DATA: confirmed service used by an HLR to remove GPRS subscription data from the SGSN.
- MAP-PURGE-MS: confirmed service used between the SGSN and the HLR to cause the HLR to mark its data for an MS so that any request for routing information will be treated as if the MS was not reachable.
- MAP-SEND-AUTHENTICATION-INFO: confirmed service used between the SGSN and the HLR for the SGSN to retrieve authentication information from the HLR.
- MAP-RESET: unconfirmed service used by the HLR after a restart to indicate to the SGSN that a failure occurred.

- MAP-SEND-ROUTING-INFO-FOR-GPRS: confirmed service used by the GGSN to request GPRS routing information from the HLR.

- MAP-FAILURE-REPORT: confirmed service used by the GGSN to inform the HLR that network requested PDP-context activation has failed.

- MAP-NOTE-MS-PRESENT-FOR-GPRS: confirmed service used by the HLR to inform the GGSN that the MS is present.

B. TCAP service primitives

B.1 Dialogue-handling TC primitives

- TC-BEGIN: used by the MAP to propose a new dialogue to the peer.
- TC-CONTINUE: using this primitive MAP indicates that it wants to continue a dialogue proposed in the previously sent TC-BEGIN request.
- TC-END: used by the MAP to end a dialogue.
- TC-U-ABORT: abort requested by MAP, which causes all pending operations for the dialogue to be terminated.

B.2 Component-handling TC primitives

- TC-INVOKE: used by the MAP to invoke an operation at the peer.
- TC-RESULT-L: used to indicate that an operation has been executed by the peer. Indicates the result or the last segment of the result.
- TC-RESULT-NL: used to indicate that an operation has been executed by the peer. Indicates a segment of a result with additional segments to follow.
- TC-U-ERROR: indicates that the peer has received operation invocation that it cannot execute, although it recognizes it.
- TC-U-CANCEL: terminates the corresponding operation invocation.
- TC-U-REJECT: used by the MAP to reject any component generated by its peer entity that it considers incorrect.

C. MAP Protocol Machine (MAP PM) states

C.1 MAP Dialogue State Machine (DSM) states

- IDLE: This is initial state where the DSM waits for dialogue requests. When an interrupt has been received from the MAP service-user indicating a MAP-OPEN request message, application context present in the message is stored and the DSM proceeds to the WAIT_FOR_USER_REQUESTS state. If a TC-BEGIN indication has been received from the peer, two cases are possible depending on whether application context is present in the message or not. If application context is not present, the DSM proceeds to WAIT_FOR_INITIAL_DATA state, otherwise a MAP-OPEN

indication is sent to the MAP service-user and DSM proceeds to the WAIT_FOR_COMPONENTS state. If the application context is not recognized or not supported, a TC-U-ABORT request is sent to the peer and the DSM stays in the IDLE state.

- **WAIT_FOR_INITIAL_DATA:** When a TC-INVOKE indication has been received invoking an existing operation, a MAP-OPEN indication is sent to the MAP service-user and the DSM proceeds to the IDLE state. If the operation does not exist or another primitive is received instead of the TC-INVOKE indication, a TC-U-ABORT request is sent to the peer and the DSM proceeds to the IDLE state.

- **WAIT_FOR_COMPONENTS:** When a TC-INVOKE indication has been received invoking an existing operation, the service invocation is sent to the Performing Service State Machine (PSM). If the TC-INVOKE indication is trying to invoke an operation that does not exist, a TC-U-REJECT request is sent to the peer. If the DSM receives TC-RESULT-L, TC-RESULT-NL, TC-U-ERROR, or TC-U-REJECT indication, it will forward this indication to the RSM. If this was the last expected TC indication, the DSM will move to the IDLE, DIALOGUE_PENDING, or DIALOGUE_ESTABLISHED state, depending on the previous state of the DSM. Otherwise, it will stay in the WAIT_FOR_COMPONENTS state.

- **WAIT_FOR_USER_REQUESTS:** If any service-user specific request has been received from the MAP service-user, a TC-BEGIN request is sent to the peer and the service invocation is sent to the Requesting Service State Machine (RSM). The DSM proceeds to the DIALOGUE_INITIATED state. If a MAP-U-ABORT request has been received from the MAP service-user, a TC-U-ABORT request is sent to the peer, the RSM is terminated, and the DSM proceeds to the IDLE state.

- **DIALOGUE_INITIATED:** When a TC-END indication or a TC-CONTINUE indication has been received, its application context field is examined. If it is identical to the present application context of the dialogue, a MAP-OPEN confirmation is sent to the MAP service-user indicating “dialogue accepted” and the DSM proceeds to the WAIT_FOR_COMPONENTS state. The next TC-CONTINUE indication will cause termination of the PSM and RSM. A MAP-CLOSE indication is sent to the MAP service user and the DSM proceeds to the IDLE state. If the application context does not match the present application context of the dialogue, a MAP-P-ABORT request is sent to the MAP service-user, both PSM and RSM are terminated, and the DSM proceeds to the IDLE state. If a TC-U-ABORT indication has been received, a MAP-OPEN confirmation is sent to the MAP service-user indicating “dialogue refused”, the PSM and RSM are terminated, and the DSM proceeds to the IDLE state. When the DSM receives a MAP-U-ABORT request from the service-user, a TC-U-ABORT request is sent to the peer and the dialogue is terminated the same way as in the previous case. If a MAP-CLOSE request has been received, the DSM sends a TC-END request to the peer and terminates the dialogue.

- **DIALOGUE_PENDING:** When a MAP-OPEN response has been received, indicating in its “result” field that dialogue is accepted, the DSM proceeds to DIALOGUE_ACCEPTED state. If the “result” is negative, or a MAP-U-ABORT request has been received, a TC-U-ABORT request is sent to the peer and the dialogue is terminated.

- **DIALOGUE_ACCEPTED:** If any service-user specific request has been received from the MAP service-user, a TC-CONTINUE request is sent to the peer and the service invocation is sent to the Requesting Service State Machine (RSM). If any service-user specific response has been received, the response is sent to the Performing Service State Machine (PSM). The arrival of a MAP-DELIMITER request will cause a TC-CONTINUE request to be sent to the peer. When the DSM receives a MAP-CLOSE request, it sends a TC-END request to the peer and terminates the dialogue. If a MAP-U-ABORT request has been received, a TC-U-ABORT request is sent to the peer and the dialogue is terminated.

- **DIALOGUE_ESTABLISHED:** In this state, DSM handles all primitives received from the MAP service-user in the same way as in the DIALOGUE_ACCEPTED state. However, messages from the peer are treated differently. If TC-CONTINUE indication has been received, the DSM moves to the WAITING_FOR_COMPONENTS state. When a TC-END indication has been received, a MAP-CLOSE indication is sent to the service user and the dialogue is terminated. If a TC-U-ABORT indication has been received, the DSM sends MAP-P-ABORT to the service-user and terminates the dialogue.

C.2 MAP Performing Service State Machine (PSM) states

- **IDLE:** When the PSM receives service invocation from the DSM, it sends a corresponding MAP indication to the service-user and checks if a confirmation is required. If a confirmation is required, the PSM proceeds to WAIT_FOR_RESPONSE state.

- **WAIT_FOR_RESPONSE:** When an expected response has been issued by the MAP service-user, the PSM examines the “user error” field. If it indicates an error, a TC-U-REJECT request is sent to the peer. Otherwise, the PSM sends a TC-CONTINUE request and a TC-RESULT-L request to the peer. Once the response has been issued, the PSM moves back to the IDLE state.

C.3 MAP Requesting Service State Machine (RSM) states

- **IDLE:** When the PSM receives service invocation from the DSM, it sends a TC-INVOKE request to the peer and checks if a confirmation is required, in which case the RSM proceeds to WAIT_FOR_CONFIRM state.

- **WAIT_FOR_CONFIRM:** If the RSM receives a TC-RESULT-L indication, it issues a corresponding confirmation to the MAP service-user. If a TC-U-ERROR or TC-U-REJECT indication has been received, the RSM sets the “user error” field in a corresponding MAP confirmation and sends it to the MAP service-user.