

Phys101 Lectures 8 and 9

Conservation of Mechanical Energy

Key points:

- **Conservative and Nonconservative Forces**
- **Potential Energy**
- **Generalized work-energy principle**
- **Mechanical Energy and Its Conservation**

Ref: 6-4,5,6,8,9,10.

Conservative and Nonconservative Forces

A force is conservative if:

the work done by the force on an object moving from one point to another depends only on the initial and final positions of the object, and is independent of the particular path taken.

Example: gravitational force

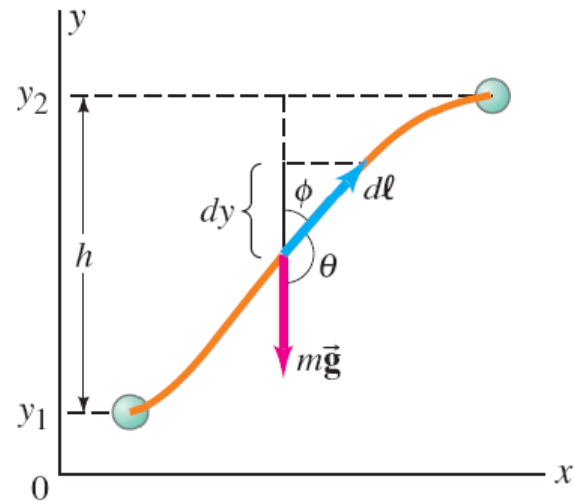
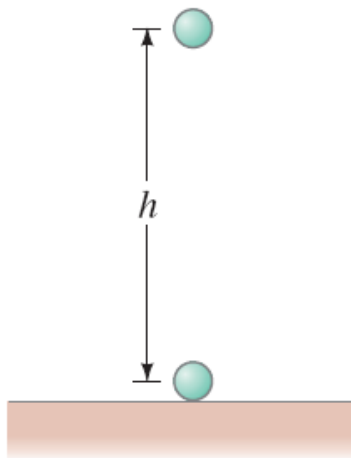

Another definition of a conservative force:

a force is conservative if the net work done by the force on an object moving around any closed path is zero.

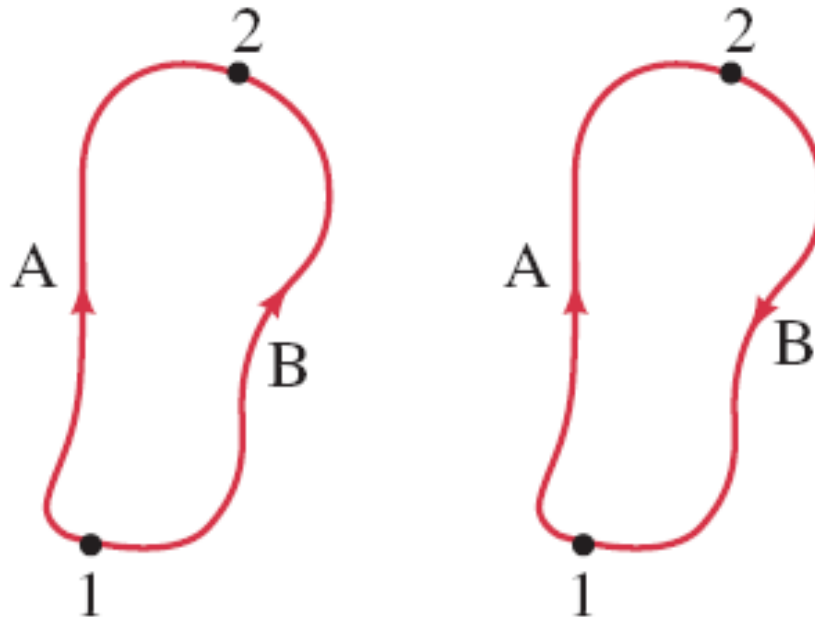

Conservative and Nonconservative Forces

If friction is present, the work done depends not only on the starting and ending points, but also on the path taken. Frictional force is a nonconservative force.

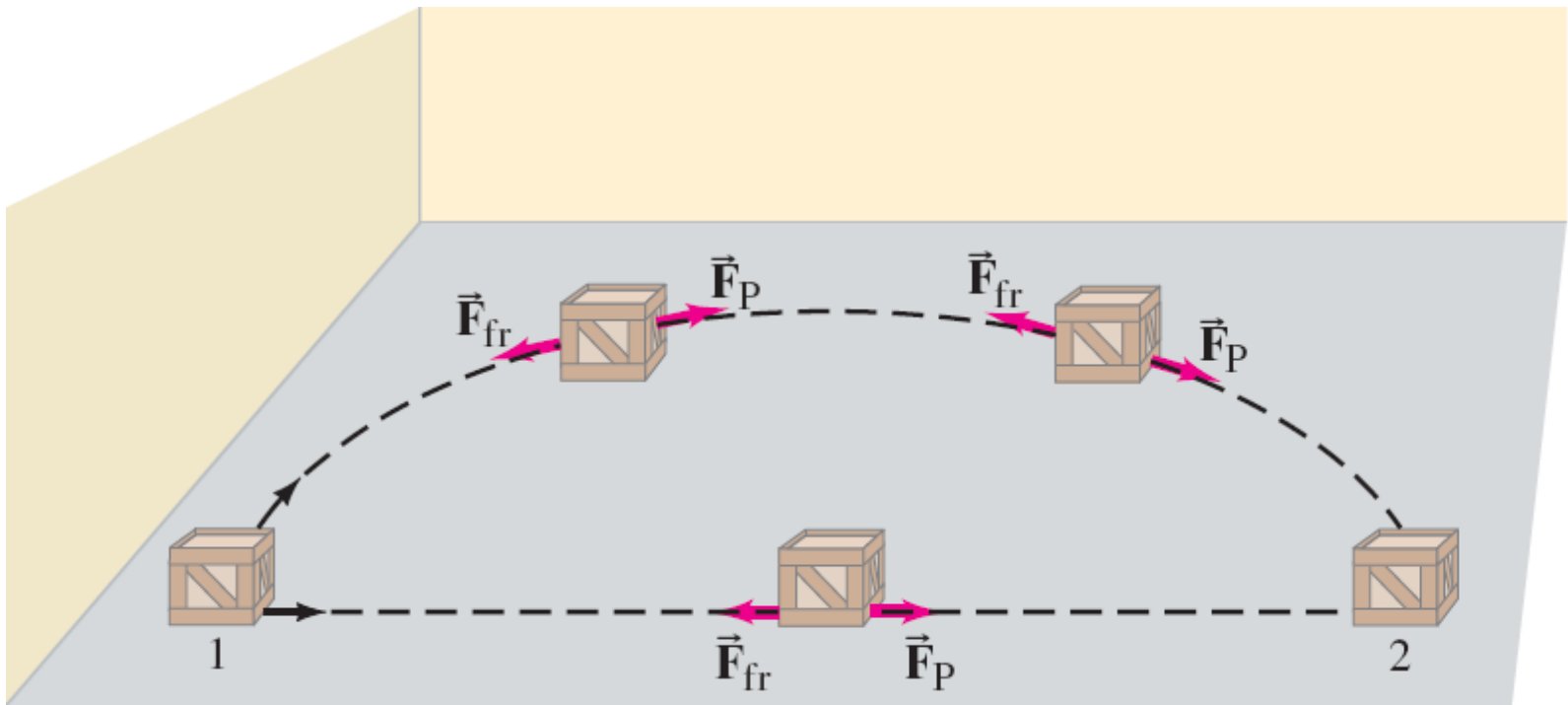

Conservative and Nonconservative Forces

TABLE 6–1 Conservative and Nonconservative Forces

Conservative Forces	Nonconservative Forces
Gravitational	Friction
Elastic	Air resistance
Electric	Tension in cord
	Motor or rocket propulsion
	Push or pull by a person

Potential energy can be defined for conservative forces.

Gravitational Potential Energy

In raising a mass m from y_1 to y_2 by a height h , the work done by the external force is

$$\begin{aligned}W_{\text{ext}} &= \vec{\mathbf{F}}_{\text{ext}} \cdot \vec{\mathbf{d}} = mgh \cos 0^\circ \\ &= mgh = mg(y_2 - y_1)\end{aligned}$$

The gravitational potential energy is raised by

$$\Delta U_G = mg(y_2 - y_1) = mgh$$

The work done by the gravitational force

$$W_G = m\vec{\mathbf{g}} \cdot \vec{\mathbf{d}} = -mg(y_2 - y_1) = -mgh$$

Therefore,

$$W_G = -\Delta U_G$$

The work done by the gravitational force is equal to the loss in potential energy.

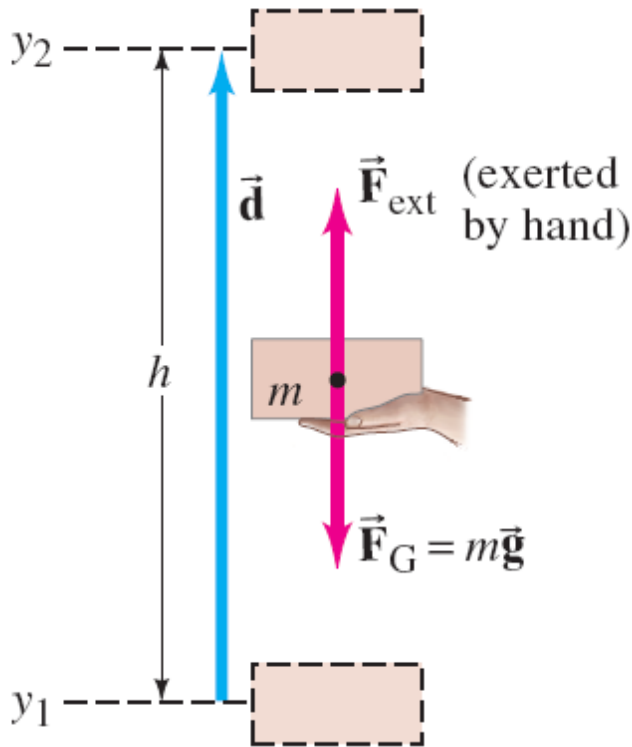

General Definition of Potential Energy

For any conservative force \vec{F}_C

$$\Delta U = -W_C$$

i.e., the change in potential energy is equal to the negative work done by the conservative force.

Or, the work done by the conservative force is equal to the loss in potential energy. i.e.,

$$W_C = -\Delta U = -(U_{final} - U_{initial})$$

Note: we have defined the change in potential energy ΔU , not the potential energy itself. That is why we can arbitrary choose the zero point of potential energy U .

What is potential energy?

It's a position-determined capability of doing work.

Example: Potential energy changes for a roller coaster.

A 1000-kg roller-coaster car moves from point 1 to point 2 and then to point 3. (a) What is the gravitational potential energy at points 2 and 3 relative to point 1? That is, take $y = 0$ at point 1. (b) What is the change in potential energy when the car goes from point 2 to point 3? (c) Repeat parts (a) and (b), but take the reference point ($y = 0$) to be at point 3.

$$(a) \quad U_2 = mgy_2 = (1000)(9.8)(10) = 9.8 \times 10^4 \text{ (J)}$$
$$U_3 = mgy_3 = (1000)(9.8)(-15) = -1.5 \times 10^5 \text{ (J)}$$

$$(b) \quad U_3 - U_2 = (-1.5 \times 10^5) - 9.8 \times 10^4$$
$$= -2.5 \times 10^5 \text{ (J)}$$

$$(c) \quad U_2 = mgy_2 = (1000)(9.8)(25) = 2.5 \times 10^5 \text{ (J)}$$
$$U_3 = mgy_3 = (1000)(9.8)(0) = 0$$

$$U_3 - U_2 = 0 - 2.5 \times 10^5$$
$$= -2.5 \times 10^5 \text{ (J)}$$

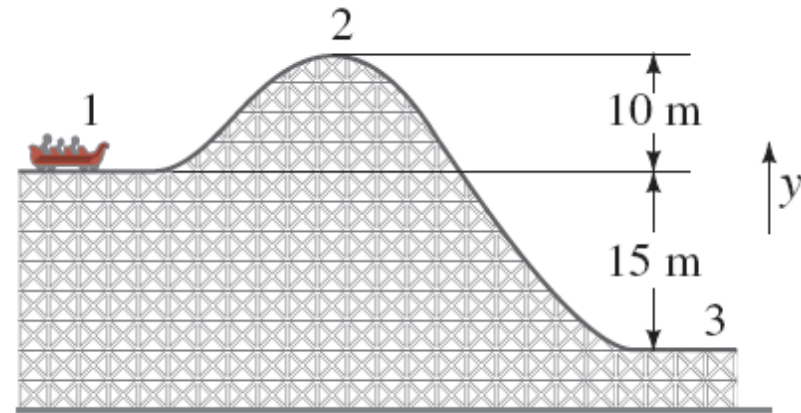

A spring has potential energy, called elastic potential energy.

It is convenient to choose $x=0$ at the equilibrium position as well as the zero point of the elastic potential energy. Then if we stretch the spring by x , the elastic potential energy is

$$U_{el}(x) = U_{el}(x) - U_{el}(0) = -W_{el} = \frac{1}{2}kx^2$$

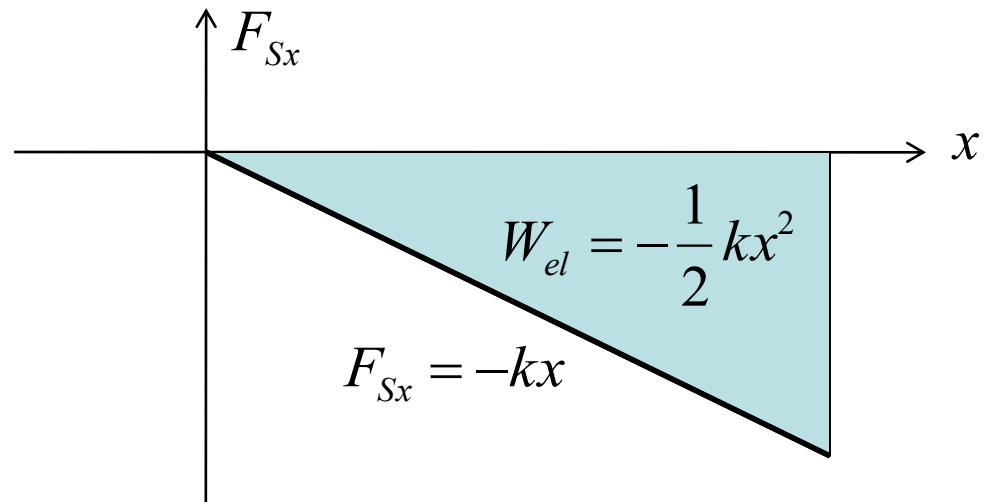
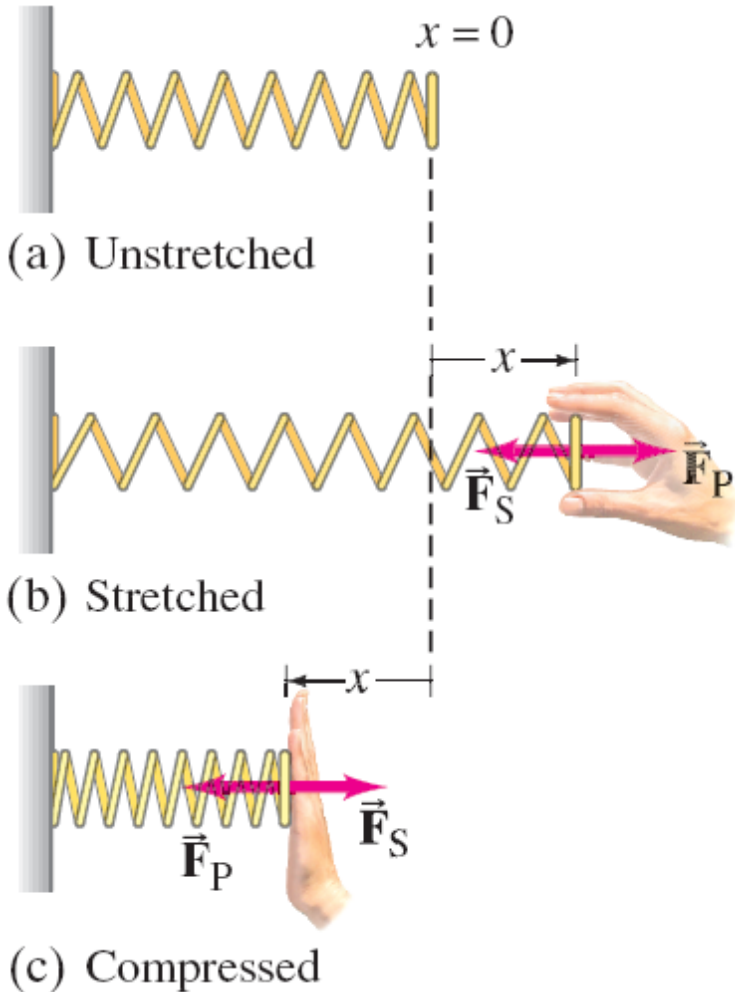

When we stretch (or compress) the spring by x , we raise the potential energy by $kx^2/2$.

From the Work-Energy Principle to Conservation of Mechanical Energy

The work-energy principle: $W_{\text{net}} = \Delta K = \frac{1}{2}mv_2^2 - \frac{1}{2}mv_1^2.$

Since there are conservative and nonconservative forces,

$$W_{\text{net}} = W_C + W_N = \Delta K$$

and the conservative work is equal to the loss in potential energy

$$-\Delta U + W_N = \Delta K$$

Therefore

$$W_N = \Delta K + \Delta U = \Delta E$$

Generalized work-energy principle: The total nonconservative work done on a system is equal to the gain in mechanical energy of the system. The mechanical energy is the sum of the potential energy and kinetic energy, i.e., $E=U+K$.

Special case:

when $W_N=0$, $\Delta E=0$, i.e., $E=\text{const}$, or $E_{\text{final}} = E_{\text{initial}}$

This is known as the conservation of mechanical energy.

i-clicker question 9-1

The condition for mechanical energy to be conserved is

- (A) It's a closed system.**
- (B) The net force is zero.**
- (C) No nonconservative work.**
- (D) The mechanical energy is never conserved.**
- (E) The mechanical energy is always conserved.**

The principle of conservation of mechanical energy:

If only conservative forces are doing work, the total mechanical energy of a system neither increases nor decreases in any process. It stays constant—it is conserved.

How to use it to solve problems:

When ME is conserved, we have an equation $E_1 = E_2$, for any two states 1 and 2.

Conservation of Mechanical Energy

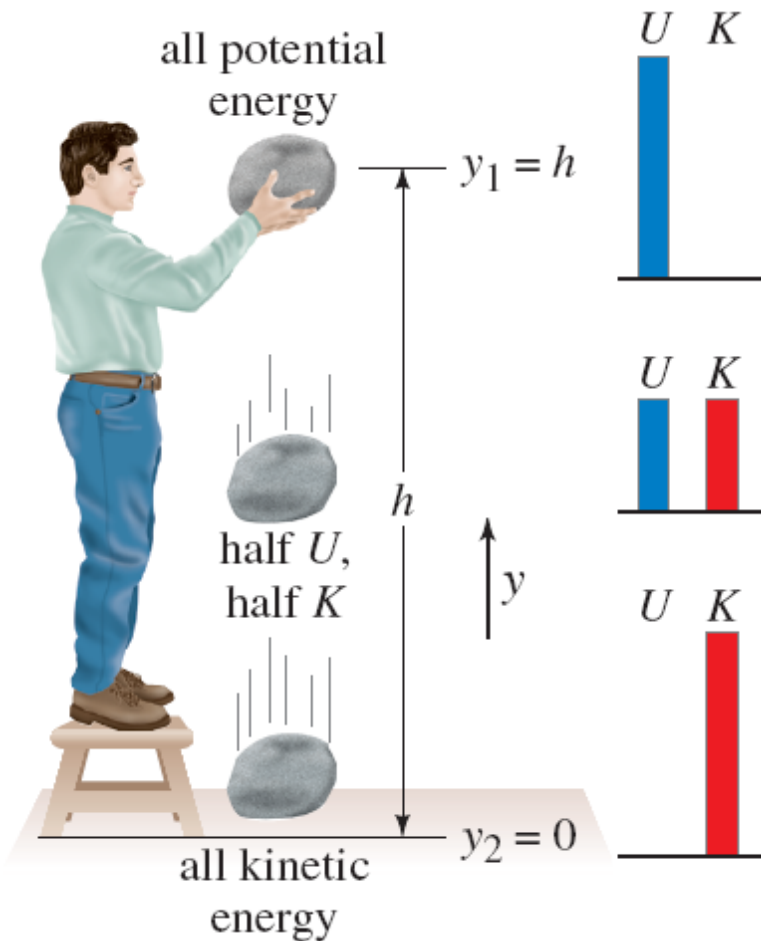

In the image on the left, the total mechanical energy at any point is:

$$E = K + U$$
$$= \frac{1}{2}mv^2 + mgy.$$

Example: Roller-coaster car speed using energy conservation.

Assuming the height of the hill is 40 m, and the roller-coaster car starts from rest at the top, calculate (a) the speed of the roller-coaster car at the bottom of the hill, and (b) at what height it will have half this speed. Take $y = 0$ at the bottom of the hill.

[Solution] No friction, $W_N=0$.
ME is conserved: $E=\text{constant}$

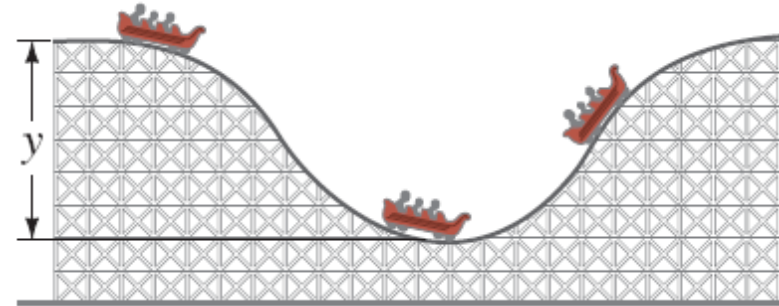

(a) Top: $K = 0$, $E = mgh_T$

Bottom: $U = 0$, $E = \frac{1}{2}mv_B^2$

$$\therefore mgh_T = \frac{1}{2}mv_B^2; \quad v_B = \sqrt{2gh_T} = \sqrt{2 \times 9.8 \times 40} = 28 \text{ m/s}$$

(b) At height y : $E = mgy + \frac{1}{2}mv^2$

$$\therefore \frac{1}{2}mv_B^2 = mgy + \frac{1}{2}m\left(\frac{v_B}{2}\right)^2$$

$$y = \frac{1}{2g} \frac{3v^2}{4} = \frac{3 \times 28^2}{8 \times 9.8} = 30 \text{ m}$$

Conservation of Mechanical Energy

For an elastic force, conservation of energy tells us:

$$\frac{1}{2}mv_1^2 + \frac{1}{2}kx_1^2 = \frac{1}{2}mv_2^2 + \frac{1}{2}kx_2^2.$$

Example: Toy dart gun.

A dart of mass 0.100 kg is pressed against the spring of a toy dart gun. The spring (with spring stiffness constant $k = 250$ N/m and ignorable mass) is compressed 6.0 cm and released. If the dart detaches from the spring when the spring reaches its natural length ($x = 0$), what speed does the dart acquire?

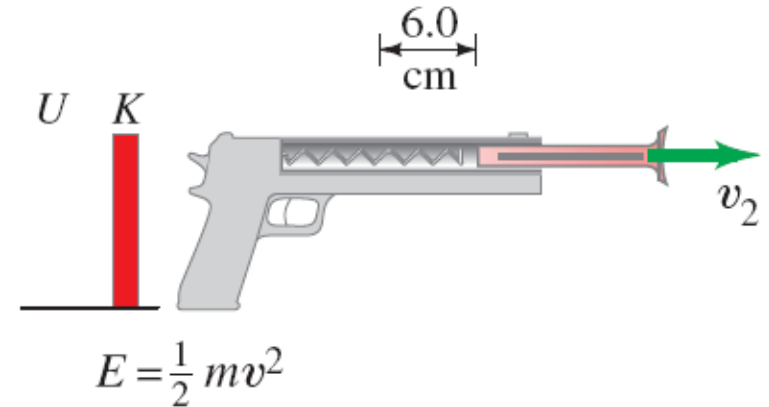
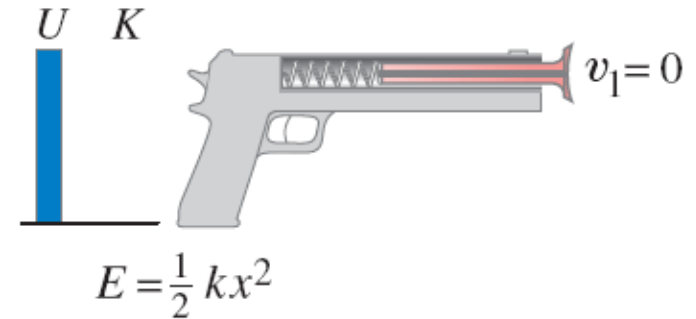

[Solution]

$$E_i = E_f, \quad \therefore \frac{1}{2}kx^2 = \frac{1}{2}mv^2, \quad v = \sqrt{\frac{k}{m}}x = \sqrt{\frac{250}{0.1}}0.06 = 3\text{ m/s}$$

Example: Two kinds of potential energy

A ball of mass $m = 2.60$ kg, starting from rest, falls a vertical distance $h = 55.0$ cm before striking a vertical coiled spring, which it compresses an amount $Y = 15.0$ cm. Determine the spring stiffness constant of the spring. Assume the spring has negligible mass, and ignore air resistance. Measure all distances from the point where the ball first touches the uncompressed spring ($y = 0$ at this point).

– why do we choose to do this?

Conservation of ME:

$$E_i = E_f \quad \Rightarrow \quad mgy_1 = \frac{1}{2}ky_3^2 + mgy_3$$

$$\text{Solve for } k: \quad k = \frac{2mg(y_1 - y_3)}{y_3^2} = \frac{2(2.6)(9.8)[0.55 - (-0.15)]}{(-0.15)^2} = 1590 \text{ N/m}$$

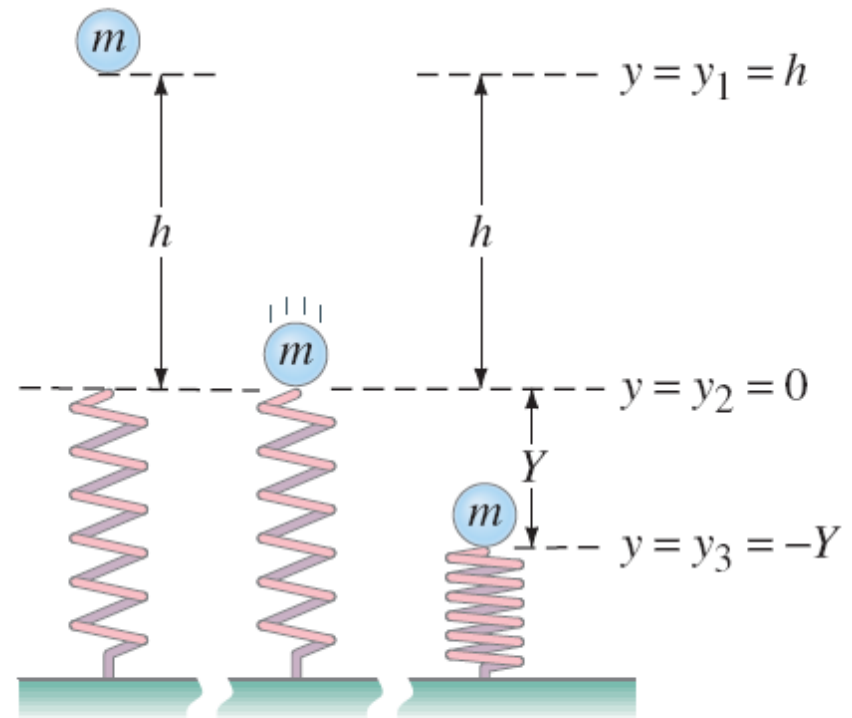

Example: A swinging pendulum.

This simple pendulum consists of a small bob of mass m suspended by a massless cord of length l . The bob is released (without a push) at $t = 0$, where the cord makes an angle $\theta = \theta_0$ to the vertical.

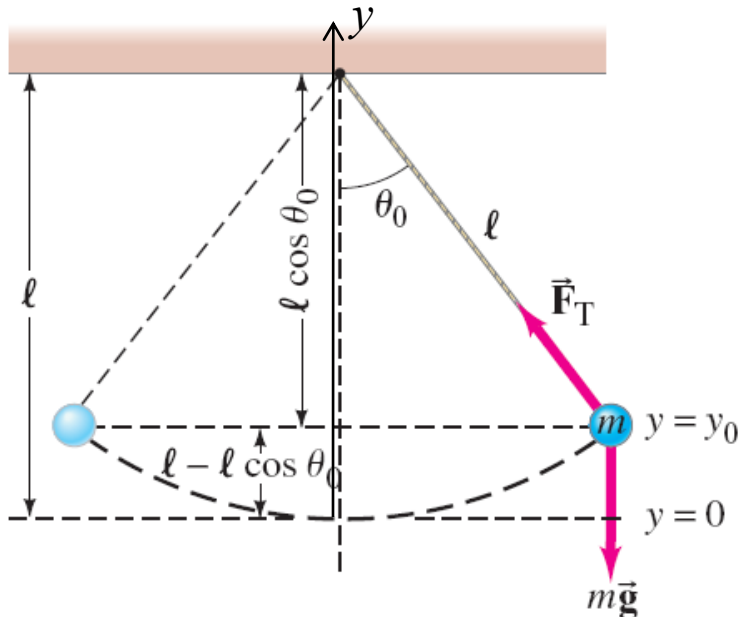

(a) Describe the motion of the bob in terms of kinetic energy and potential energy. Then determine the speed of the bob (b) as a function of position θ as it swings back and forth, and (c) at the lowest point of the swing.

Two forces acting on the bob: Tension and gravity. The tension is Perpendicular to the direction of motion and thus does no work. There is no non-conservative work, mechanical energy is conserved.

$$mgy + \frac{1}{2}mv^2 = mgy_0, \quad y = l - l \cos \theta$$

(b) $v = \sqrt{2g(y_0 - y)} = \sqrt{2gl(\cos \theta - \cos \theta_0)}$

(c) $v = \sqrt{2gl(\cos 0^\circ - \cos \theta_0)} = \sqrt{2gl(1 - \cos \theta_0)}$

Demo

The Law of Conservation of Energy

Nonconservative, or dissipative, forces:

friction

air resistance

push or pull by a person

motor or rocket propulsion

and more

do not conserve **mechanical energy**. However, when these forces are taken into account, the **total energy** is still conserved:

$$\Delta K + \Delta U + [\text{change in all other forms of energy}] = 0.$$

Compared to the generalized work-energy principle:

$$W_N = \Delta K + \Delta U = \Delta E$$

Non-conservative work converts mechanical energy to/from other forms of energy, such as thermal energy (heat) and chemical energy.

The Law of Conservation of Energy

The law of conservation of energy is one of the most important principles in physics.

The total energy is neither increased nor decreased in any process. Energy can be transformed from one form to another, and transferred from one object to another, but the total amount remains constant.

Energy Conservation with Dissipative Forces

Example: Friction on the roller-coaster car.

The roller-coaster car shown reaches a vertical height of only 25 m on the second hill before coming to a momentary stop. It traveled a total distance of 400 m.

Determine the thermal energy produced and estimate the average friction force (assume it is roughly constant) on the car, whose mass is 1000 kg.

[Solution] The thermal energy produced is equal to the loss in mechanical energy.

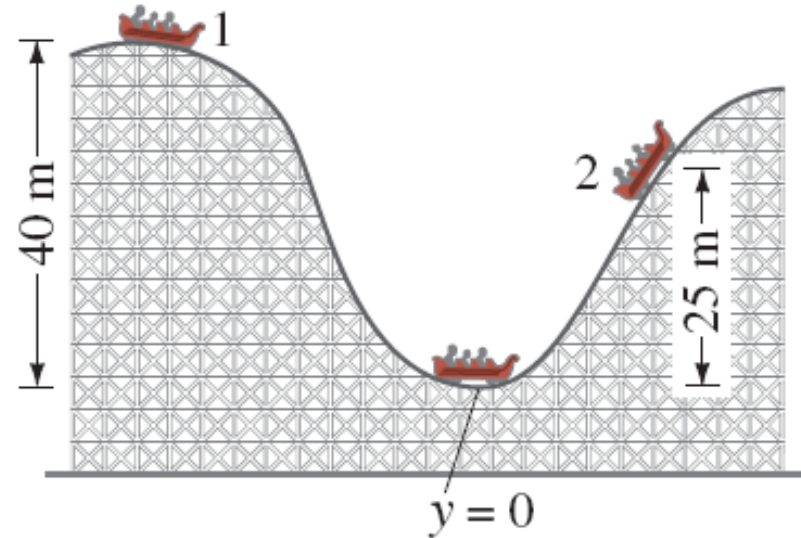

$$E_{TH} = -\Delta E = -(U_2 - U_1) = -(mgy_2 - mgy_1) = 147000 (J) \quad (K_i = K_f = 0)$$

$$W_N = -F_{fr}d = \Delta E = -E_{TH}$$

$$F_{fr} = \frac{E_{TH}}{d} = \frac{147000}{400} = 370 (N)$$

Work by friction is equal to the change in mechanical energy.

Example: Friction with a spring.

A block of mass m sliding along a rough horizontal surface is traveling at a speed v_0 when it strikes a massless spring head-on and compresses the spring a maximum distance X . If the spring has stiffness constant k , determine the coefficient of kinetic friction between block and surface.

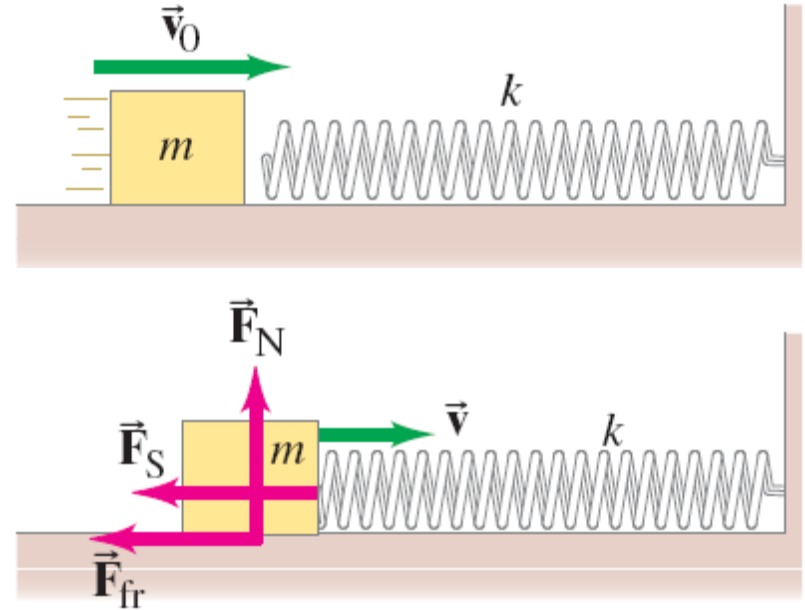

Note: It's very difficult to solve this problem using Newton's law, because the net force varies with time!

Use mechanical energy: $W_N = \Delta E = E_f - E_i$

$$W_N = \frac{1}{2} kX^2 - \frac{1}{2} mv_0^2, \quad W_N = \vec{F}_{fr} \cdot \vec{X} = -F_{fr}X = -\mu_k F_N X = -\mu_k mgX$$

$$\therefore -\mu_k mgX = \frac{1}{2} kX^2 - \frac{1}{2} mv_0^2, \quad \mu_k = \frac{v_0^2}{2gX} - \frac{kX}{2mg}$$

Power

Power is the rate at which work is done.

Average power:

$$\bar{P} = \frac{W}{t}.$$

Instantaneous power:

$$P = \frac{dW}{dt}.$$

In the SI system, the units of power are watts:

$$1 \text{ W} = 1 \text{ J/s}.$$

Power can also be described as the rate at which energy is transformed:

$$P = \frac{dE}{dt}.$$

Example: Stair-climbing power.

A 60-kg jogger runs up a long flight of stairs in 4.0 s. The vertical height of the stairs is 4.5 m. (a) Estimate the jogger's power output. (b) How much energy did this require?

[Solution]

$$(b) W_N = \Delta E = E_f - E_i = U_f - U_i, \quad (K=0)$$

$$W_N = mg\Delta y = 60 \times 9.8 \times 4.5 = 2600 \text{ (J)}$$

$$(a) P = W/t = 2600/4 = 650 \text{ (W)}$$



Power

Power is also needed for acceleration and for moving against the force of friction.

The power of a force can be written in terms of the force and the velocity:

$$P = \frac{dW}{dt} = \vec{\mathbf{F}} \cdot \frac{d\vec{\ell}}{dt} = \vec{\mathbf{F}} \cdot \vec{\mathbf{v}}.$$

Example: Power needs of a car.

Calculate the power required of a 1400-kg car under the following circumstances: (a) the car climbs a 10° hill (a fairly steep hill) at a steady 80 km/h. Assume that the average retarding force on the car is $F_R = 700$ N throughout.

[Solution]

$$P = \vec{F} \cdot \vec{v} = F_x v$$

$$v = 80 \text{ km/h} = 22 \text{ m/s}$$

$$F_x - F_R - mg \sin 10^\circ = 0$$

$$F_x = F_R + mg \sin 10^\circ$$

$$= 700 + 1400 \times 9.8 \times \sin 10^\circ$$

$$= 3100 \text{ N}$$

$$P = F_x v = 3100 \times 22 = 68000 \text{ (W)} = 68 \text{ (kW)}$$