Immersive VR: A Non-pharmacological Analgesic for Chronic Pain?

Diane Gromala, Ph.D

Simon Fraser University Surrey
250 -13450 102 Avenue
Surrey, BC V3T 0A3 CANADA
dgromala@sfu.ca

Steven J. Barnes, Ph.D

University of British Columbia
2136 West Mall
Vancouver, BC V6T 1Z4 CANADA
sjb@nervouscreation.com

Meehae Song

Simon Fraser University Surrey
250 -13450 102 Avenue
Surrey, BC V3T 0A3 CANADA
meehaes@sfu.ca

Mark Nazemi

Simon Fraser University Surrey
250 -13450 102 Avenue
Surrey, BC V3T 0A3 CANADA
mna31@sfu.ca

Ji-Dong Yim

Simon Fraser University Surrey
250 -13450 102 Avenue
Surrey, BC V3T 0A3 CANADA
jdyim@sfu.ca

Chris Shaw, Ph.D

Simon Fraser University Surrey
250 -13450 102 Avenue
Surrey, BC V3T 0A3 CANADA
shaw@sfu.ca

Tyler Fox

Simon Fraser University Surrey
250 -13450 102 Avenue
Surrey, BC V3T 0A3 CANADA
tfox@sfu.ca

Dr. Pam Squire, MD, CCFP

University of British Columbia
317 - 2194 Health Sciences Mall
Vancouver, BC V6T 1Z3 CANADA
ps@pamsquire.com

Copyright is held by the author/owner(s).

CHI 2011, May 7–12, 2011, Vancouver, BC, Canada.

ACM 978-1-4503-0268-5/11/05.

Abstract

This paper describes the research work being carried out by the Transforming Pain Research Group – the only group whose work is exclusively focused on the use of immersive VR for chronic pain management. Unlike VR research for acute or short-term pain, which relies on pain "distraction," this research posits a new paradigm for the use of VR. In addition to providing an overview of our work, the present paper also describes one of our current works in detail: the Virtual Meditative Walk.

Keywords

Immersive Virtual Reality, Virtual Environments, Mindfulness Meditation, Meditation, Biofeedback, Chronic Pain, Non-pharmacological Analgesia, Self-modulation

ACM Classification Keywords

H.5.1 Multimedia Information Systems: Artificial, augmented, and virtual realities.

General Terms

Design, Experimentation

Acute vs. Chronic Pain

Pain is considered to be one of two types: acute pain or chronic pain. Acute pain can usually be traced to some observable damage to a specific body part. Acute pain will usually resolve itself relatively quickly: when we cut our finger with a knife, we experience acute pain; but that pain will usually subside within minutes to hours.

In contrast, chronic pain lasts much longer than acute pain, and need not be associated with any observable bodily damage. Chronic pain persists well beyond the normal healing period might even persist for a lifetime. [8] Chronic pain might result from any one of many antecedents, including even a brief exposure to acute pain. However, a clear antecedent injury isn't necessarily a requirement for chronic pain, as neuropathic pain illustrates. In neuropathic pain, one common type of chronic pain, there is no evidence of nociceptor activation in association with the experience of pain [12]. Chronic pain is the pathological side of pain: it is pain without any clear protective purpose.

An estimated 15%-29% of the North American population currently suffers from chronic pain [1]. Decreases in mobility and social interaction are both common sequelae [11]. For example, we recently interviewed 20 senior citizens about how chronic pain impacted their lives, and found that their pain had the most serious impact on scheduled social activities. These impacts occurred most strongly when analgesic methods failed. We hope that the approach proposed here can add alternative analgesic avenues where others fail.

Virtual Reality for Acute Pain

Hoffman et al. [4] have convincingly shown that immersive virtual reality (VR) is effective for the treatment of acute

pain. There were two largely unexpected outcomes of Hoffman et al.'s ground breaking research: (1) In patients experiencing acute pain, the magnitude of VR-induced analgesia was shown to be comparable to that of opioids [4], and (2) there was no development of tolerance to the analgesic effects of VR on acute pain [5]. Tolerance is a big problem in opioid-based therapies. Acute pain has not been the only medical application of VR. Indeed, VR has been used effectively for a variety of medical applications ranging from post-stroke rehabilitation (e.g., [7]) to the treatment of phobias [2] and post traumatic stress disorder [3].

Virtual Reality for Chronic Pain?

Given the demonstrated ability of VR to serve as a powerful treatment for acute pain, can similar therapeutic benefits of VR be derived for individuals suffering from chronic pain? And, if so, would the approach to VR have to be fundamentally different from what has been used in VR-based therapies for acute pain? Although VR does work for the treatment of acute pain, there is no guarantee that it would also do so for its pathological counterpart, chronic pain. Chronic pain is a medical condition with a complex etiology and idiosyncratic presentation that require a fundamentally different approach to VR development.

Dr. Diane Gromala recently formed a multidisciplinary research group composed of a medical practitioner, a neuroscientist, psychologists, computer scientists, an engineer and artists. As the Transforming Pain Research Group, we are involved in several large projects that collectively seek to help individuals living with chronic pain deal with the various aspects of their illness.

One of our major areas of concern has been to address the question of whether VR can be developed as a therapeutic

application for chronic pain. To that end, a major focus of our group has been on the development of VR treatments that build on and integrate what we already know can be effective for the management of chronic pain. One line of research is the investigation of the utility of VR-based biofeedback and meditative practices, since these interventions have consistently been shown effective for improving major aspects of functioning in sufferers of chronic pain (e.g., [6]). In their Meditation Chamber, Shaw, Gromala, and colleagues [9,10] demonstrated that biofeedback and VR can be effectively combined to accelerate the adoption of a meditative practice. More specifically, they showed that VR can enhance a user's ability to enter a meditative state and to effectively use biofeedback. Based on that foundational work, we are now creating a VR-based therapy for chronic pain that incorporates a unique virtual environment (VE) with biofeedback and meditation.



figure 1. Immesant Meditating in the Meditation Chamber

Virtual Meditative Walk

The VE that we are building engages the participant in a walking mediation. We chose a walking form of meditation

because we wanted to directly address the decreases in mobility that are known to accompany chronic pain, while simultaneously using our VE to augment meditative training and encourage the adoption of a long-term mindfulness meditative practice.

This new work-in-progress, the *Virtual Meditative Walk*, incorporates a unidirectional treadmill. The speed of the users' ambulation on that treadmill is recorded and serves as the primary input that drives the navigation of the user's avatar through the VE. In short, ambulation on the treadmill leads to a forward motion through the VE. In addition, the physiological data that are recorded from the participant and fed into the system affect various visual and sonic aspects of the virtual landscape. That is, as the meditator becomes increasingly relaxed and begins to display physiological characteristics indicative of a meditative state, they are given feedback about their successes via visual and sonic changes within the VE.

Figure 2 illustrates the general overview of the VR system for the *Virtual Meditative Walk*. To experience the VE, a participant must first be attached to one or more biofeedback devices, be positioned on a treadmill and don the head-mounted display (HMD). The system is also capable of providing output to observers (e.g., researchers, physicians) about the individual's performance in terms of their biofeedback variables, ambulation speed, etc.

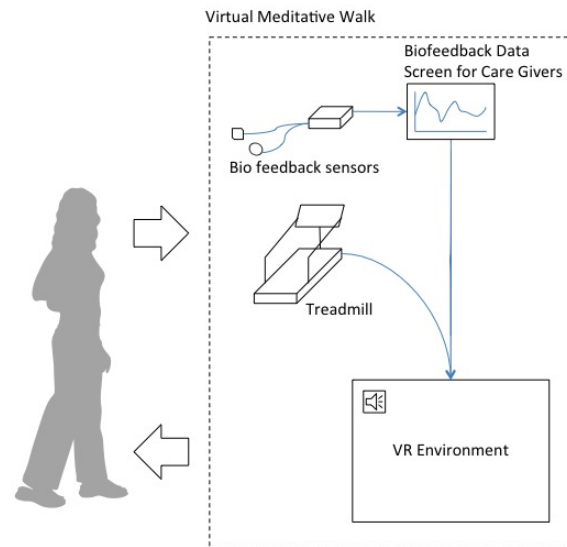

figure 2. Overall Structure of the System for the *Virtual Meditative Walk*

Figure 3 provides a more detailed illustration of the *Virtual Meditative Walk* system architecture. Biofeedback signals recorded by Thought Technology's ProComp+ device are sent through a client to Thought Technology's Connection Instrument (i.e., a specialized socket server). These data are subsequently passed into 3DVIA's Virtools application where those data have a real-time effect on the VE content that is currently being rendered by Virtools.

Velocity data are collected from the treadmill via an optical sensor positioned on the surface of the treadmill such that it can register any ambulation by the participant. Those treadmill data are also fed into

3DVIA's Virtools where they affect the translation of the camera within the VE. This causes the user's avatar to either move forwards or backwards at various speeds as a function of the immersant's direction and velocity of ambulation.

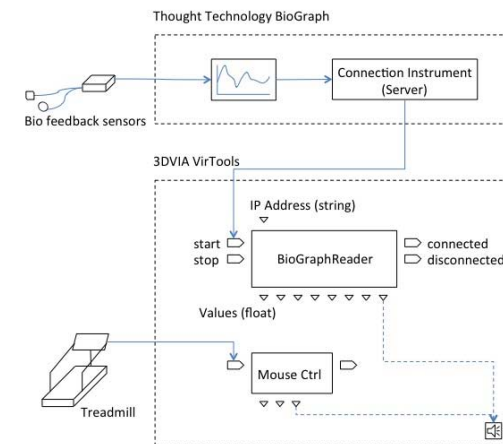

figure 3. Detailed System Architecture of the *Virtual Meditative Walk*

We have arranged to conduct user studies on our *Virtual Meditative Walk* in the Fall of 2011. Participants with chronic pain have been recruited from a pain clinic in Vancouver, Canada and testing will occur in a quiet room in that clinic.



figure 4. The Virtual Meditative Walk

Discussion

For the past 15 years, research on VR for pain has focused almost exclusively on therapies for acute pain. Our group's focus on VR for the management of chronic pain is both novel and necessary—developing therapies for such a complex disorder requires a fundamentally different approach to VR development.

Although the exact mechanism of VR's effectiveness for acute pain is unknown, current speculation has settled around the idea that it serves as a form of "distraction." If true, this further underscores the strong need for a fundamentally different approach to the development of VR-based therapies for chronic pain. Why? Simply because you can only distract a person for so long, and we also can't expect a person with chronic pain to wear a head mounted display for every waking hour of their life. Thus, our multidisciplinary approach aligns well with the unique etiology and phenomenology of chronic pain.

Based on our consultation with several well-known Canadian pain experts, we have adopted an approach to the development of a VR-based therapy for chronic pain that builds on those behavioral manipulations that we already know to be effective for the management of chronic pain: biofeedback and mindfulness meditation.

This fall we will be conducting user studies with chronic pain sufferers in a pain clinic. Based on the outcomes of those studies and other questionnaire-based studies, we plan to develop a relatively low-cost turnkey system. This will allow the *Virtual Meditative Walk* to be employed more widely than in just one complex pain clinic. Ideally, once such a turnkey system is built, our hope is to see it being widely used in pain clinics and hospitals—giving another tool to physicians and patients trying to deal with chronic pain.

Acknowledgements

The Transforming Pain Research Group is supported by the Canadian Research Chairs Program, National Centres for Excellence GRAND, Social Sciences and Humanities Research Council, the Michael G. DeGroot National Pain Centre, Thought Technologies and FirstHand Technology.

References

- [1] Boulanger, A., Clark, A. J., Squire, P., Cui, E., & Horbay, G. L. A. Chronic pain in Canada: Have we improved our management of chronic noncancer pain? *Pain Research and Management* 12 (2007), 39-47.
- [2] Brinkman, W. van der Mast, C., & de Vliegher, D. (2008). Virtual reality exposure therapy for social phobia: A pilot study in evoking fear in a virtual world. In *Proc. HCI 2008 Workshop* (2008), 29-35.
- [3] Emmelkamp, P. Post-traumatic stress disorder: Assessment and follow-up. In M.J. Roy (Ed.) *Novel approaches to the diagnosis and treatment of posttraumatic stress disorder*, IOS Press (2006), 309-320.
- [4] Hoffman, H. G., Richards, T. L., Van Oostrom, T., Coda, B. A., Jensen, M. P., Blough, D. K., Sharar, S.R. The analgesic effects of opioids and immersive virtual reality distraction: evidence from subjective and functional brain imaging assessments. *Anesthesia and Analgesia* 105 (2007), 1776-1783.
- [5] Hoffman, H. G., Patterson, D. R., Carrougher, G. J., & Sharar, S. R. Effectiveness of virtual reality-based pain control with multiple treatments. *Clinical Journal of Pain* 17 (2001), 229-235.
- [6] Morone, N. E., Greco, C. M., & Weiner, D. K. Mindfulness meditation for the treatment of chronic low back pain in older adults: A randomized controlled pilot study. *Pain* 134 (2008), 310-319.
- [7] O'Dell, M. W., Lin, C-C. D., & Harrison, V. Stroke rehabilitation: Strategies to enhance motor recovery. *Annual Review of Medicine* 60 (2009), 55-68.
- [8] Russo, C. & Brose, W. Chronic pain. *Annual Review of Medicine* 49 (1998), 123-133.
- [9] Shaw, C., Gromala, D., & Fleming Seay, A. The Meditation Chamber: Enacting autonomic senses. In *Proc. of ENACTIVE/07* (2007), 405-408.
- [10] Shaw, C., Gromala, D., & Song, M. (in press) The Meditation Chamber: Towards Self-modulation. G. Mura, (Ed.) in *Metaplasticity in Virtual Worlds: Aesthetics and Semantics Concepts* (2011), IGI Publishing.
- [11] Statistics Canada (2008). Study: Chronic pain in Canadian seniors <http://www.statcan.gc.ca/daily-quotidien/080221/dq080221b-eng.htm>. Retrieved July 15, 2010.
- [12] Treede, R-D., Jensen, T.S., Campbell, J.N., Cruccu, G., Dostrovsky, J.O., Griffin, J.W., Hansson, P., Hughes, R., Nurmikko, T., & Serra, J. Neuropathic pain: Redefinition and a grading system for clinical and research purposes. *Neurology* 70 (2008), 1630-1635.