

The Negation Operator

Linguistics 322

Intermediate Syntax

1. Introduction

Negation of simple clauses is formed with the negative particle not. There are two kinds of negation: simple sentence negation and contrastive negation.

Let us start with sentence negation. At S-structure the negative particle is adjoined to the first auxiliary verb in the clause:

- (1) a. Mary went to the movies.
b. Mary did not go to the movies.

Negation is an operator. Its function is to claim that the proposition it modifies is false. In (2), for example, the speaker is claiming that the proposition that Mary went to the movies is false. In the logical system developed here, Neg is an operator forming a Neg-proposition with its argument an M-proposition:

- (2) **Expansion of the Negative Proposition**
Neg-Proposition --> [NEG] <M-proposition>.

In the first pass to the lexicon [NEG] is bound and weak. It's host is T:

Table 1: Lexical Entry of Not

Properties	
not	orthographic form
+Bound, _Weak, T+_____	features
NEG	Conceptual Form

Following a binary analysis, NEG contains the feature [+Neg]. [+Neg] is negative, while [-Neg] is positive. It is almost always empty phonetically. When two people are having a disagreement, one may say:

(3) I think not.

And the other one may reply:

(4) I think so.

It appears that so may be the positive marker. If so, it is the only case I can think of in English where [-Neg] has a phonetic form. o that (5) I think not does not means the same thing as I don't think. Not in (5) is negating the understood complement which is empty here.

The logical structure of (1b) is the following:

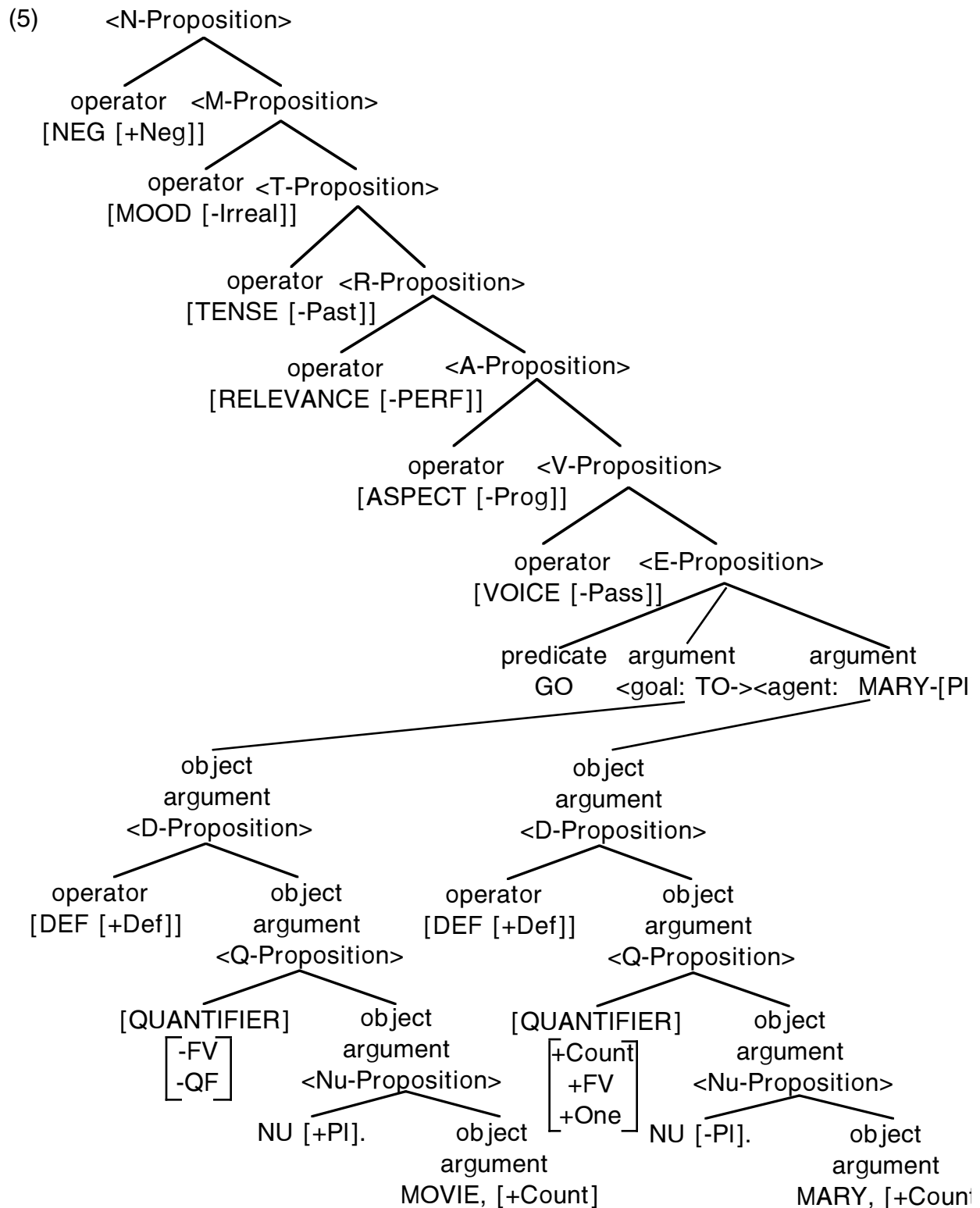

Negation is a weak operator in that it does not trigger movement. The S-structure for (2) is the following:

The S-structure for the first clause in (3) is the following:

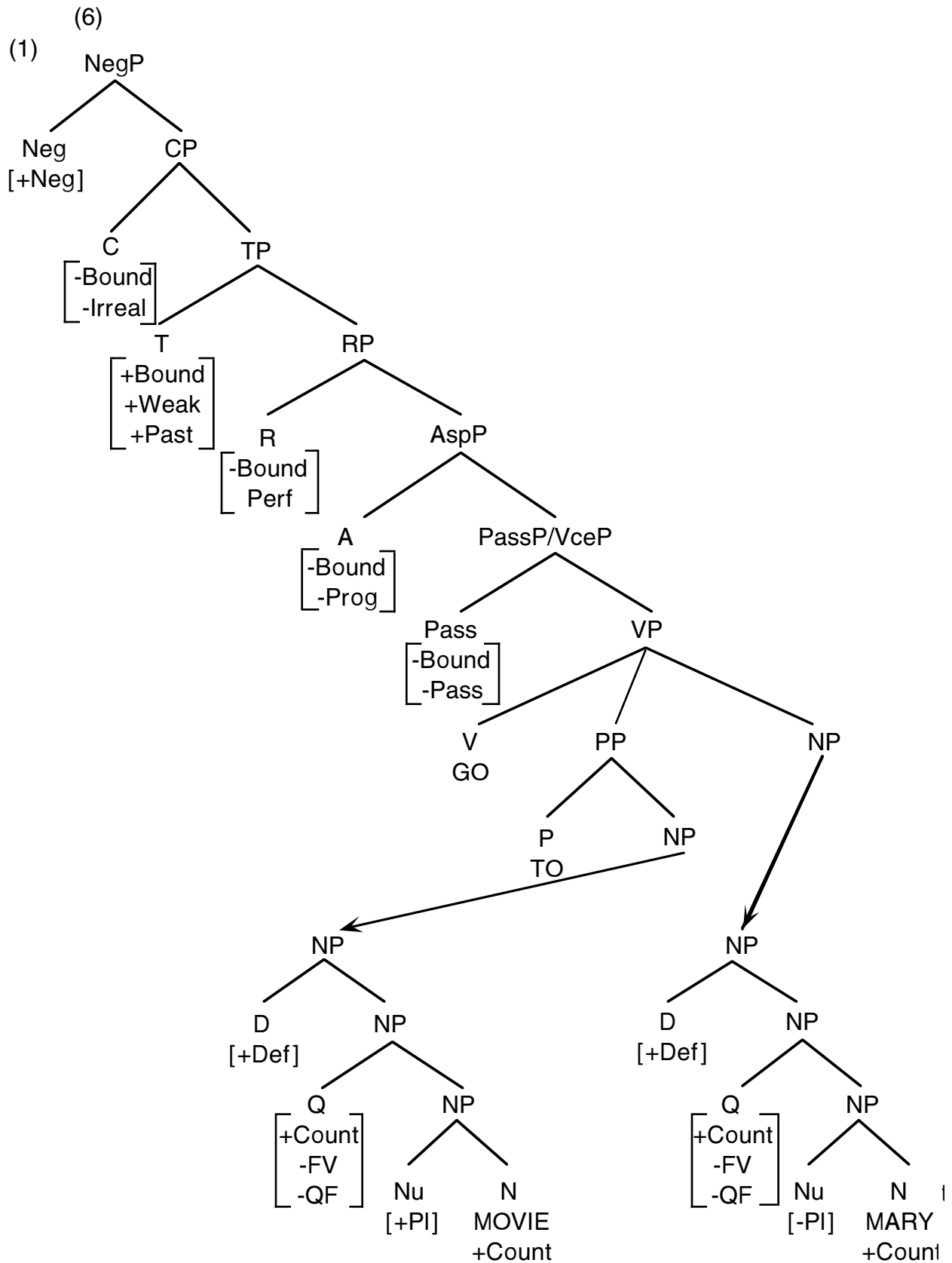

Why is Neg adjoined to T. The only answer at this time is that English evolved in such a way that T became the host for the sentential negative particle ([_{Neg} not]. If Neg is generated at D-structure adjoined to V, then there can be no explanation accounting for its position. There is reason to believe that operators form heads of projections as we have seen. Suppose we assume that there is a projection of Neg dominated by NegP, the position of the N-proposition. NegP now dominates CP which in turn dominates TP:

(7) **Hierarchy of NegP**

NegP > CP > TP > RP > AspP > VceP > VP.

There may be a semantic explanation for this hierarchy as must be the case for NegP, since it must take scope over the sentence it negating.

In the first pass to the lexicon we find out that Neg is bound and weak and is marked for the host T. We will formally distinguish between clausal negation and contrastive negation with the feature [\pm Contrastive]:

Table 2: Grammatical Entry of Not

[+Neg]	Conceptual feature
Neg	category
Clitic	morpheme type
+Bound	inherent feature
+Weak	inherent feature
T+_____	inherent feature
not, n't	orthographic form

Any declarative statement that we make can be affirmative (unmarked normally) or negative (usually marked with Neg). If (5) is correct, then Neg originates in NegP and then it must lower to the verb. Neg is a weak particle which means that it cannot stand alone unless the remainder of the sentence is omitted:

(8) I guess not.

Here, not is the only form left after the remainder of the sentence is omitted:

(9) I guess [not [that he is coming]].

If the argument of not is not omitted, then not must lower:

- (10) I guess [[that he is not coming]].

It is a parameter of English that the only acceptable host for the particle Neg can be an inflected auxiliary (strong) verb. This explains why not does not lower to NP (Mary). It cannot lower to go because go is neither an auxiliary verb nor is it inflected here. If there is no auxiliary verb, Neg cannot lower to the main verb:

- (11) *Mary went not to the movies.

The functional (dummy) auxiliary verb do must be inserted to function as a host for tense which licenses Neg:

- (12) Mary did not go to the movies.

The infinitive provides some further evidence. The negative particle cannot lower to the uninflected auxiliary (or a the main verb) in an infinitival clause:

- (13) a. To have been loved or not to have been loved is the question.
b. *To have been loved or to have not been loved is the question.

Although the negative particle is adjoined to the inflected word, it is tense that licenses the lowered negative particle. Not is strong only when it cannot lower. The strengthening of not is a last resort.

The lowering of Neg to T brings up a new problem. Although Neg is adjoined to T, it does not form the same kind of bond with T that an inflectional does. First note that not is spelled as a separate word whereas inflectional endings never are:

- (14) a. John did not go.
b. Mary has not gone.

The difference appears to be in the kind of boundary between T and Neg. It is stronger than the morpheme boundary. The symbol '#' is often used to mark this boundary, indicating a word boundary. But we emphasize here that '#' marks adjunction. '##' is used to mark independent words as if we were to rewrite (14) with boundaries:

- (15) a. John##did#not##go.
b. Mary##has#not##gone.

Normally, only one word in the X#Y construction can be stressed. However, the second word can be stressed in an emphatic context:

(16) John díd nót go.

The next question is how to represent this structurally. This seems not to be a structural problem but one of morphology and word concatenation. Looking at some other languages, the agreement inflectional morphemes are the periphery of inflection, and if anything is adjoined to the word containing agreement morphemes, the bond is weaker--that is it is '#'. Unless it becomes absolutely necessary to mark it, we shall defer this question for now.

As we mentioned above Neg blocks the lowering of T. Neg, however, remains strong. It does not raise to Neg in the syntax:

- (17) a. *John reads not books.
b. *Not John reads books.

The hostless T must wait until the second pass to the lexicon where the appropriate dummy verb is selected. If T is a sister to a main verb, {DO} is selected:

(18) John does not read books.

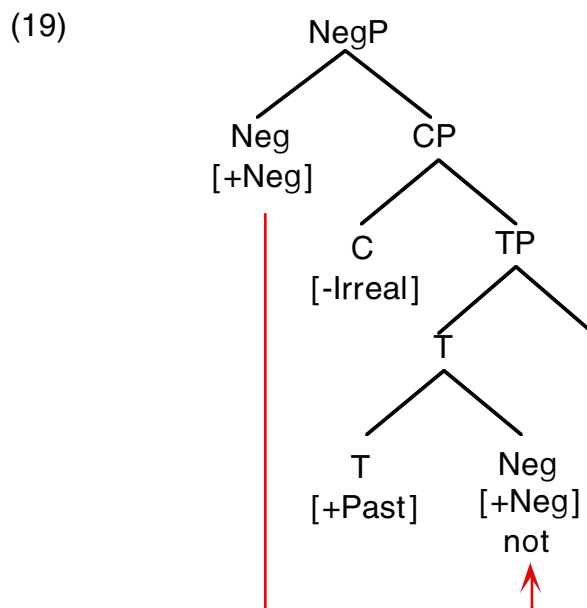

The complete structure after the lowering of Neg is:

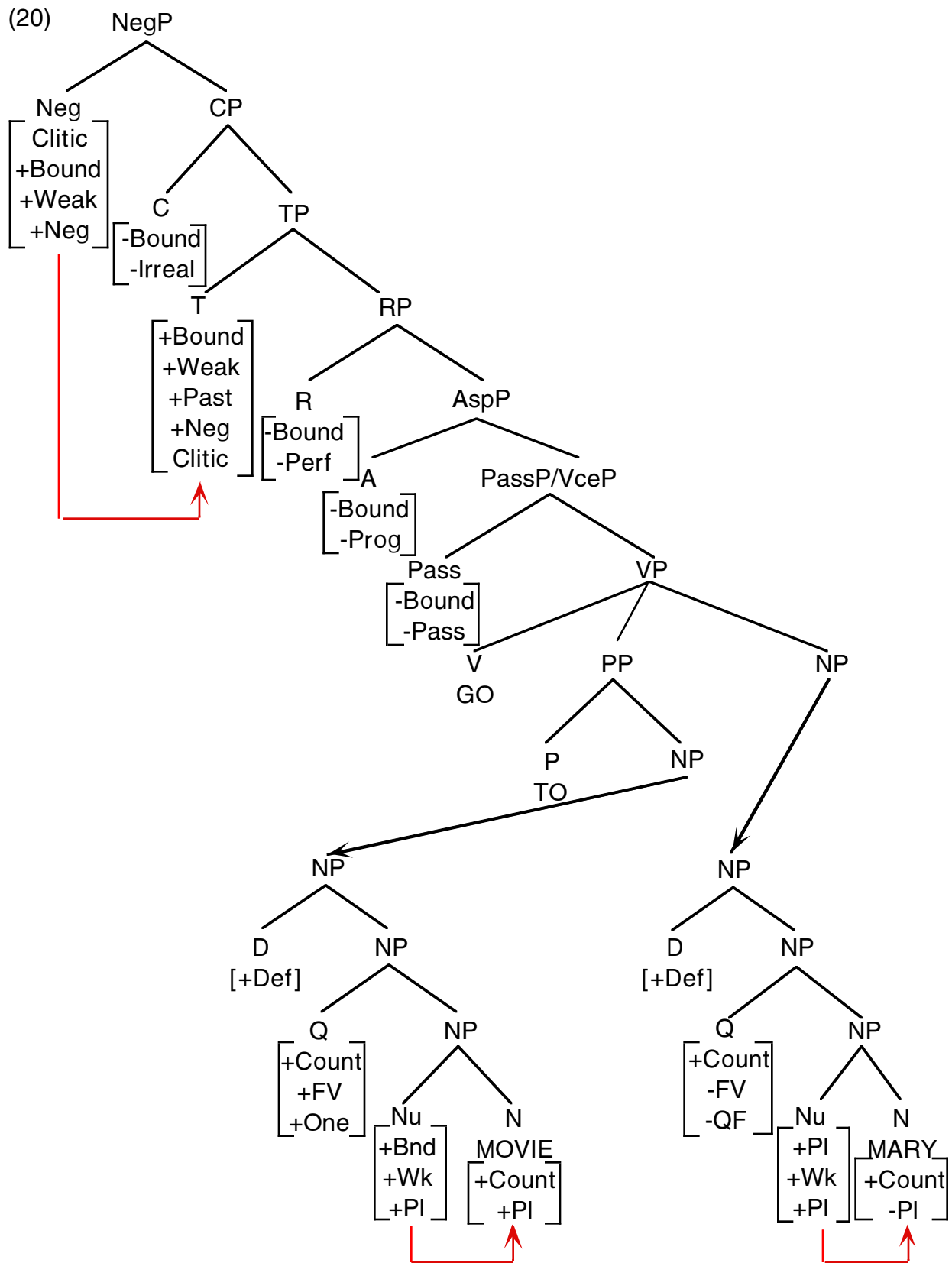

The feature clitic means that the features associated with it are realized as a distinct clitic form in the syntax. T, then, splits into T plus Neg. The agent raises in search for Case:

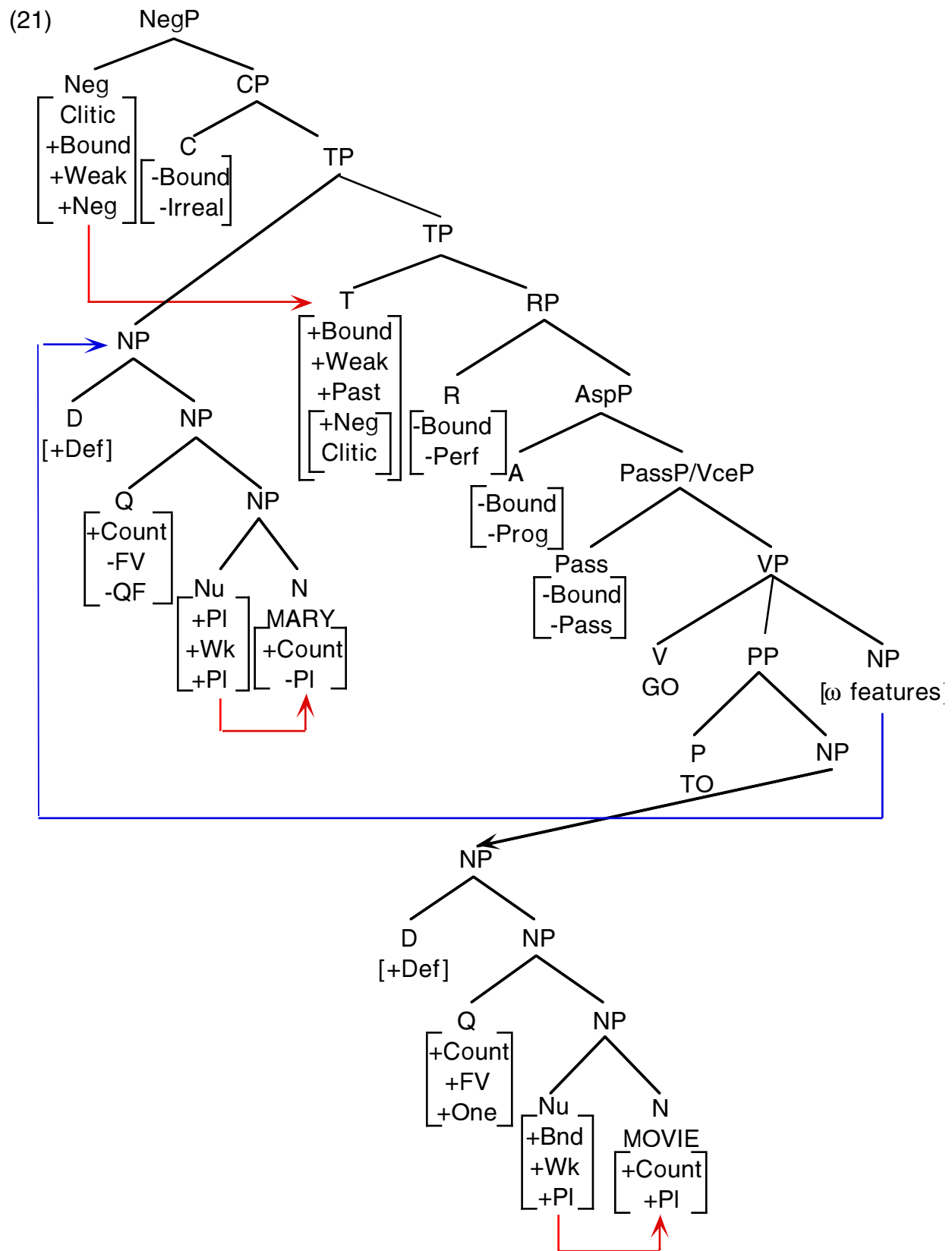

In the second pass to the lexicon, the bound features are spelled out as [EMPTY], {do} is inserted, {do}+[+Past] is spelled out as di+d, Neg as not, TO as to, [+Def] as [EMPTY] preceding Mary and as the preceding movies, MARY as Mary MOVIE+[+PI] as movie+s:

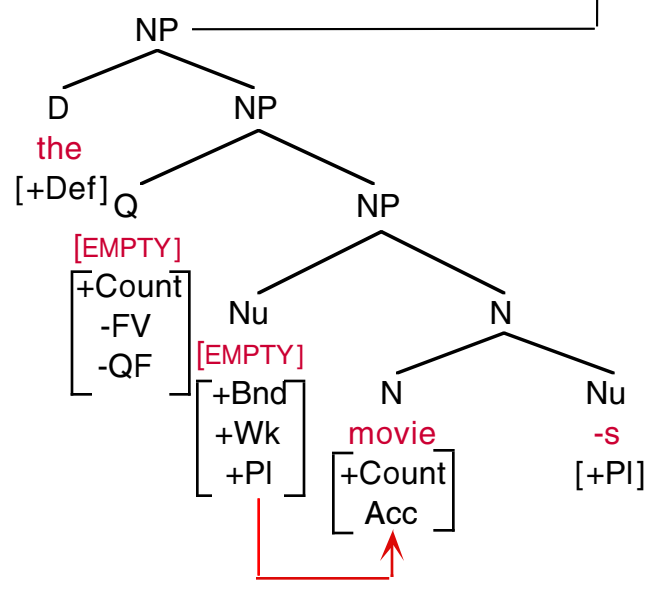
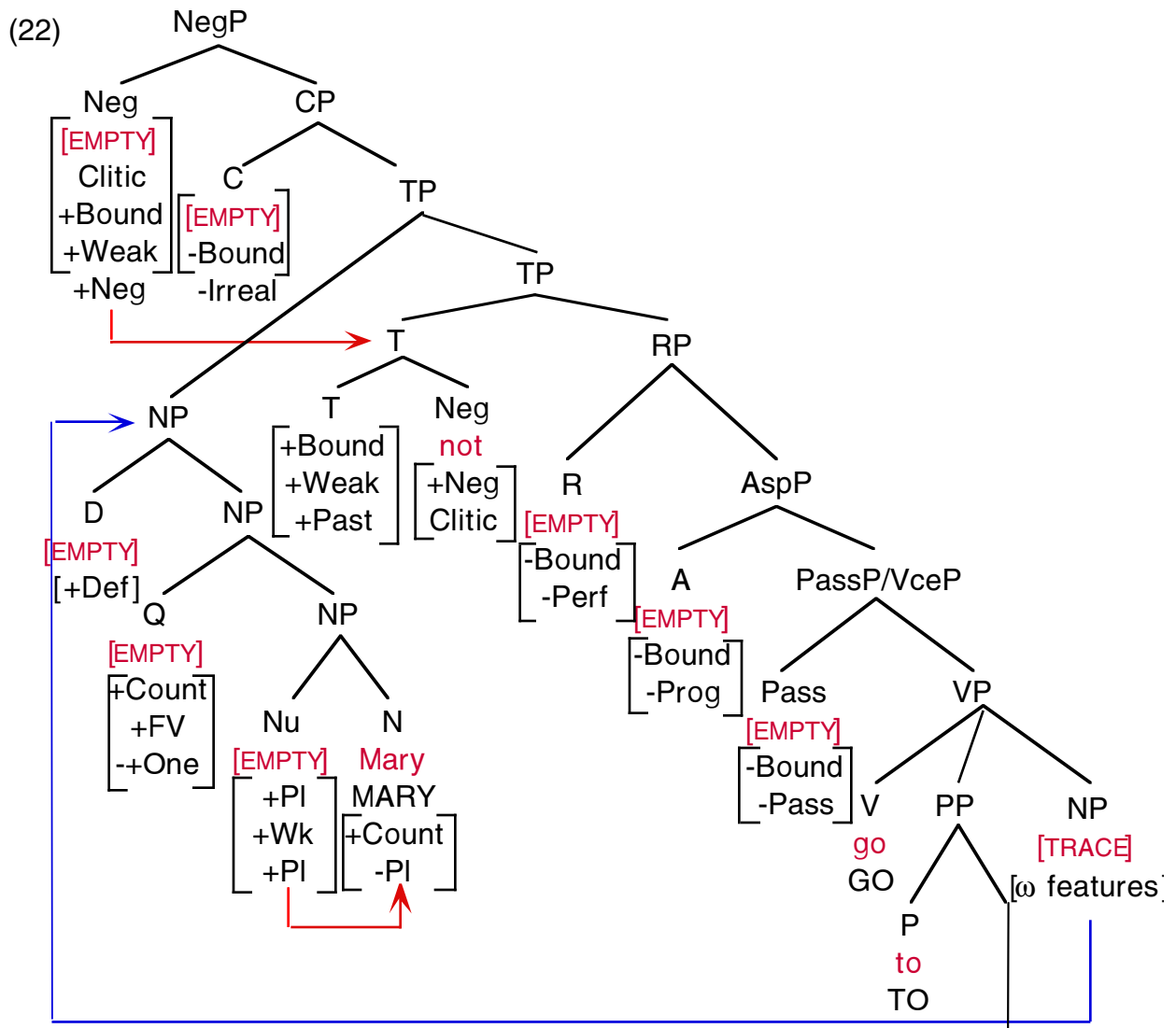

2. Contrastive Negation

Contrastive negation is where any node (phrasal node?) is the complement of not, and the negated phrase is conjoined to a positive phrase by the conjunction but. Not is a word, Neg, and c-commands the phrase that it takes scope over:

- (23) a. Mary may go not to the movies but to a play.
 b. Mary may go [not to the movies] but to a play.

Here, the PP is contrastively negated. Although traditional grammar. The string not to the movies but to a play forms a constituent as evidence in preposing:

- (24) a. Not to the movies but to a play did Mary go.
 b. *Not to the movies did Mary go but to a play.

To go to theta roles [click here](#).

To return to course outline [Click here](#).