

# Chapter 6

## The Link Layer and LANs

A note on the use of these PowerPoint slides:

We're making these slides freely available to all (faculty, students, readers). They're in PowerPoint form so you see the animations; and can add, modify, and delete slides (including this one) and slide content to suit your needs. They obviously represent a *lot* of work on our part.

In return for use, we only ask the following:

- If you use these slides (e.g., in a class) that you mention their source (after all, we'd like people to use our book!)
- If you post any slides on a www site, that you note that they are adapted from (or perhaps identical to) our slides, and note our copyright of this material.

For a revision history, see the slide note for this page.

Thanks and enjoy! JFK/KWR

All material copyright 1996-2025  
J.F Kurose and K.W. Ross, All Rights Reserved

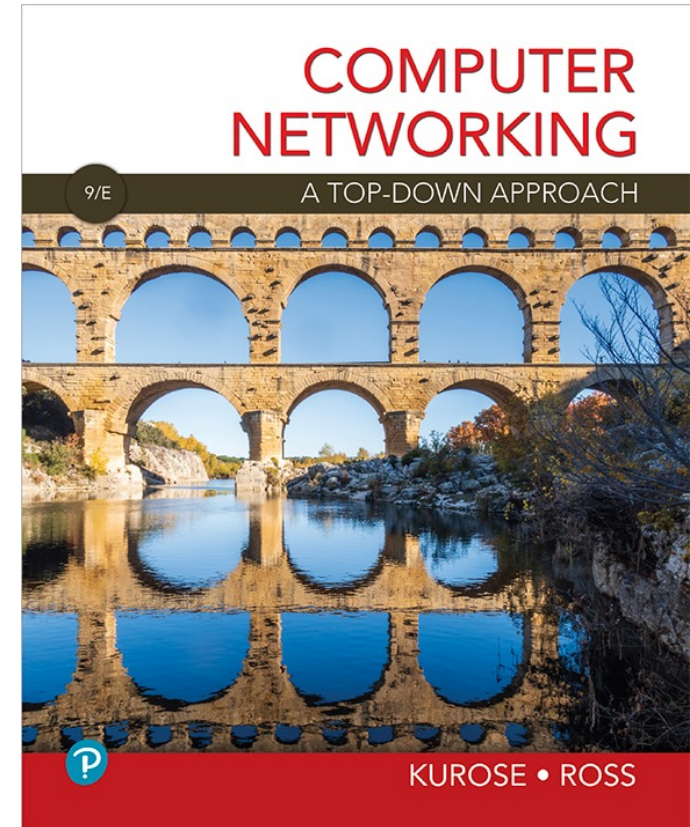

## *Computer Networking: A Top-Down Approach*

9<sup>th</sup> edition

Jim Kurose, Keith Ross  
Pearson, 2025

# Link layer and LANs: our goals

- understand principles behind link layer services:
  - error detection, correction
  - sharing a broadcast channel: multiple access
  - link layer addressing
  - local area networks: Ethernet, VLANs
- datacenter networks
- instantiation, implementation of various link layer technologies



# Link layer, LANs: roadmap

- **introduction**
- error detection, correction
- multiple access protocols
- LANs
  - addressing, ARP
  - Ethernet
  - switches
  - VLANs
- link virtualization: MPLS
- data center networking



- a day in the life of a web request

# Link layer: introduction

terminology:

- hosts, routers: **nodes**
- communication channels that connect **adjacent** nodes along communication path: **links**
  - wired , wireless
  - LANs
- layer-2 packet: **frame**, encapsulates datagram

*link layer has responsibility of transferring datagram from one node to **physically adjacent** node over a link*

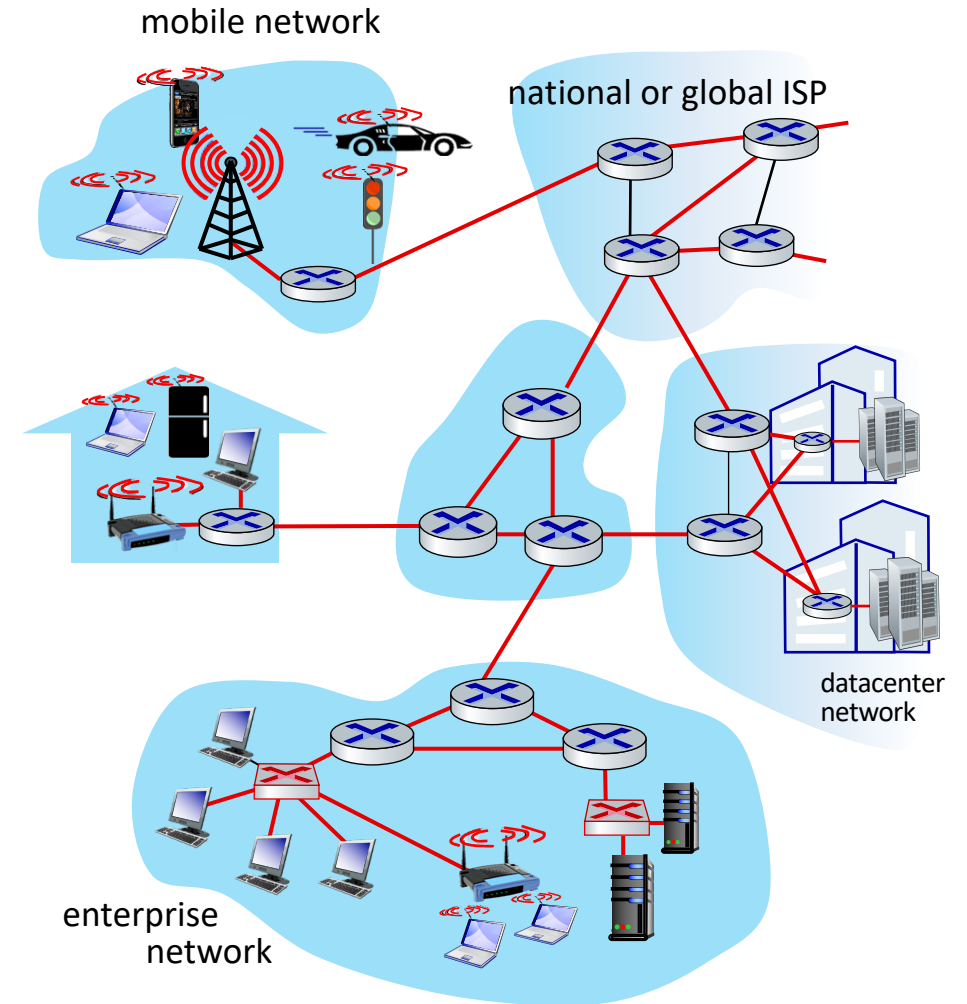

# Link layer: context

- datagram transferred by **different link protocols** over different links:
  - e.g., WiFi on first link, Ethernet on next link
- each link protocol provides different services
  - e.g., **may or may not** provide reliable data transfer over link

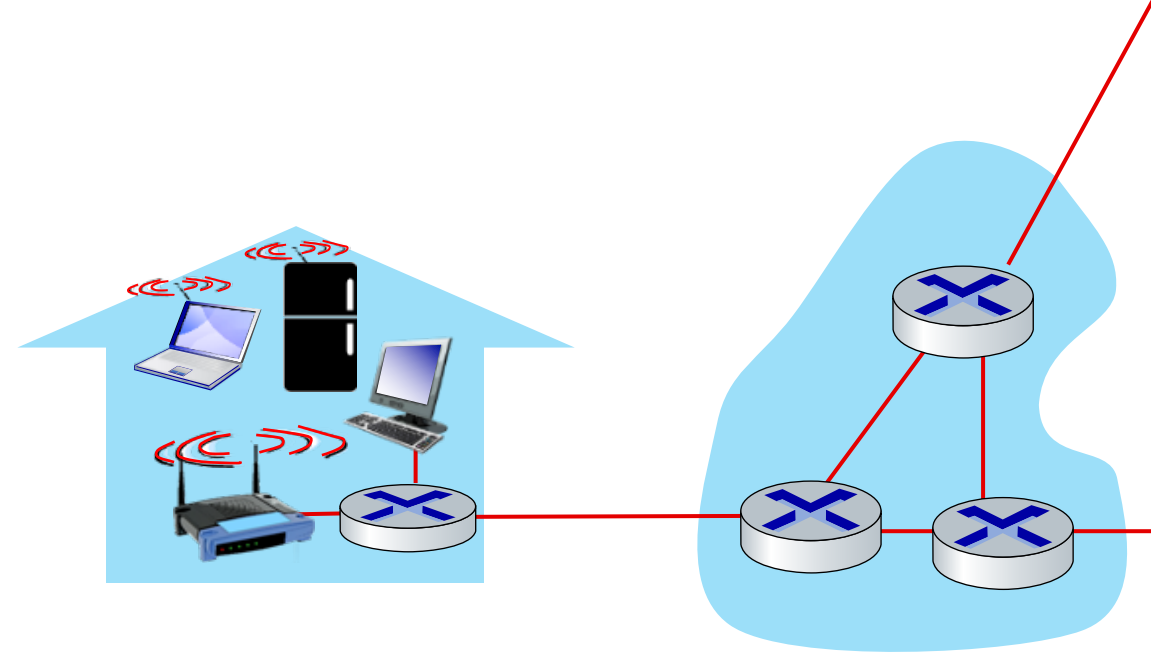

# Transportation analogy

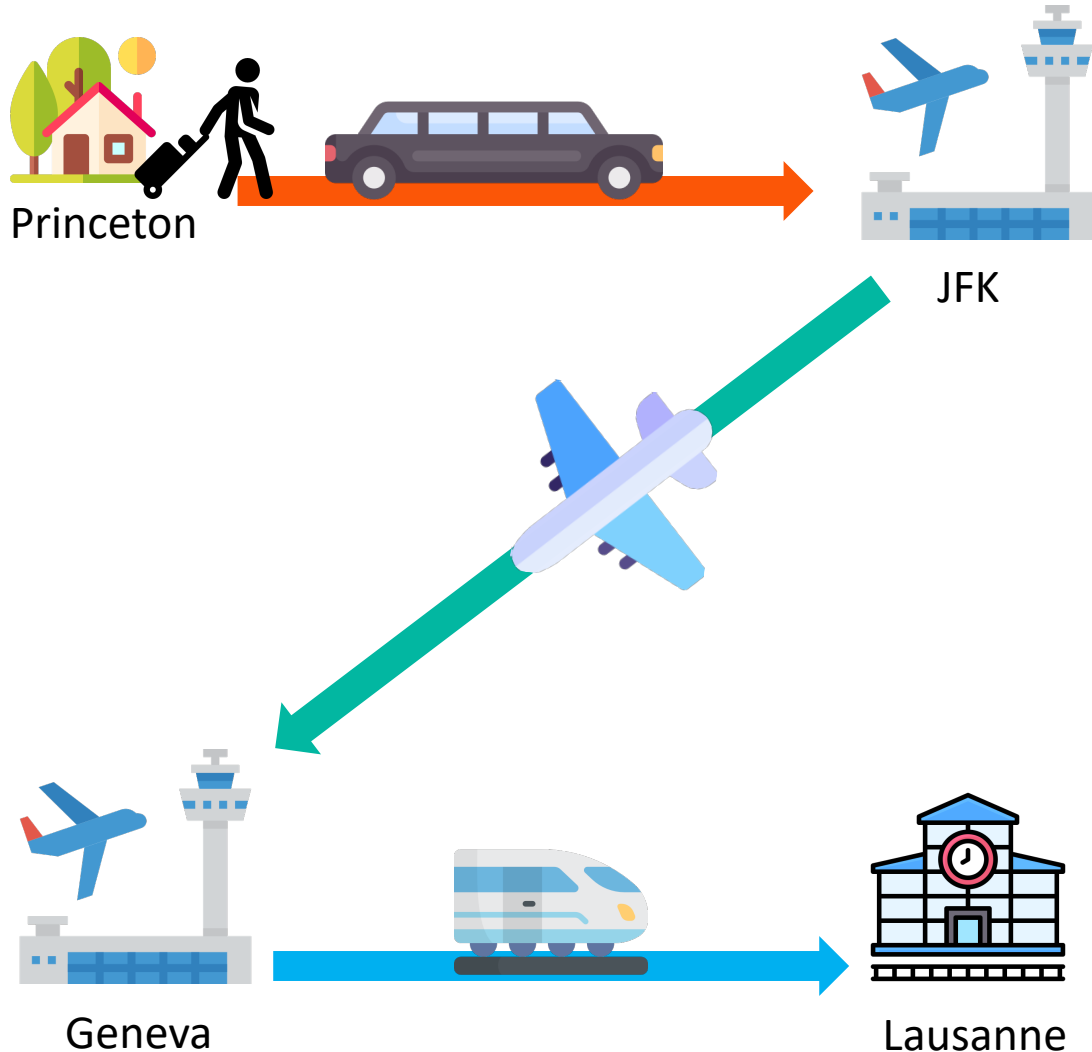

## transportation analogy:

- trip from Princeton to Lausanne
  - limo: Princeton to JFK
  - plane: JFK to Geneva
  - train: Geneva to Lausanne
- tourist = datagram
- transport segment = communication link
- transportation mode = link-layer protocol
- travel agent = routing algorithm

# Link layer: services

## ■ framing, link access:

- encapsulate datagram into frame, adding header, trailer
- channel access if shared medium
- “MAC” addresses in frame headers identify source, destination (different from IP address!)

## ■ reliable delivery between adjacent nodes

- we already know how to do this!
- seldom used on low bit-error links
- wireless links: high error rates
  - **Q: why both link-level and end-end reliability?**

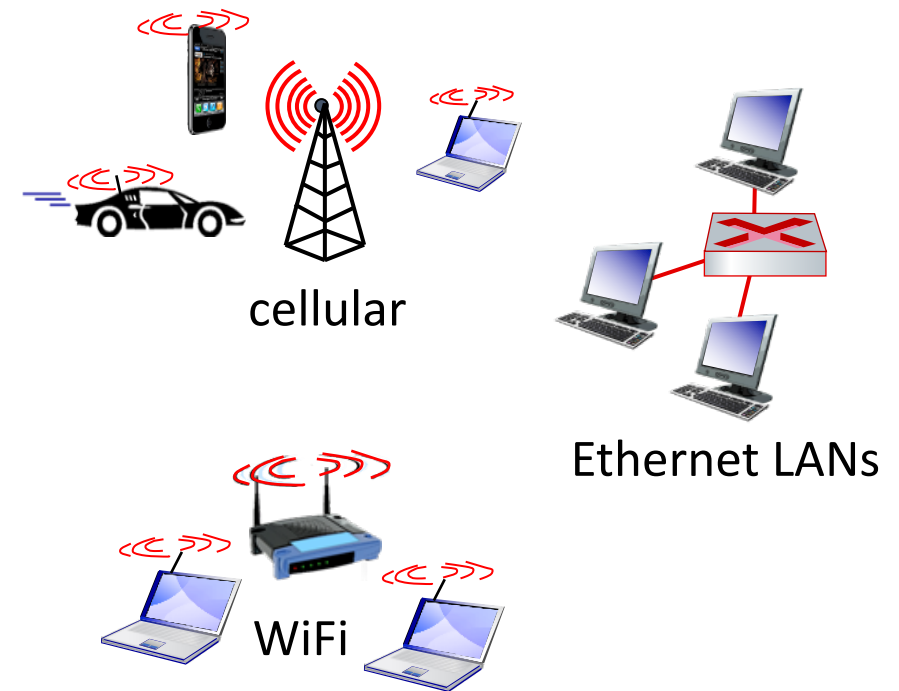
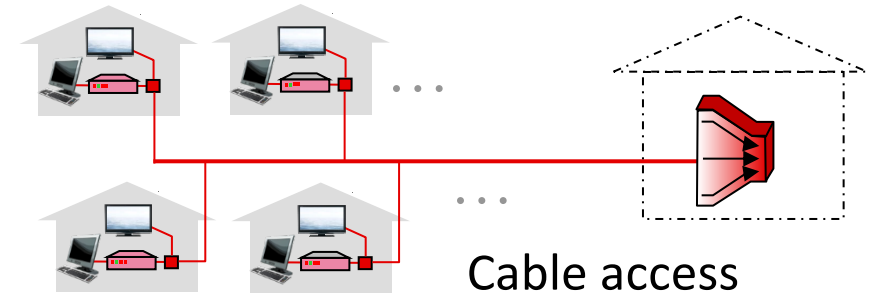

# Link layer: services (more)

- **flow control:**

- pacing between adjacent sending and receiving nodes

- **error detection:**

- errors caused by signal attenuation, noise.
- receiver detects errors, signals retransmission, or drops frame

- **error correction:**

- receiver identifies *and corrects* bit error(s) without retransmission

- **half-duplex and full-duplex:**

- with half duplex, nodes at both ends of link can transmit, but not at same time

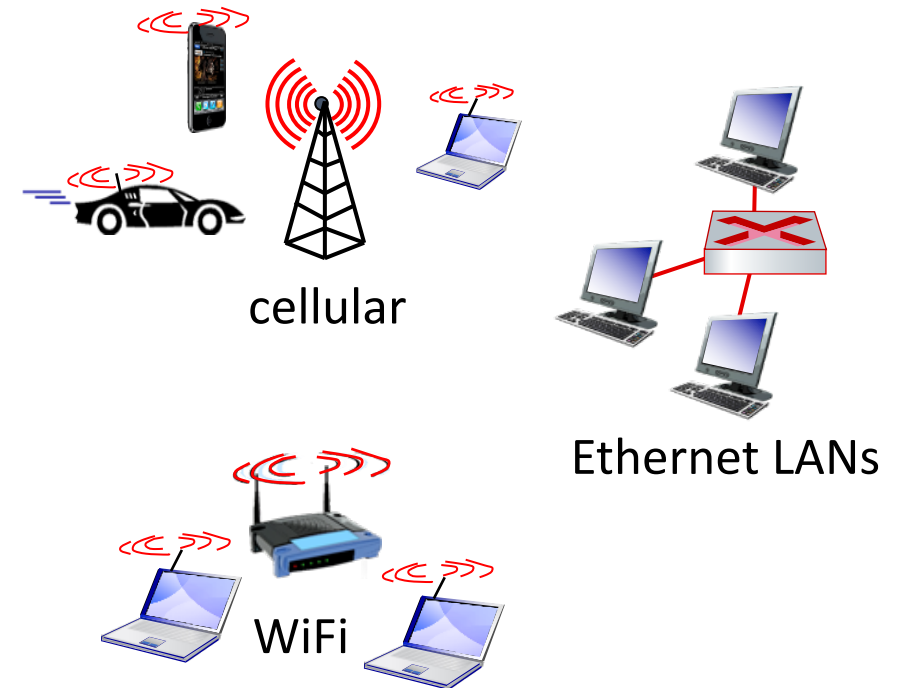
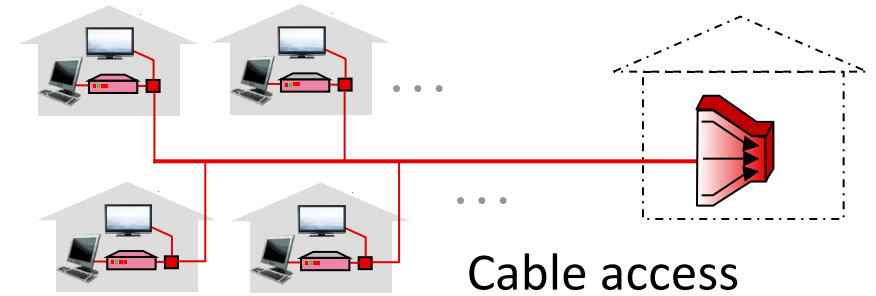

# Host link-layer implementation

- in each-and-every host
- link layer implemented on-chip or in network interface card (NIC)
  - implements link, physical layer
- attaches into host's system buses
- combination of hardware, software, firmware

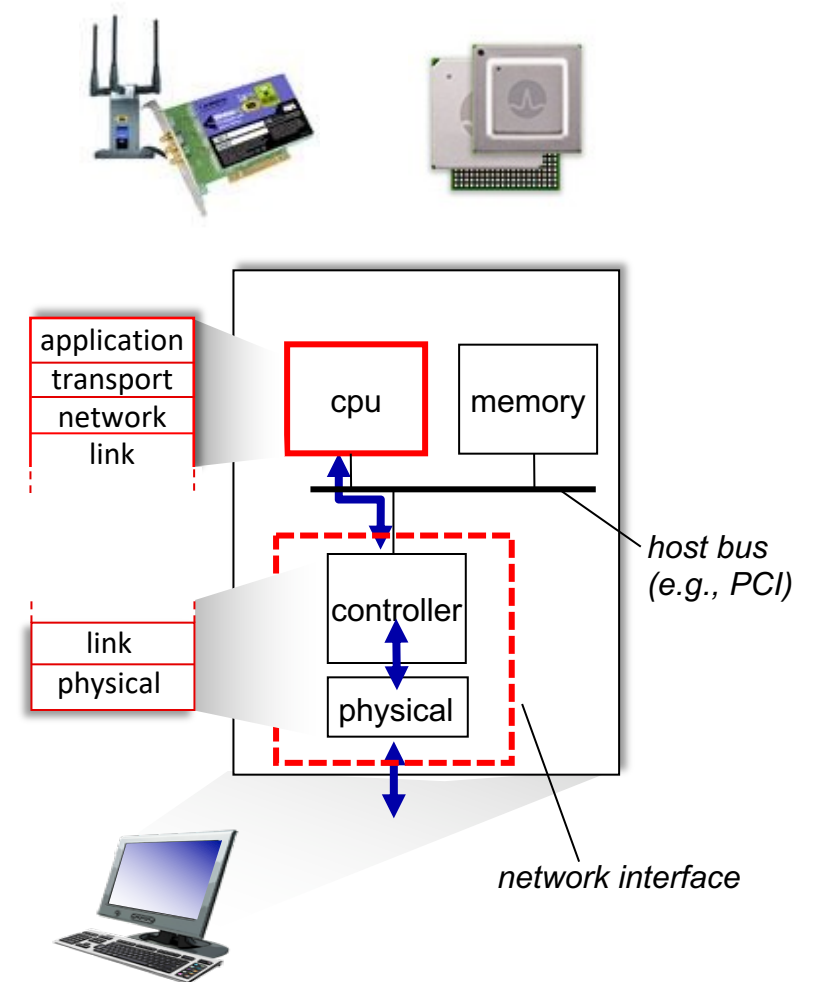

# Interfaces communicating

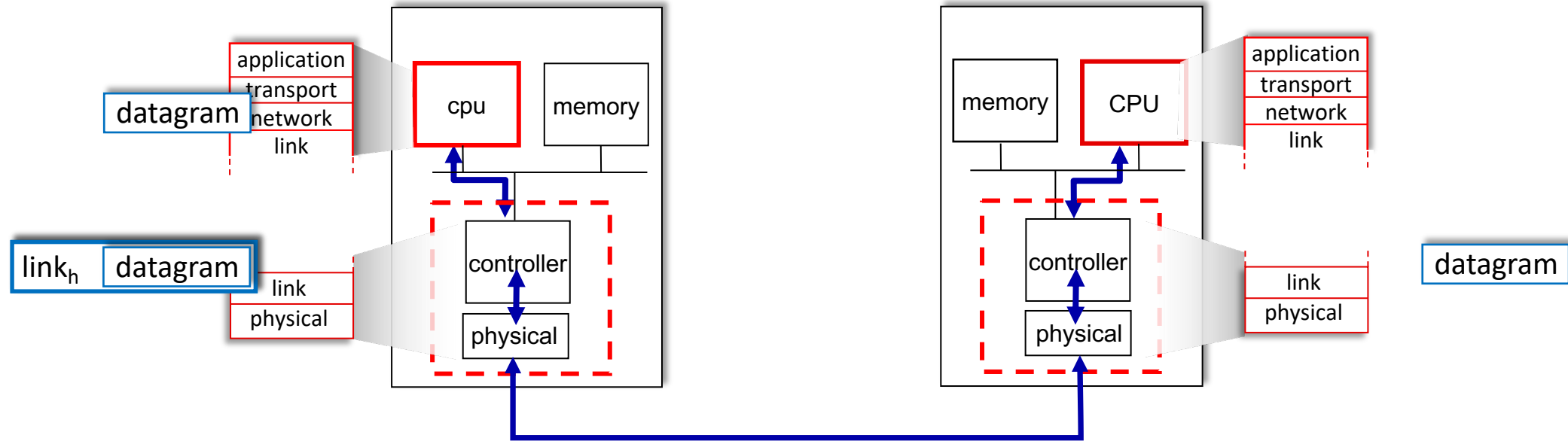

sending side:

- encapsulates datagram in frame
- adds error checking bits, reliable data transfer, flow control, etc.

receiving side:

- looks for errors, reliable data transfer, flow control, etc.
- extracts datagram, passes to upper layer at receiving side

# Link layer, LANs: roadmap

- introduction
- **error detection, correction**
- multiple access protocols
- LANs
  - addressing, ARP
  - Ethernet
  - switches
  - VLANs
- link virtualization: MPLS
- data center networking



- a day in the life of a web request

# Error detection

EDC: error detection and correction bits (e.g., redundancy)

D: data protected by error checking, may include header fields

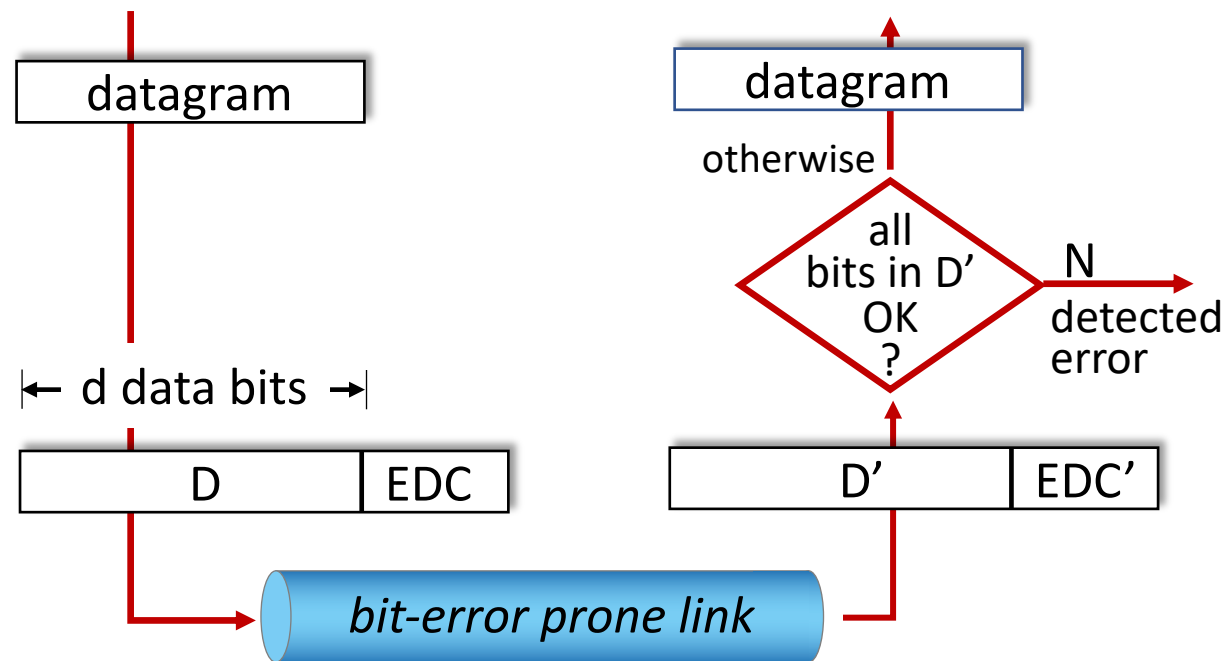

Error detection not 100% reliable!

- protocol may miss some errors, but rarely
- larger EDC field yields better detection and correction

# Parity checking

## single bit parity:

- detect single bit errors

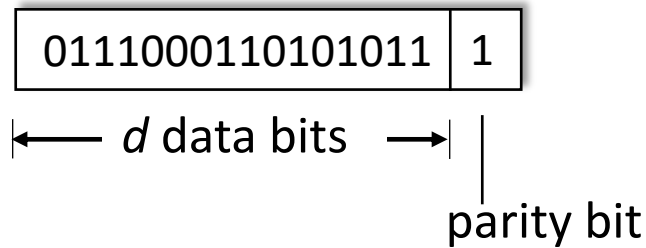

Even/odd parity: set parity bit so there is an even/odd number of 1's

## At receiver:

- compute parity of  $d$  received bits
- compare with received parity bit – if different than error detected



Can detect *and* correct errors (without retransmission!)

- two-dimensional parity: detect *and correct* single bit errors

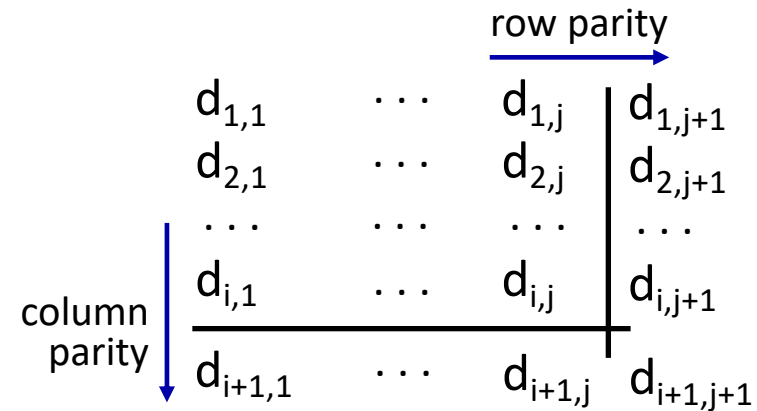

no errors:  
(even parity)

1	0	1	0	1	1
1	1	1	1	0	0
0	1	1	1	0	1
0	0	1	0	1	0

detected  
and  
correctable  
single-bit  
error:

1	0	1	0	1	1
<del>1</del>	<del>0</del>	<del>1</del>	<del>1</del>	<del>0</del>	<del>0</del>
0	1	1	1	0	1
0	0	1	0	1	0

↓ parity error  
→ parity error

\* Check out the online interactive exercises for more examples: [http://gaia.cs.umass.edu/kurose\\_ross/interactive/](http://gaia.cs.umass.edu/kurose_ross/interactive/)

# Internet checksum (review, see section 3.3)

*Goal:* detect errors (*i.e.*, flipped bits) in transmitted segment

## sender:

- treat contents of UDP segment (including UDP header fields and IP addresses) as sequence of 16-bit integers
- **checksum:** addition (one's complement sum) of segment content
- checksum value put into UDP checksum field

## receiver:

- compute checksum of received segment
- check if computed checksum equals checksum field value:
  - not equal - error detected
  - equal - no error detected. *But maybe errors nonetheless?* More later ....

# Cyclic Redundancy Check (CRC)

- more powerful error-detection coding
- **D**: data bits (given, think of these as a binary number)
- **G**: bit pattern (generator), of  $r+1$  bits (given, specified in CRC standard)



- sender*: compute  $r$  CRC bits, **R**, such that  $\langle D, R \rangle$  *exactly* divisible by  $G \pmod{2}$
- receiver knows  $G$ , divides  $\langle D, R \rangle$  by  $G$ . If non-zero remainder: error detected!
  - can detect all burst errors less than  $r+1$  bits
  - widely used in practice (Ethernet, 802.11 WiFi)

# Cyclic Redundancy Check (CRC): example

Sender wants to compute R  
such that:

$$D \cdot 2^r \text{ XOR } R = nG$$

... or equivalently (XOR R both sides):

$$D \cdot 2^r = nG \text{ XOR } R$$

... which says:

if we divide  $D \cdot 2^r$  by G, we  
want remainder R to satisfy:

$$R = \text{remainder} \left[ \frac{D \cdot 2^r}{G} \right] \text{ algorithm for computing } R$$

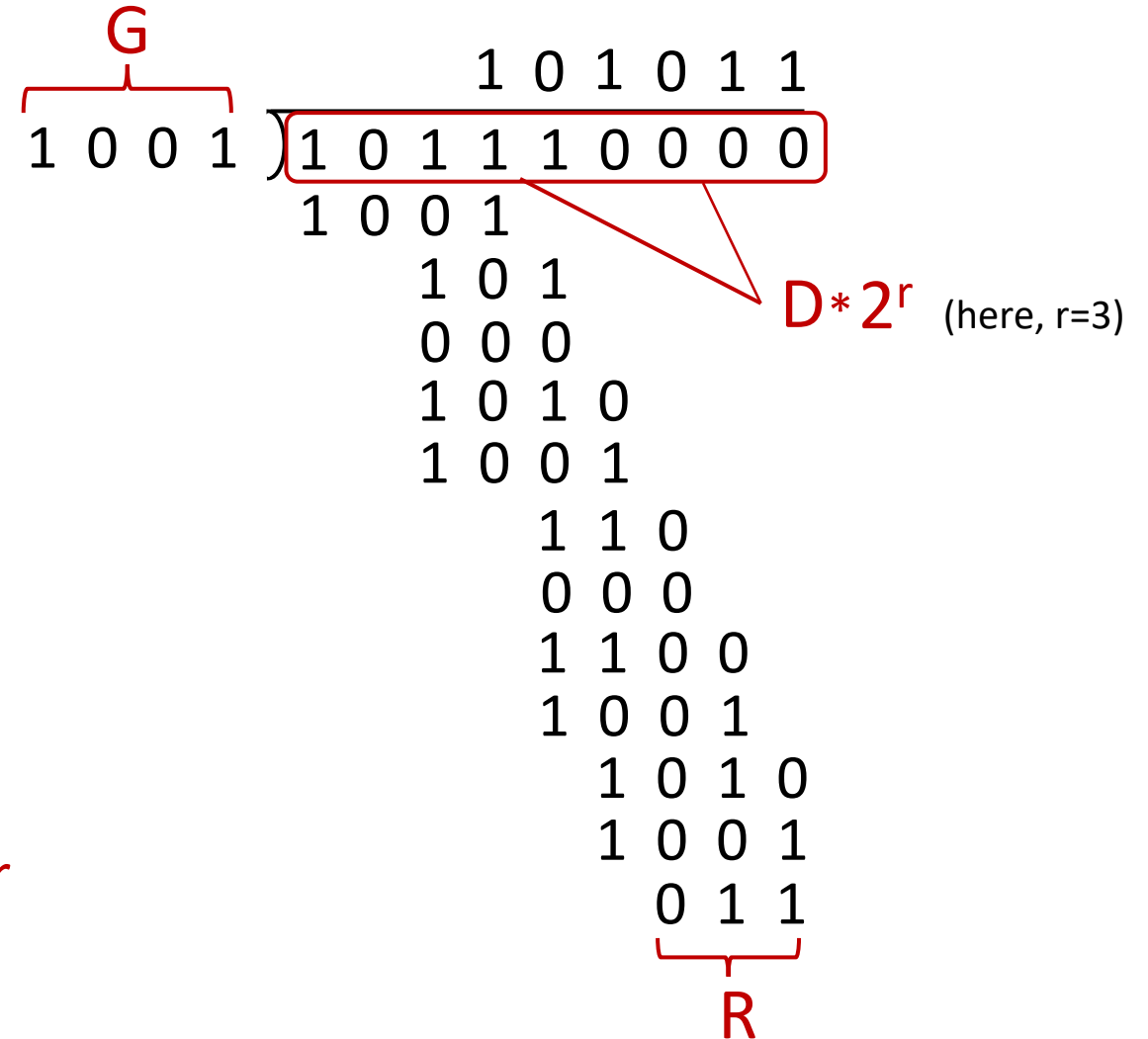

\* Check out the online interactive exercises for more examples: [http://gaia.cs.umass.edu/kurose\\_ross/interactive/](http://gaia.cs.umass.edu/kurose_ross/interactive/)

# Link layer, LANs: roadmap

- introduction
- error detection, correction
- **multiple access protocols**
- LANs
  - addressing, ARP
  - Ethernet
  - switches
  - VLANs
- link virtualization: MPLS
- data center networking



- a day in the life of a web request

# Multiple access links, protocols

two types of “links”:

- point-to-point
  - point-to-point link between Ethernet switch, host
  - PPP for dial-up access
- broadcast (shared wire or medium)
  - old-school Ethernet
  - upstream HFC in cable-based access network
  - 802.11 wireless LAN, 4G/4G. satellite



shared wire (e.g.,  
cabled Ethernet)



shared radio: 4G/5G



shared radio: WiFi

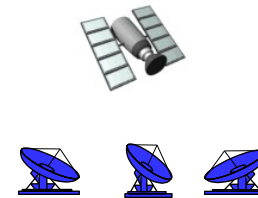

shared radio: satellite



humans at a cocktail party  
(shared air, acoustical)

# Multiple access protocols

- single shared broadcast channel
- two or more simultaneous transmissions by nodes: interference
  - *collision* if node receives two or more signals at the same time

## multiple access protocol

- distributed algorithm that determines how nodes share channel, i.e., determine when node can transmit
- communication about channel sharing must use channel itself!
  - no out-of-band channel for coordination

# An ideal multiple access protocol

*given:* multiple access channel (MAC) of rate  $R$  bps

*desiderata:*

1. when one node wants to transmit, it can send at rate  $R$ .
2. when  $M$  nodes want to transmit, each can send at average rate  $R/M$
3. fully decentralized:
  - no special node to coordinate transmissions
  - no synchronization of clocks, slots
4. simple

# MAC protocols: taxonomy

three broad classes:

- **channel partitioning**
  - divide channel into smaller “pieces” (time slots, frequency, code)
  - allocate piece to node for exclusive use
- **random access**
  - channel not divided, allow collisions
  - “recover” from collisions
- **“taking turns”**
  - nodes take turns, but nodes with more to send can take longer turns

# Channel partitioning MAC protocols: TDMA

## TDMA: time division multiple access

- access to channel in “rounds”
- each station gets fixed length slot (length = packet transmission time) in each round
- unused slots go idle
- example: 6-station LAN, 1,3,4 have packets to send, slots 2,5,6 idle

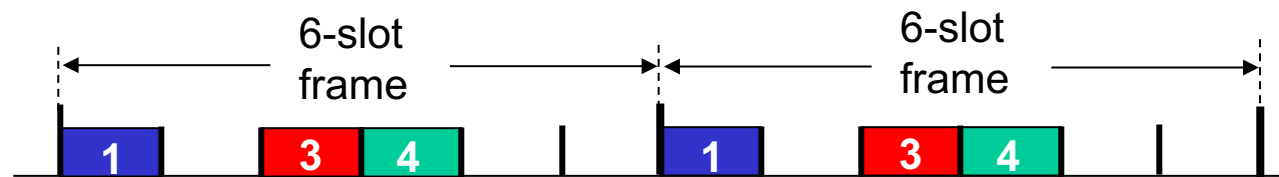

# Channel partitioning MAC protocols: FDMA

## FDMA: frequency division multiple access

- channel spectrum divided into frequency bands
- each station assigned fixed frequency band
- unused transmission time in frequency bands go idle
- example: 6-station LAN, 1,3,4 have packet to send, frequency bands 2,5,6 idle

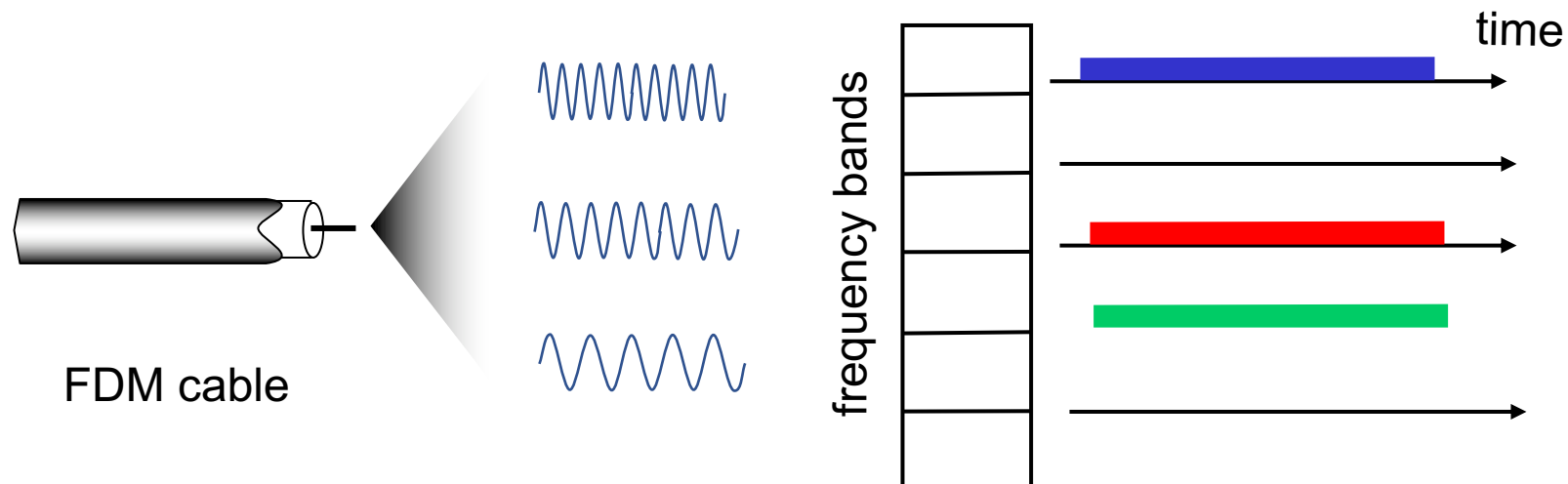

# Random access protocols

- when node has packet to send
  - transmit at full channel data rate  $R$
  - no *a priori* coordination among nodes
- two or more transmitting nodes:  
“collision”
- **random access protocol** specifies:
  - how to detect collisions
  - how to recover from collisions (e.g., via delayed retransmissions)
- examples of random access MAC protocols:
  - ALOHA, slotted ALOHA
  - CSMA, CSMA/CD, CSMA/CA

# Slotted ALOHA

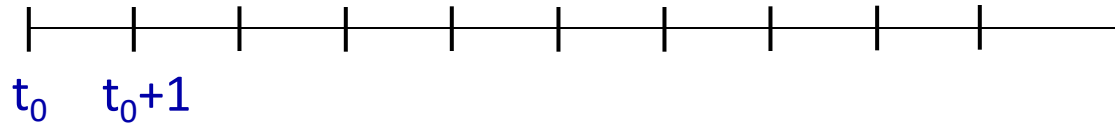

## assumptions:

- all frames same size
- time divided into equal size slots (time to transmit 1 frame)
- nodes start to transmit only slot beginning
- nodes are synchronized
- if 2 or more nodes transmit in slot, all nodes detect collision

## operation:

- when node obtains fresh frame, transmits in next slot
  - *if no collision*: node can send new frame in next slot
  - *if collision*: node retransmits frame in each subsequent slot with probability  $p$  until success

randomization – why?

# Slotted ALOHA

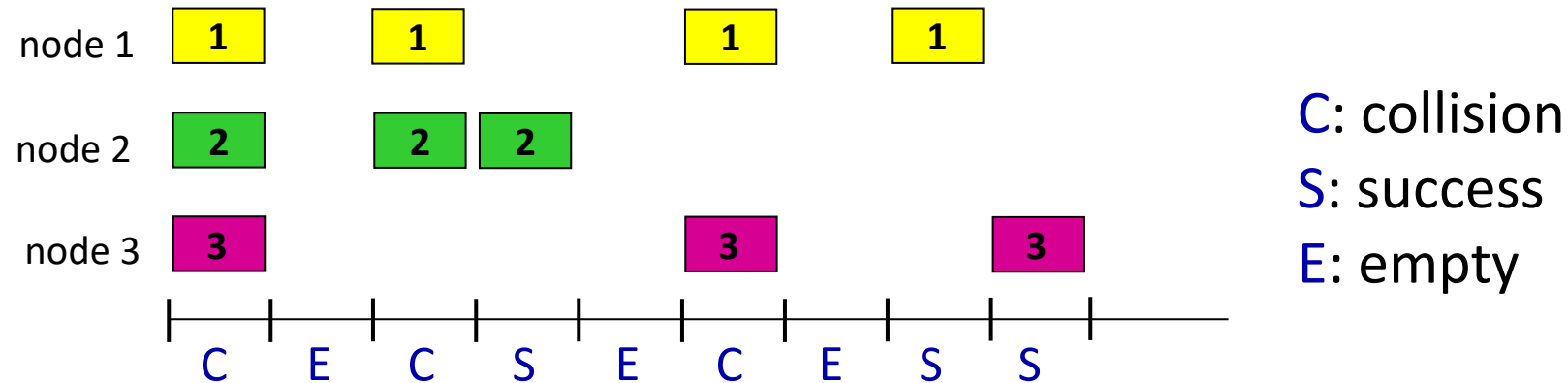

## Pros:

- single active node can continuously transmit at full rate of channel
- highly decentralized: only slots in nodes need to be in sync
- simple

## Cons:

- collisions, wasting slots
- idle slots
- nodes may be able to detect collision in less than time to transmit packet
- clock synchronization

# Slotted ALOHA: efficiency

**efficiency:** long-run fraction of successful slots (many nodes, all with many frames to send)

- *suppose:*  $N$  nodes with many frames to send, each transmits in slot with probability  $p$ 
  - prob that given node has success in a slot =  $p(1-p)^{N-1}$
  - prob that *any* node has a success =  $Np(1-p)^{N-1}$
  - max efficiency: find  $p^*$  that maximizes  $Np(1-p)^{N-1}$
  - for many nodes, take limit of  $Np^*(1-p^*)^{N-1}$  as  $N$  goes to infinity, gives:

*max efficiency =  $1/e = .37$*

- *at best:* channel used for useful transmissions 37% of time!



# CSMA (carrier sense multiple access)

simple **CSMA**: listen before transmit:

- if channel sensed idle: transmit entire frame
- if channel sensed busy: defer transmission
- human analogy: don't interrupt others!

**CSMA/CD**: CSMA with *collision detection*

- collisions *detected* within short time
- colliding transmissions aborted, reducing channel wastage
- collision detection easy in wired, difficult with wireless
- human analogy: the polite conversationalist

# CSMA: collisions

- collisions can *still* occur with carrier sensing:
  - **propagation delay** means two nodes may not hear each other's just-started transmission
- **collision**: entire packet transmission time wasted
  - distance & propagation delay play role in determining collision probability

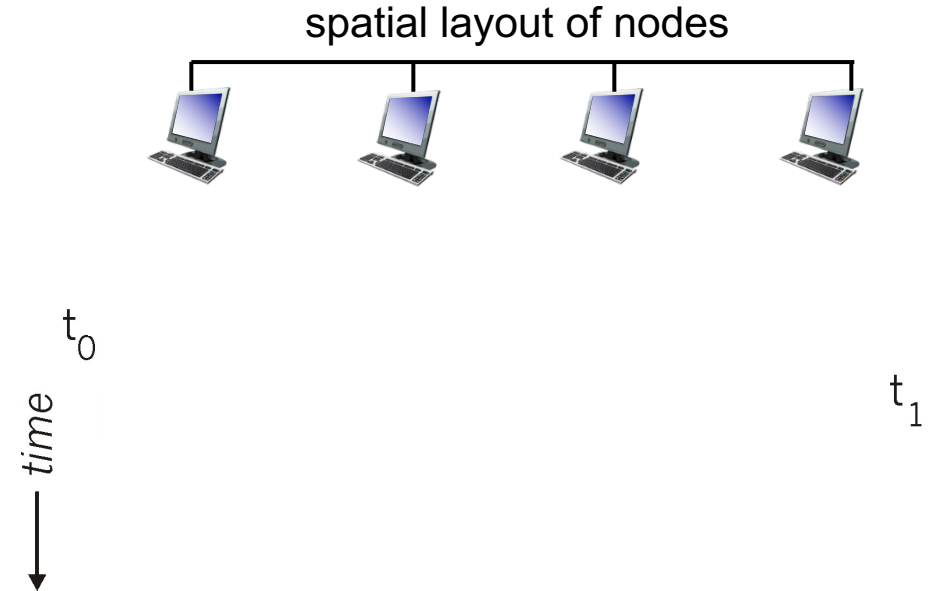

# CSMA/CD:

- CSMA/CD reduces the amount of time wasted in collisions
  - transmission aborted on collision detection

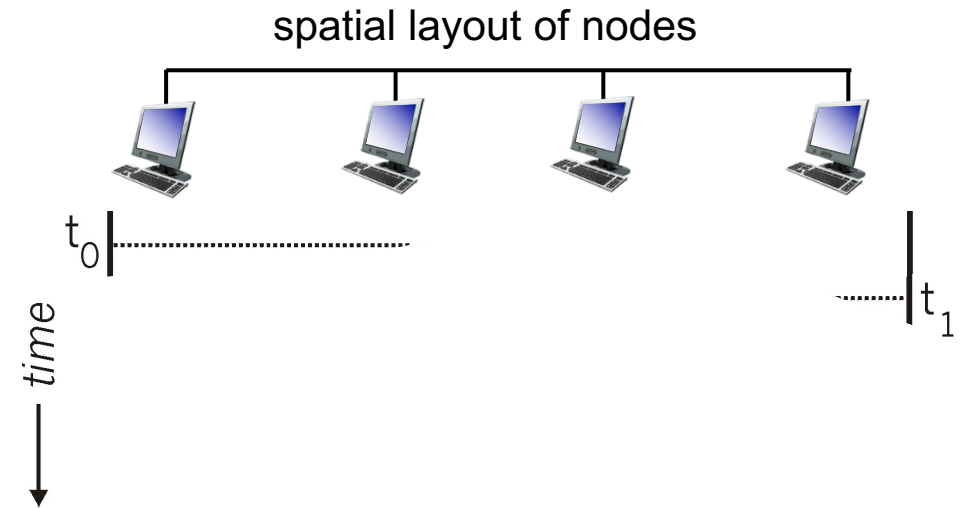

# Ethernet CSMA/CD algorithm

1. Ethernet receives datagram from network layer, creates frame
2. If Ethernet senses channel:
  - if **idle**: start frame transmission.
  - if **busy**: wait until channel idle, then transmit
3. If entire frame transmitted without collision - done!
4. If another transmission detected while sending: abort, send jam signal
5. After aborting, enter *binary (exponential) backoff*:
  - after  $m$ th collision, chooses  $K$  at random from  $\{0, 1, 2, \dots, 2^m - 1\}$ . Ethernet waits  $K \cdot 512$  bit times, returns to Step 2
  - more collisions: longer backoff interval

# “Taking turns” MAC protocols

## channel partitioning MAC protocols:

- share channel *efficiently* and *fairly* at high load
- inefficient at low load: delay in channel access,  $1/N$  bandwidth allocated even if only 1 active node!

## random access MAC protocols

- efficient at low load: single node can fully utilize channel
- high load: collision overhead

## “taking turns” protocols

- look for best of both worlds!

# “Taking turns” MAC protocols

## polling:

- centralized controller “invites” other nodes to transmit in turn
- typically used with “dumb” devices
- concerns:
  - polling overhead
  - latency
  - single point of failure (master)
- Bluetooth uses polling

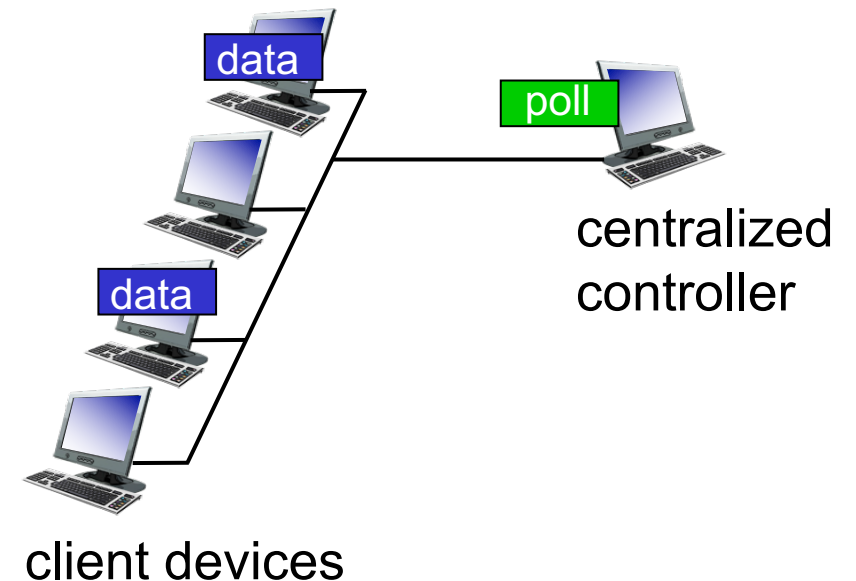

# “Taking turns” MAC protocols

## token passing:

- control *token* message explicitly passed from one node to next, sequentially
  - transmit while holding token
- concerns:
  - token overhead
  - latency
  - single point of failure (token)

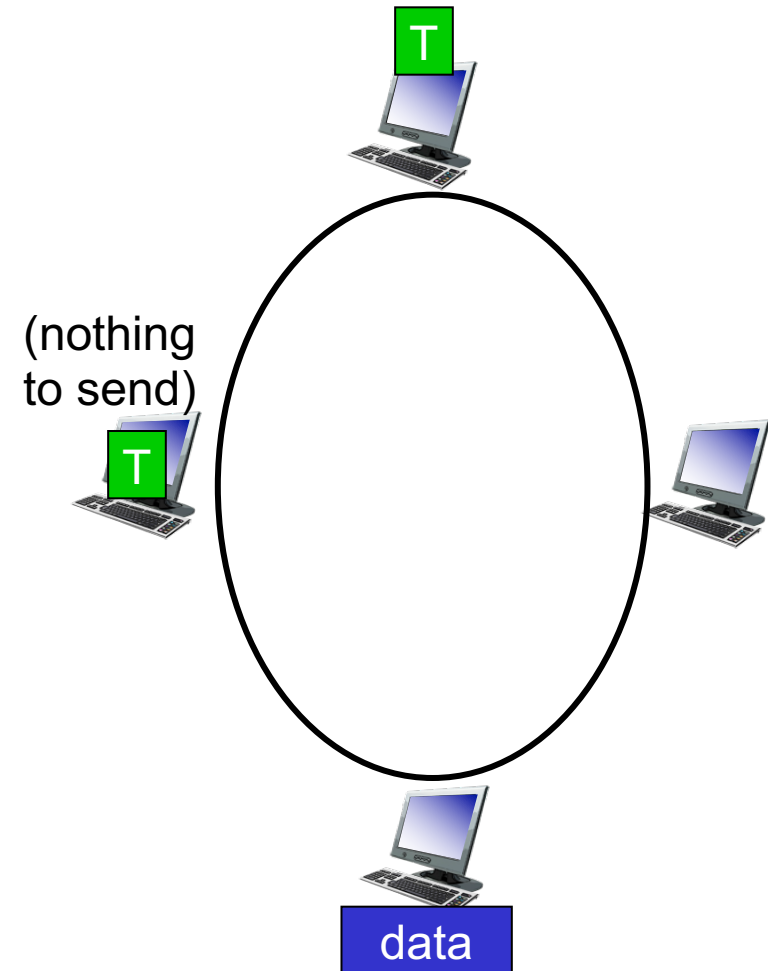

# Cable access network: FDM, TDM *and* random access!

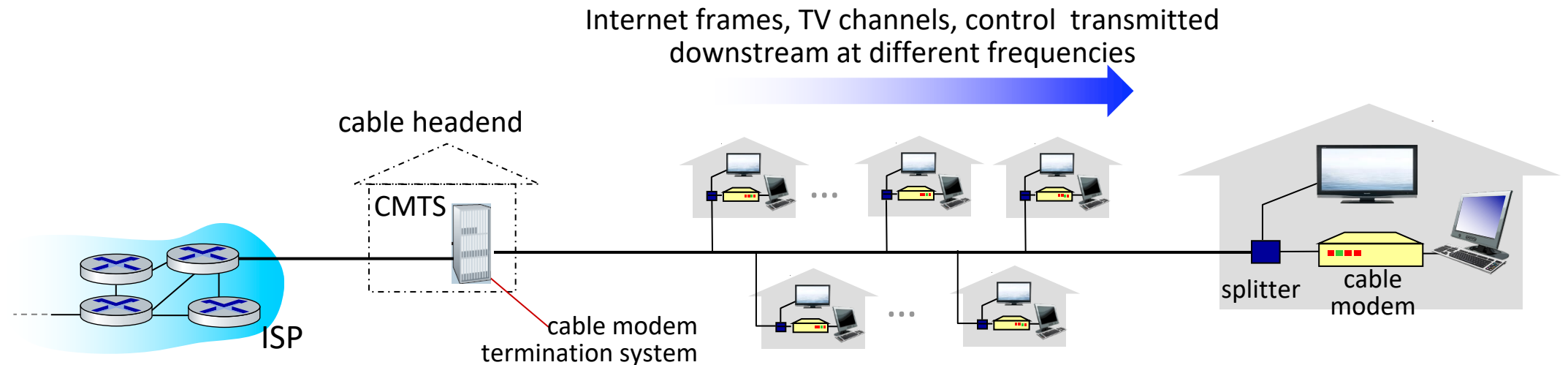

- **multiple** downstream (broadcast) FDM channels: up to 1.6 Gbps/channel
  - single CMTS transmits into channels
- **multiple** upstream channels (up to 1 Gbps/channel)
  - **multiple access**: all users contend (random access) for certain upstream channel time slots; others assigned TDM

# Cable access network:

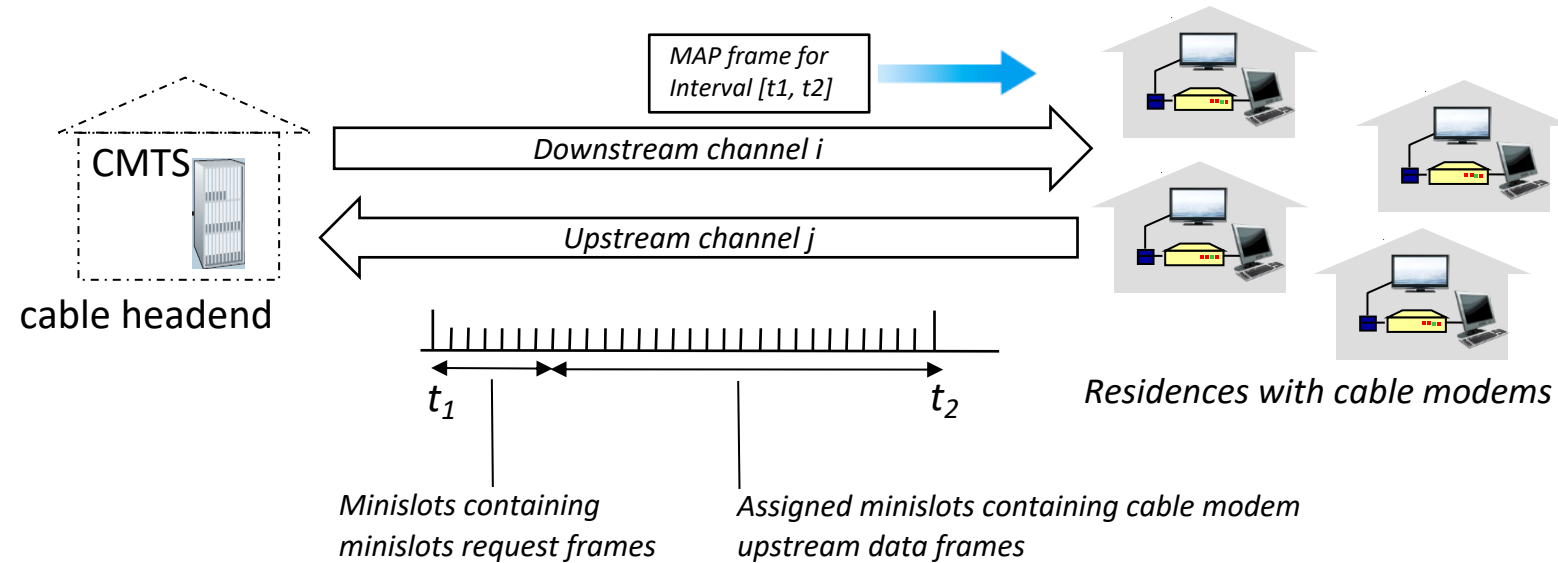

## DOCSIS: data over cable service interface specification

- FDM over upstream, downstream frequency channels
- TDM upstream: some slots assigned, some have contention
  - downstream MAP frame: assigns upstream slots
  - request for upstream slots (and data) transmitted random access (binary backoff) in selected slots

# Summary of MAC protocols

- **channel partitioning**, by time, frequency or code
  - Time Division, Frequency Division
- **random access** (dynamic),
  - ALOHA, S-ALOHA, CSMA, CSMA/CD
  - carrier sensing: easy in some technologies (wire), hard in others (wireless)
  - CSMA/CD used in Ethernet
  - CSMA/CA used in 802.11
- **taking turns**
  - polling from central site, token passing
  - Bluetooth, FDDI, token ring

# Link layer, LANs: roadmap

- introduction
- error detection, correction
- multiple access protocols
- **LANs**
  - **addressing, ARP**
  - Ethernet
  - switches
  - VLANs
- link virtualization: MPLS
- data center networking



- a day in the life of a web request

# MAC addresses

- 32-bit IP address:
  - *network-layer* address for interface
  - used for layer 3 (network layer) forwarding
  - e.g.: 128.119.40.136
- MAC (or LAN or physical or Ethernet) address:
  - function: used “locally” to get frame from one interface to another physically-connected interface (same subnet, in IP-addressing sense)
  - 48-bit MAC address (for most LANs) burned in NIC ROM, also sometimes software settable
  - e.g.: 1A-2F-BB-76-09-AD
    - *hexadecimal (base 16) notation*  
*(each “numeral” represents 4 bits)*

# MAC addresses

each interface on LAN

- has unique 48-bit **MAC** address
- has a locally unique 32-bit IP address (as we've seen)

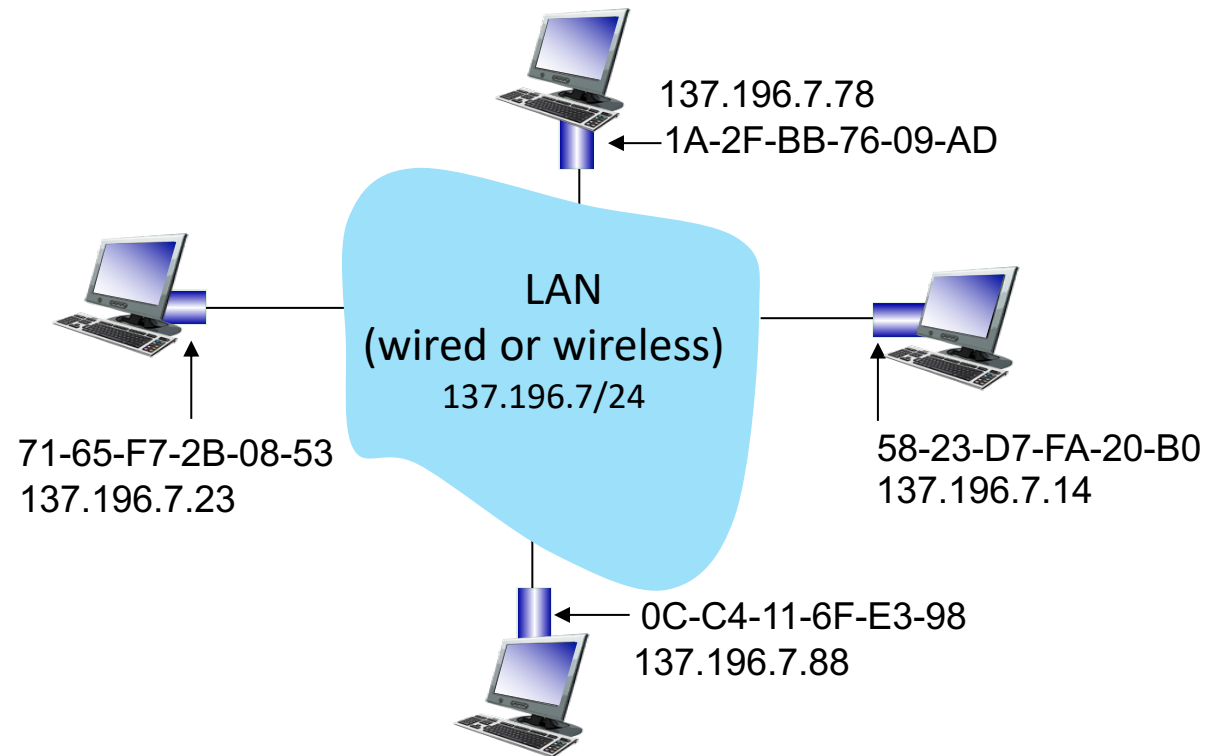

# MAC addresses

- MAC address allocation administered by IEEE
- manufacturer buys portion of MAC address space (to assure uniqueness)
- analogy:
  - MAC address: like Social Security Number
  - IP address: like postal address
- MAC flat address: portability
  - can move interface from one LAN to another
  - recall IP address *not* portable: depends on IP subnet to which node is attached

# ARP: address resolution protocol

*Question:* how to determine interface's MAC address, knowing its IP address?

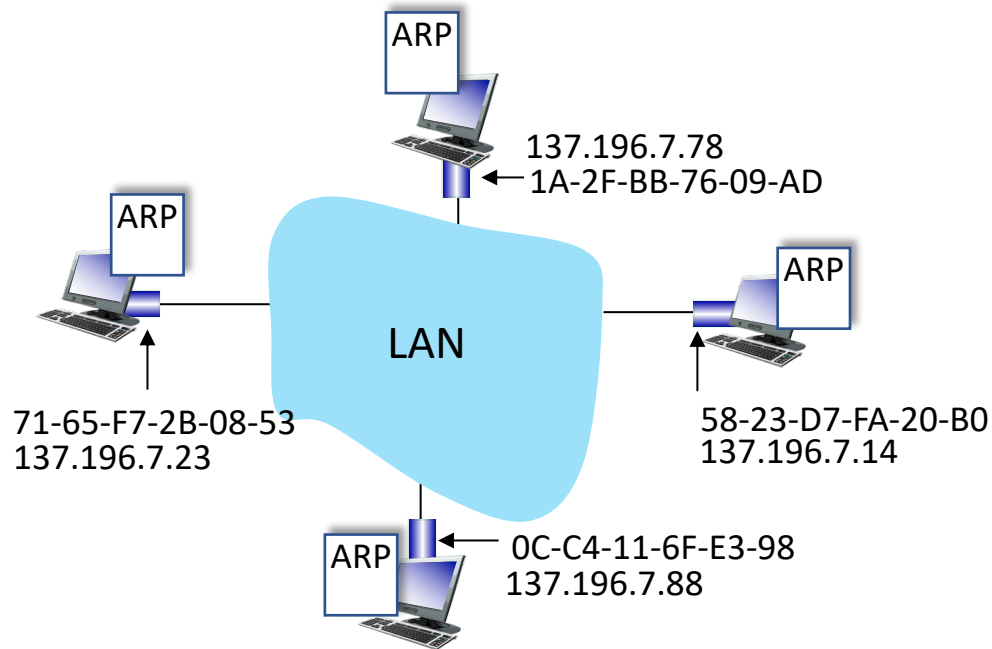

**ARP table:** each IP node (host, router) on LAN has table

- IP/MAC address mappings for some LAN nodes:  
< IP address; MAC address; TTL >
- TTL (Time To Live): time after which address mapping will be forgotten (typically 20 min)

# ARP protocol in action

example: A wants to send datagram to B

- B's MAC address not in A's ARP table, so A uses ARP to find B's MAC address

A broadcasts ARP query, containing B's IP addr

- ①
- destination MAC address = FF-FF-FF-FF-FF-FF
  - all nodes on LAN receive ARP query

ARP table in A

IP addr	MAC addr	TTL

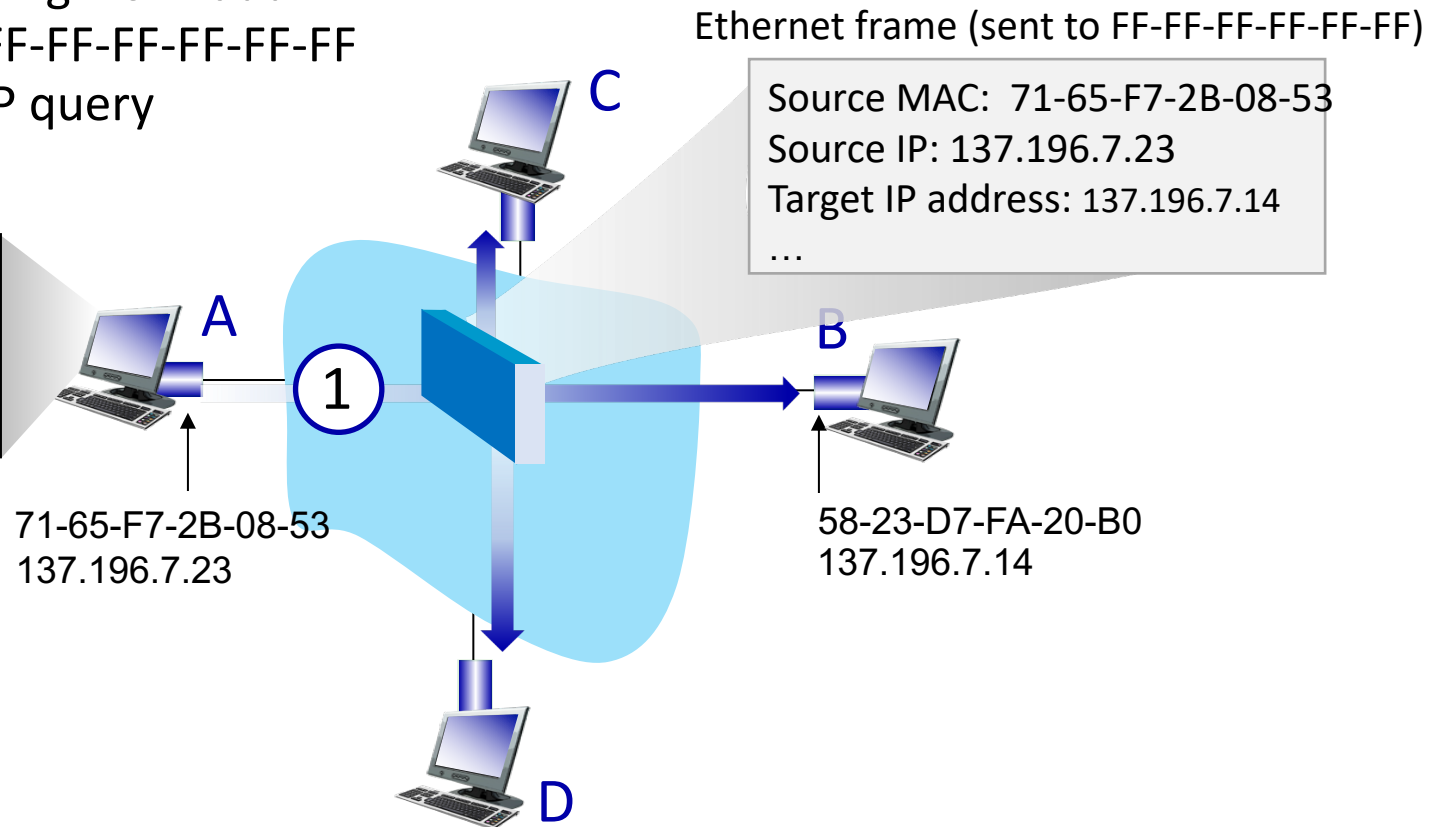

# ARP protocol in action

example: A wants to send datagram to B

- B's MAC address not in A's ARP table, so A uses ARP to find B's MAC address

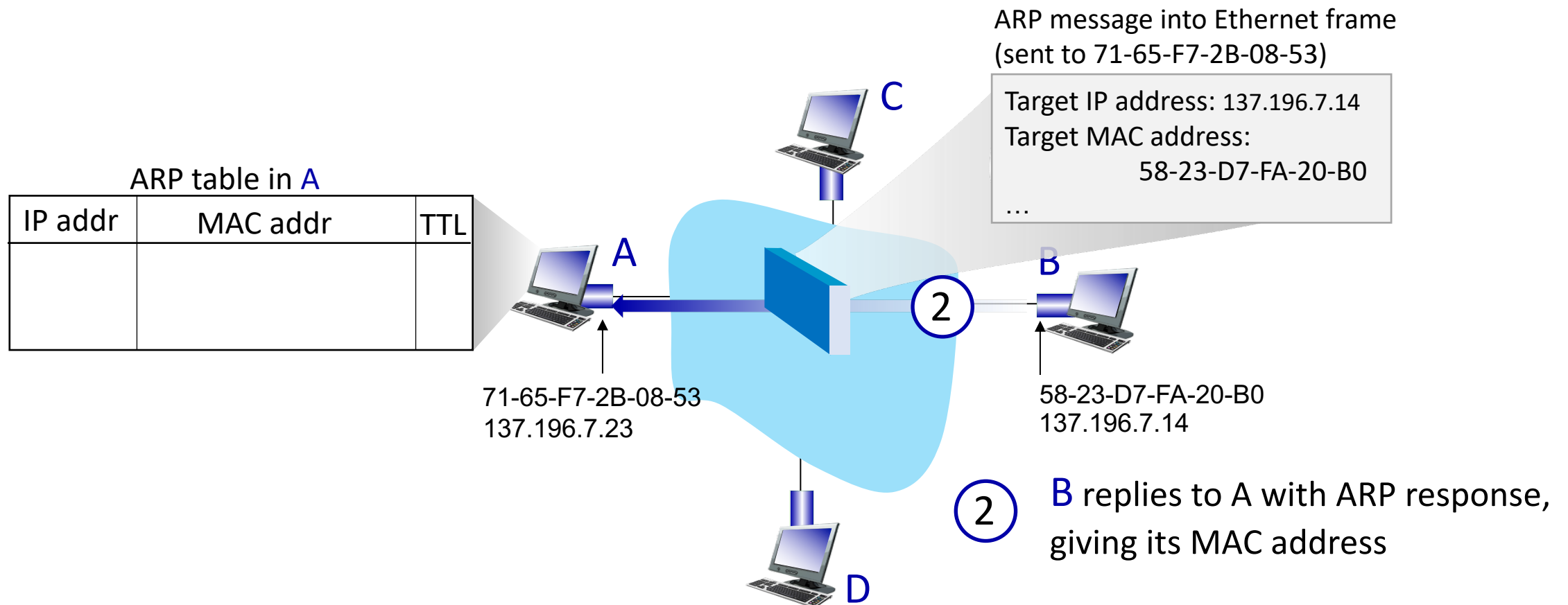

# ARP protocol in action

example: A wants to send datagram to B

- B's MAC address not in A's ARP table, so A uses ARP to find B's MAC address

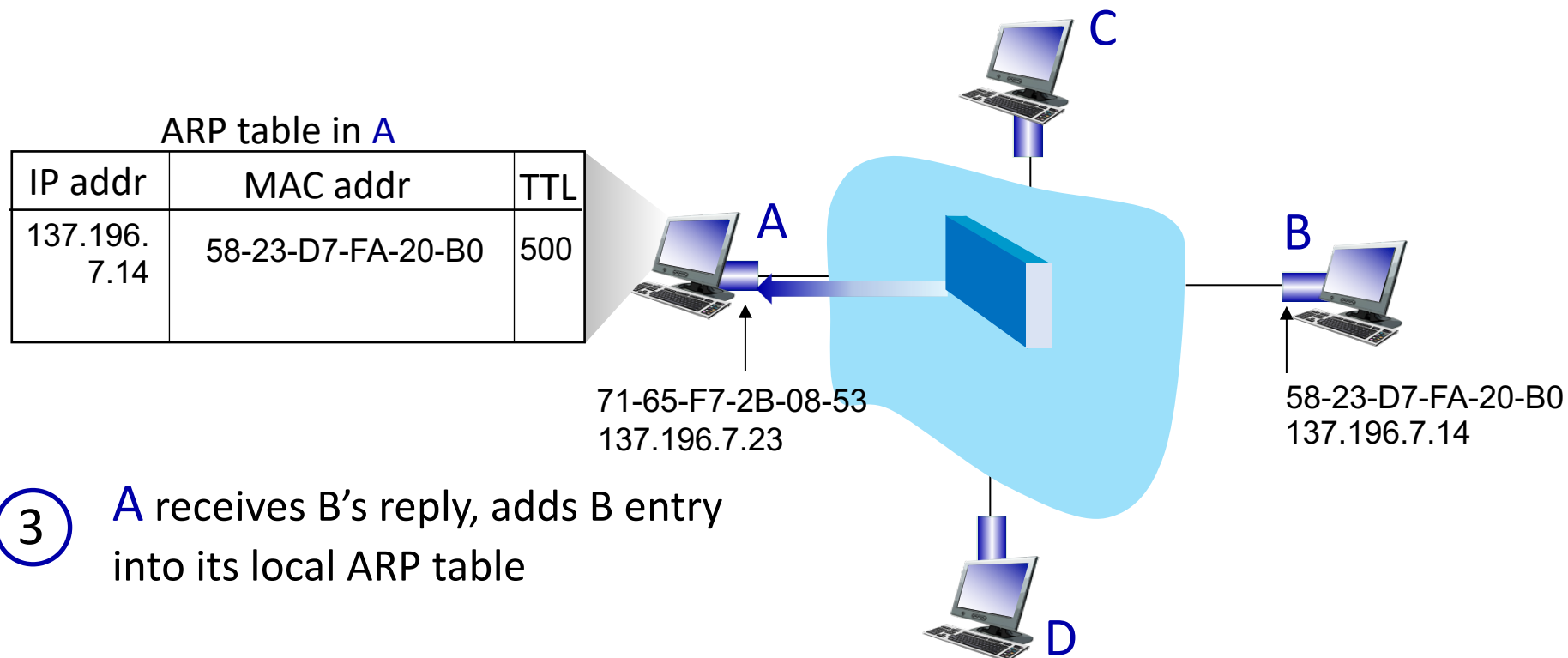

# Routing to another subnet: addressing

walkthrough: sending a datagram from *A* to *B* via *R*

- focus on addressing – at IP (datagram) and MAC layer (frame) levels
- assume that:
  - A knows B's IP address
  - A knows IP address of first hop router, R (how?)
  - A knows R's MAC address (how?)

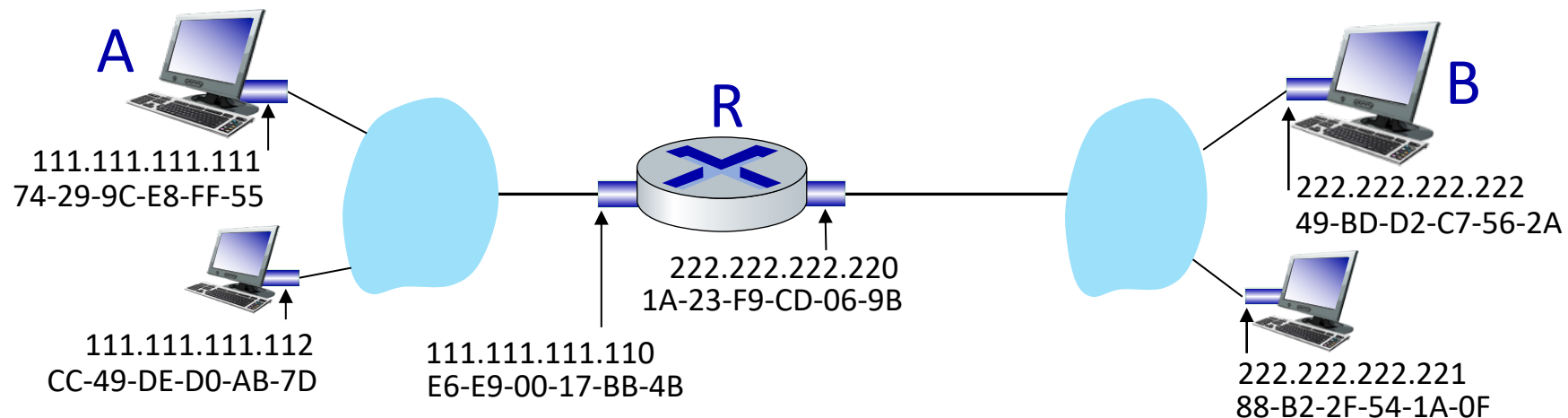

# Routing to another subnet: addressing

- A creates IP datagram with IP source A, destination B
- A creates link-layer frame containing A-to-B IP datagram
  - R's MAC address is frame's destination

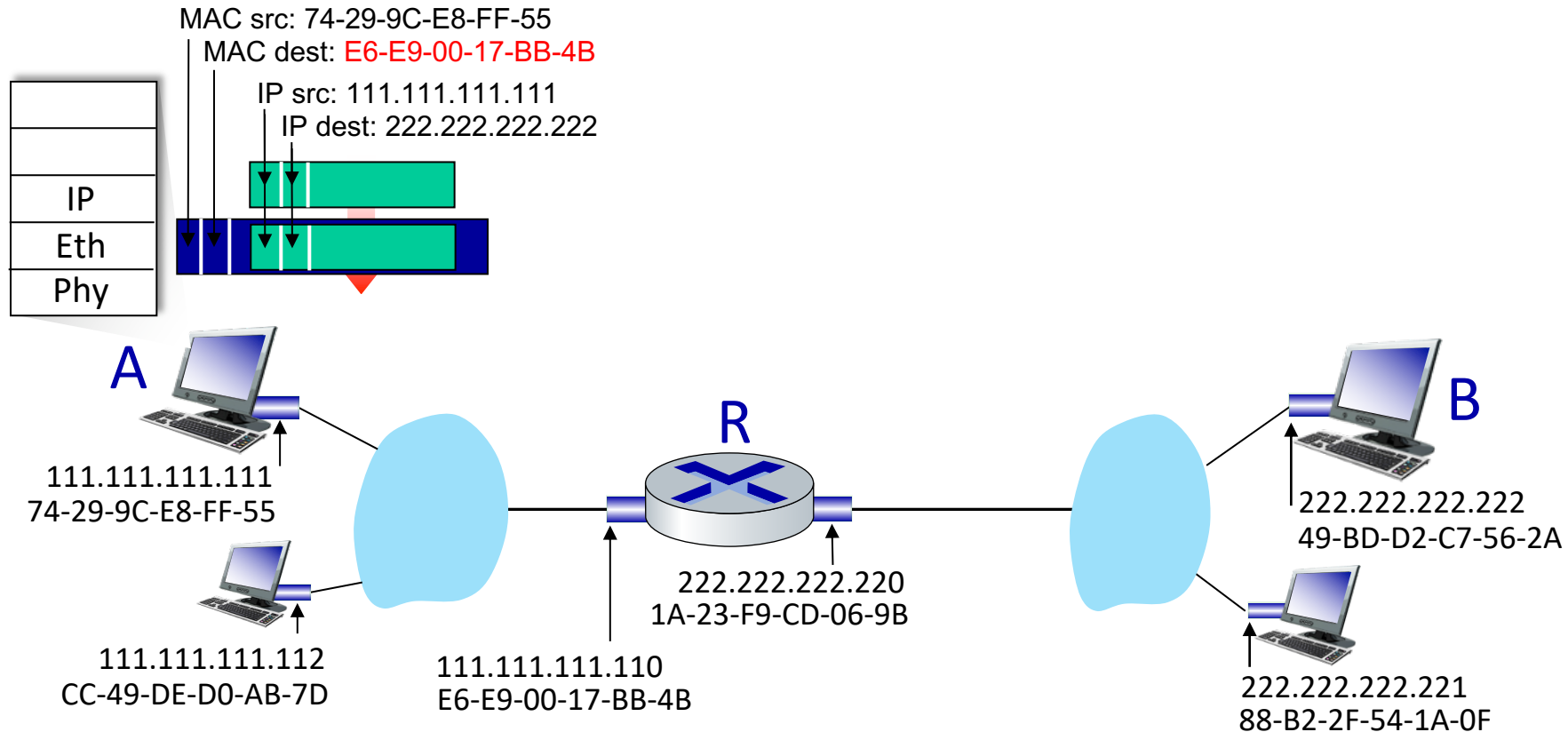

# Routing to another subnet: addressing

- frame sent from A to R
- frame received at R, datagram removed, passed up to IP

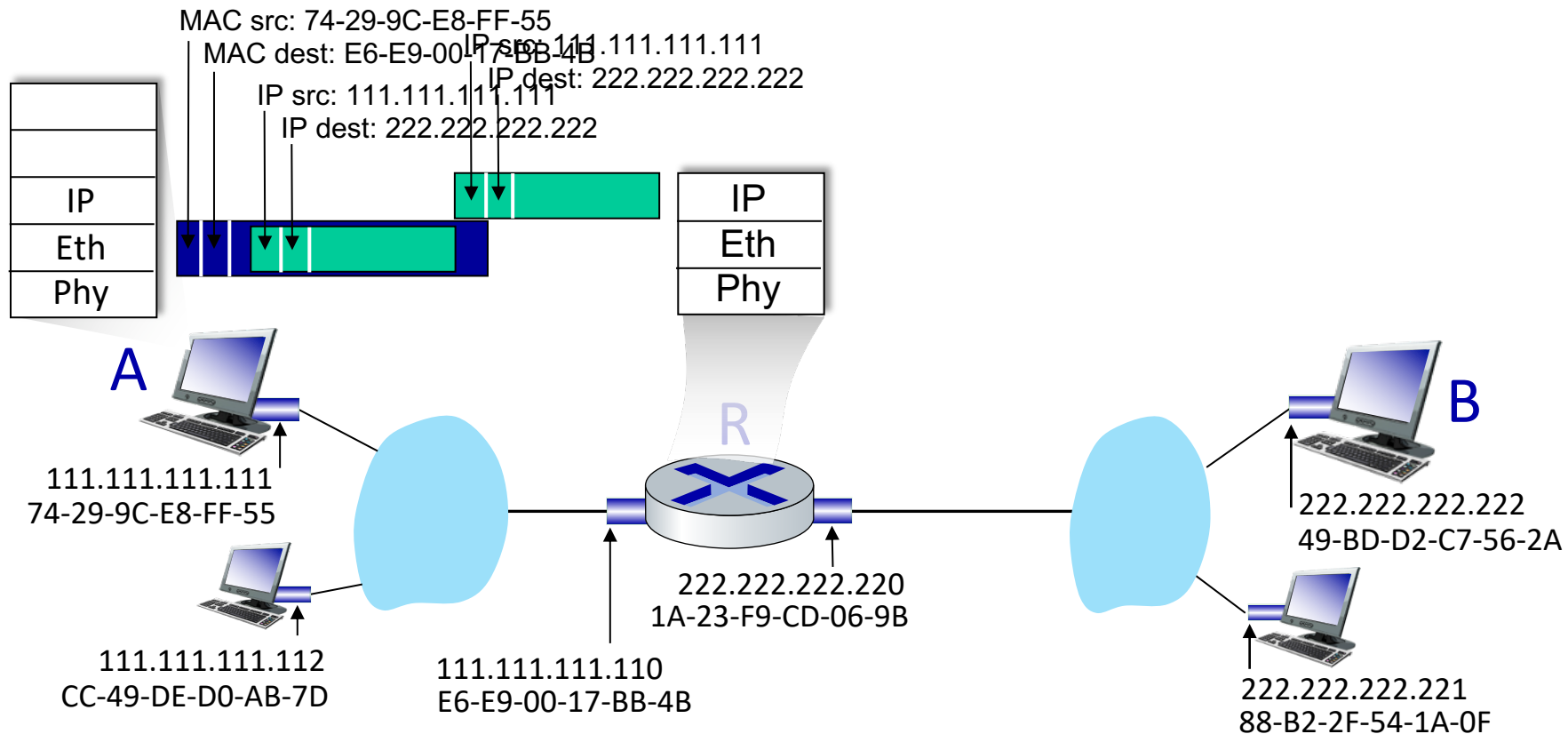

# Routing to another subnet: addressing

- R determines outgoing interface, passes datagram with IP source A, destination B to link layer
- R creates link-layer frame containing A-to-B IP datagram. Frame destination address: B's MAC address

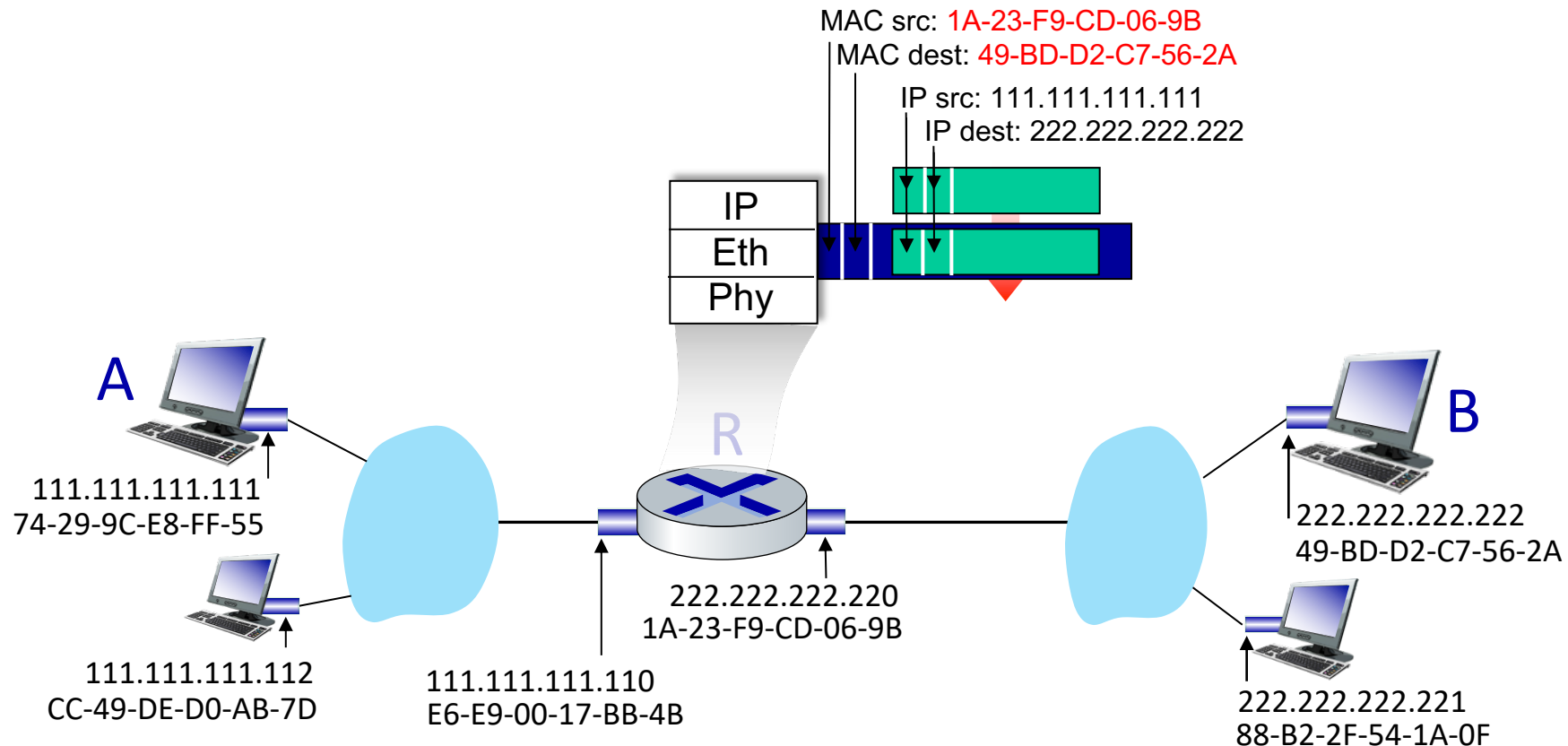

# Routing to another subnet: addressing

- R determines outgoing interface, passes datagram with IP source A, destination B to link layer
- R creates link-layer frame containing A-to-B IP datagram. Frame destination address: B's MAC address
- transmits link-layer frame

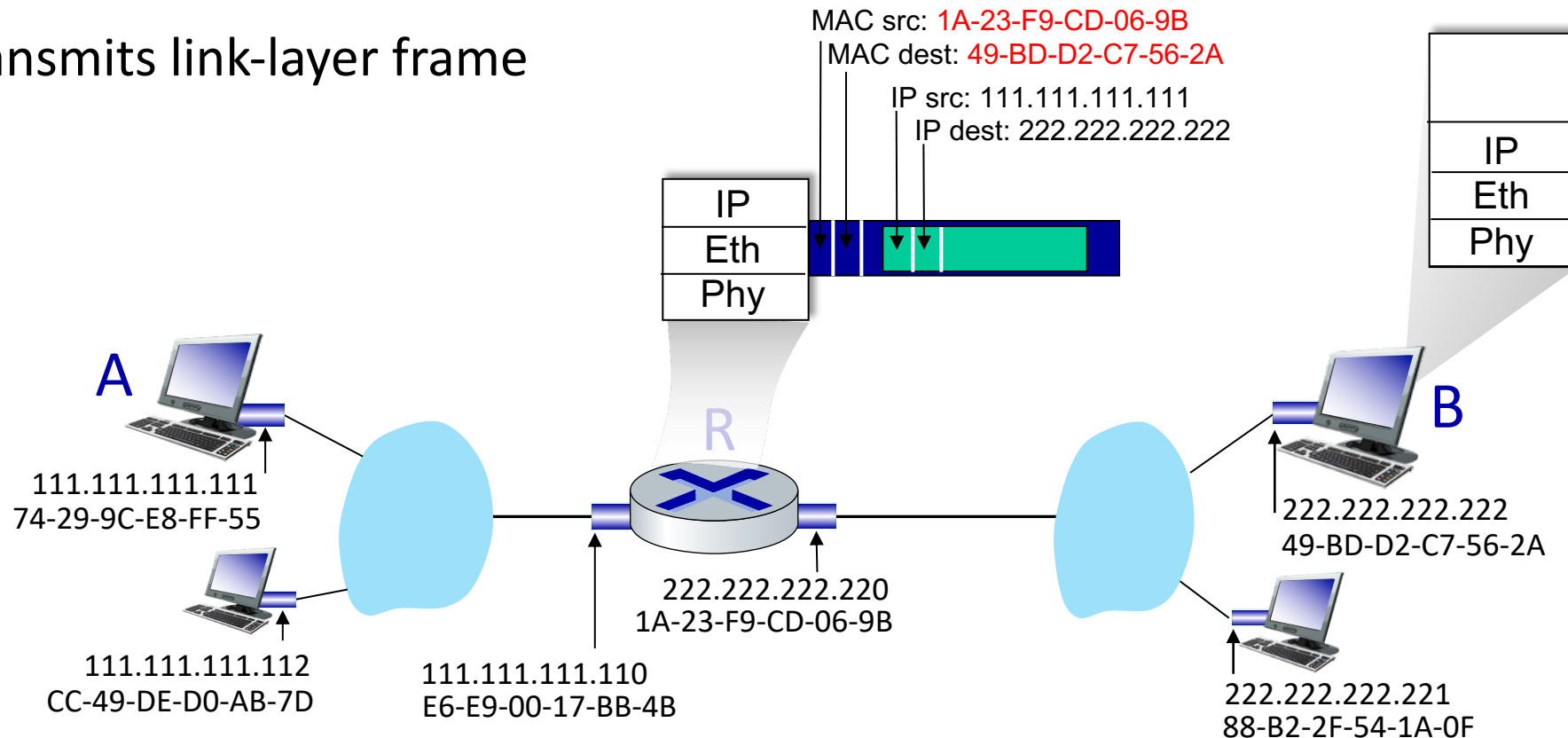

# Routing to another subnet: addressing

- B receives frame, extracts IP datagram destination B
- B passes datagram up protocol stack to IP

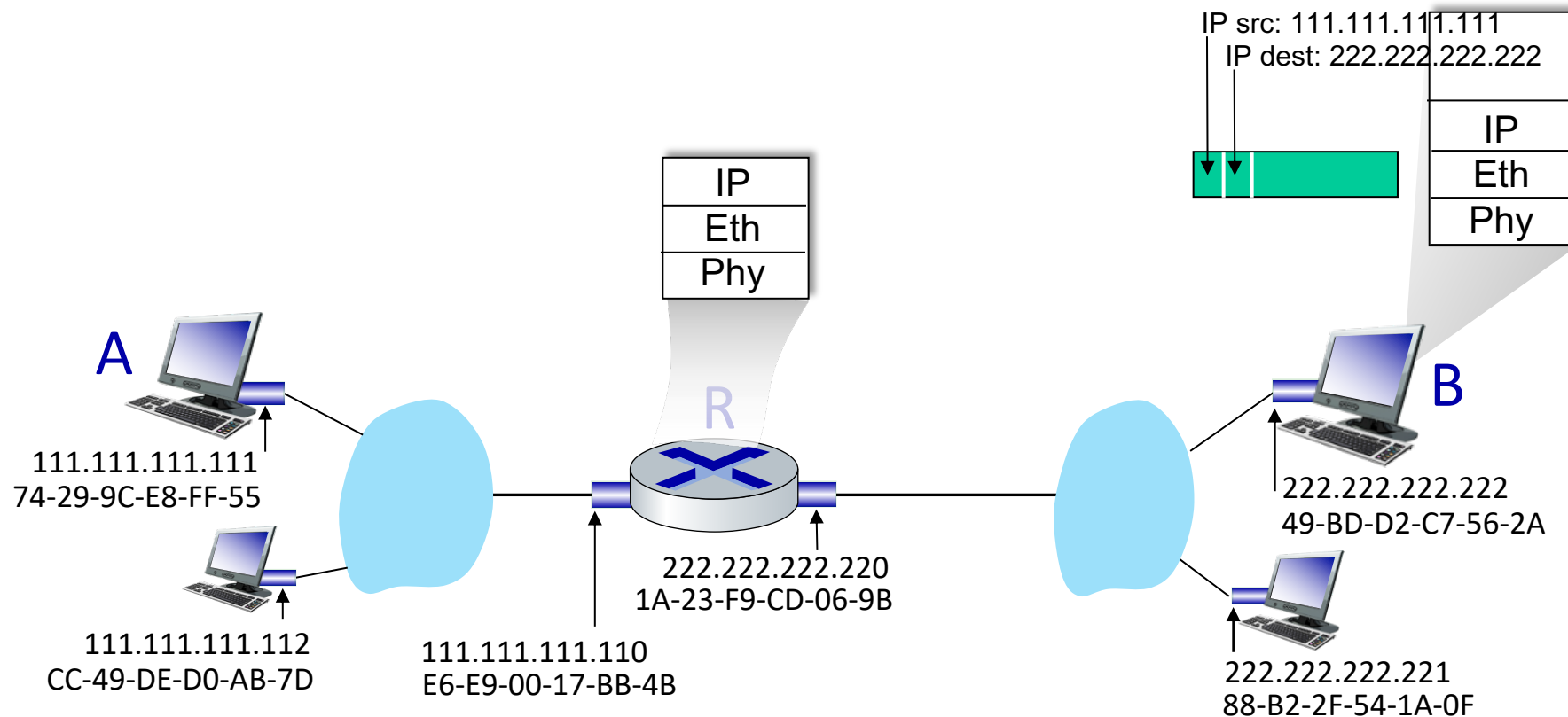

# Link layer, LANs: roadmap

- introduction
- error detection, correction
- multiple access protocols
- **LANs**
  - addressing, ARP
  - **Ethernet**
  - switches
  - VLANs
- link virtualization: MPLS
- data center networking



- a day in the life of a web request

# Ethernet

“dominant” wired LAN technology:

- first widely used LAN technology
- simpler, cheap
- kept up with speed race: 10 Mbps – 400 Gbps
- single chip, multiple speeds (e.g., Broadcom BCM5761)

*Metcalfe's Ethernet sketch*

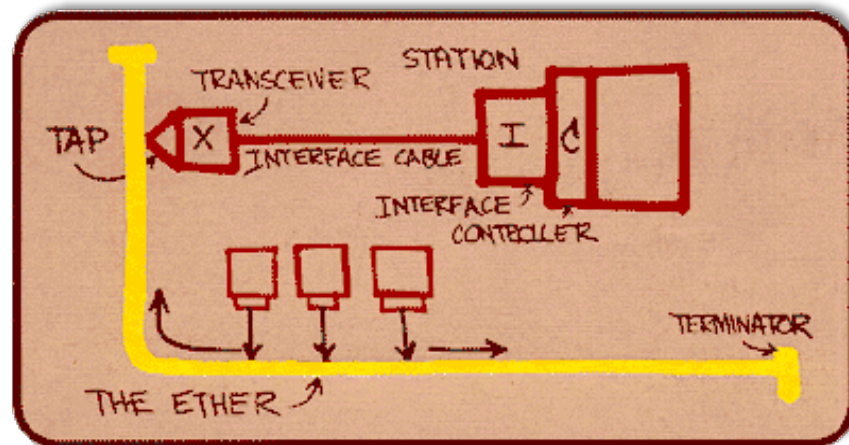

Bob Metcalfe: Ethernet co-inventor,  
2022 ACM Turing Award recipient



# Ethernet: physical topology

- **bus:** popular through mid 90s
  - all nodes in same collision domain (can collide with each other)
- **switched:** prevails today
  - active link-layer 2 *switch* in center
  - each “spoke” runs a (separate) Ethernet protocol (nodes do not collide with each other)

bus: coaxial cable

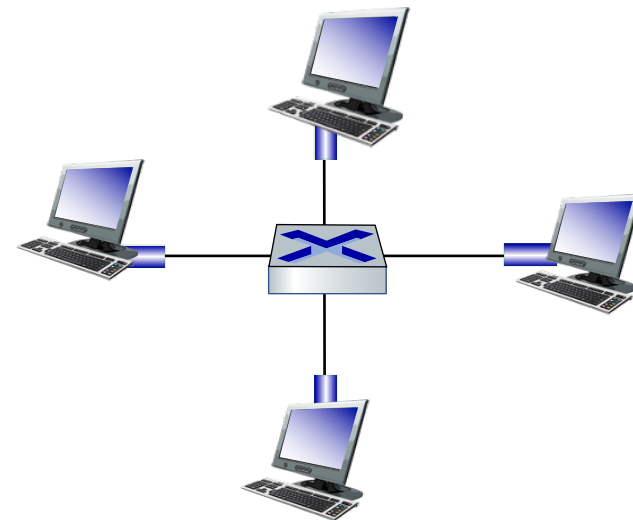
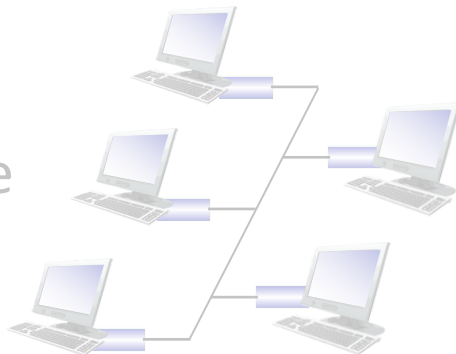

switched

# Ethernet frame structure

sending interface encapsulates IP datagram (or other network layer protocol packet) in **Ethernet frame**



## *preamble:*

- used to synchronize receiver, sender clock rates
- 7 bytes of 10101010 followed by one byte of 10101011

# Ethernet frame structure (more)

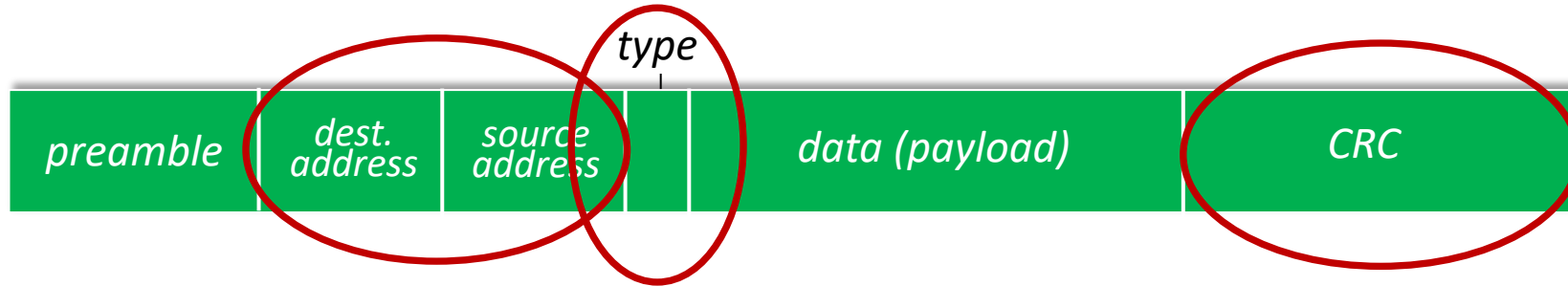

- **addresses:** 6 byte source, destination MAC addresses
  - if adapter receives frame with matching destination address, or with broadcast address (e.g., ARP packet), it passes data in frame to network layer protocol
  - otherwise, adapter discards frame
- **type:** indicates higher layer protocol
  - mostly IP but others possible, e.g., Novell IPX, AppleTalk
  - used to demultiplex up at receiver
- **CRC:** cyclic redundancy check at receiver
  - error detected: frame is dropped

# Ethernet: unreliable, connectionless

- **connectionless**: no handshaking between sending and receiving NICs
- **unreliable**: receiving NIC doesn't send ACKs or NAKs to sending NIC
  - data in dropped frames recovered only if initial sender uses higher layer rdt (e.g., TCP), otherwise dropped data lost
- Ethernet's MAC protocol: unslotted **CSMA/CD with binary backoff**

# 802.3 Ethernet standards: link & physical layers

- *many* different Ethernet standards
  - common MAC protocol and frame format
  - different speeds: 2 Mbps, ... 100 Mbps, 1Gbps, 10 Gbps, 40 Gbps, 80 Gbps
    - different physical layer media: fiber, cable

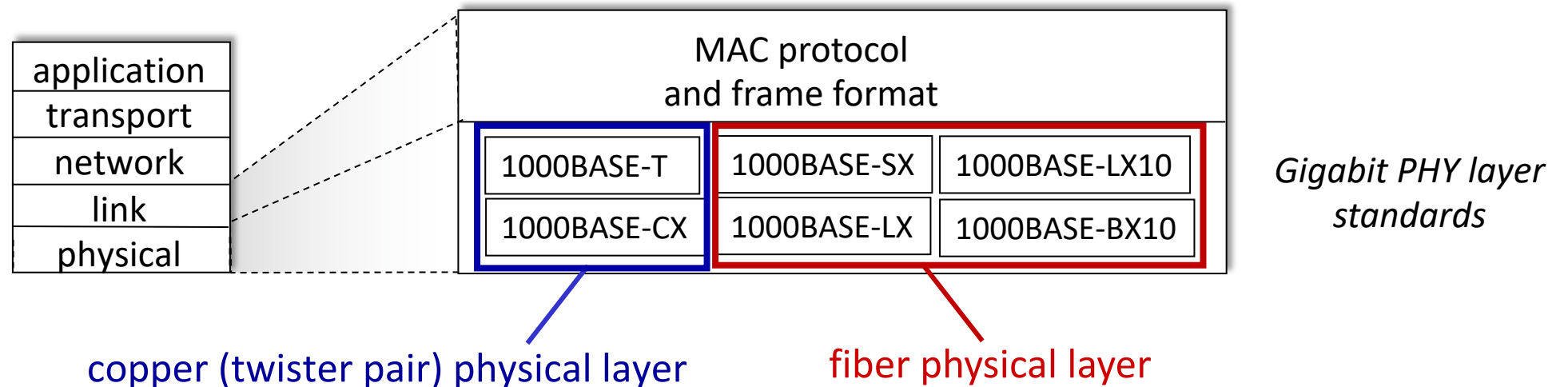

# Link layer, LANs: roadmap

- introduction
- error detection, correction
- multiple access protocols
- **LANs**
  - addressing, ARP
  - Ethernet
  - **switches**
  - VLANs
- link virtualization: MPLS
- data center networking



- a day in the life of a web request

# Ethernet switch

- Switch is a **link-layer** device: takes an *active* role
  - store, forward Ethernet (or other type of) frames
  - examine incoming frame's MAC address, *selectively* forward frame to one-or-more outgoing links when frame is to be forwarded on segment, uses CSMA/CD to access segment
- **transparent:** hosts *unaware* of presence of switches
- **plug-and-play, self-learning**
  - switches do not need to be configured

# Switch: multiple simultaneous transmissions

- hosts have dedicated, direct connection to switch
- switches buffer packets
- Ethernet protocol used on *each* incoming link, so:
  - no collisions; full duplex
  - each link is its own collision domain
- **switching**: A-to-A' and B-to-B' can transmit simultaneously, without collisions

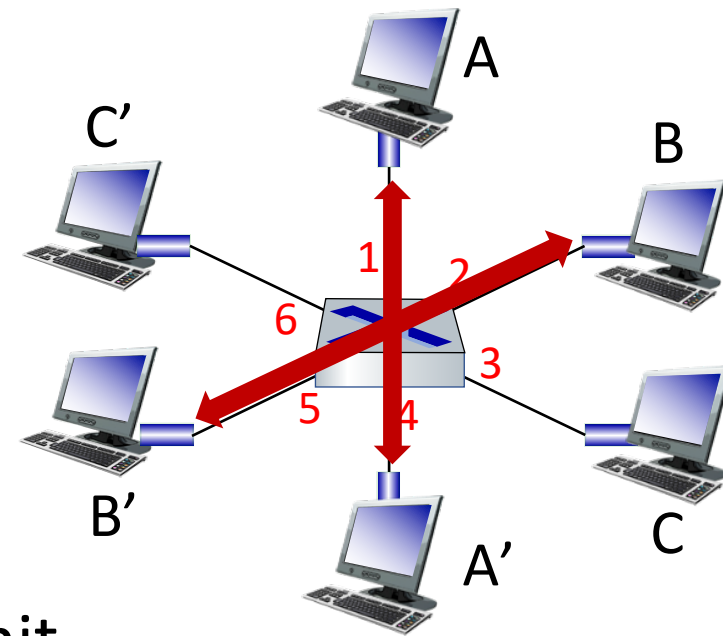

switch with six interfaces (1,2,3,4,5,6)

# Switch: multiple simultaneous transmissions

- hosts have dedicated, direct connection to switch
- switches buffer packets
- Ethernet protocol used on *each* incoming link, so:
  - no collisions; full duplex
  - each link is its own collision domain
- **switching:** A-to-A' and B-to-B' can transmit simultaneously, without collisions
  - but A-to-A' and C to A' can *not* happen simultaneously

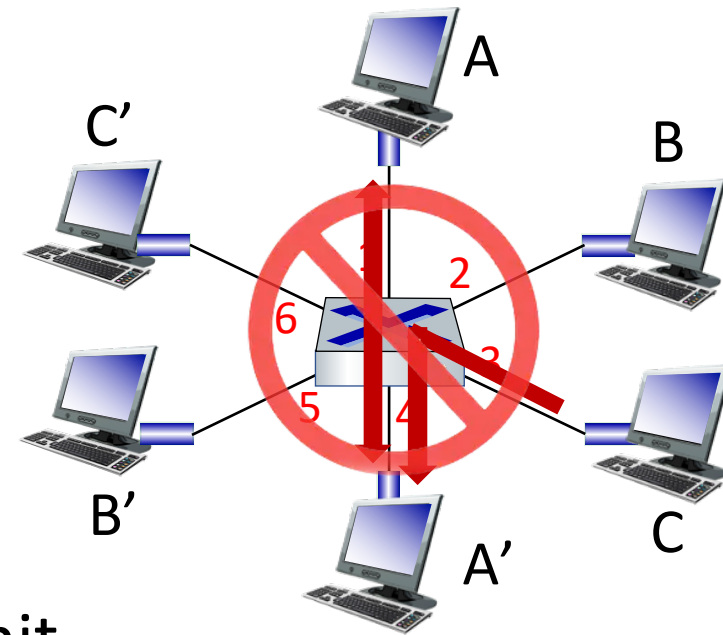

switch with six interfaces (1,2,3,4,5,6)

# Switch forwarding table

Q: how does switch know A' reachable via interface 4, B' reachable via interface 5?

A: each switch has a **switch table**, each entry:

- (MAC address of host, interface to reach host, time stamp)
- looks like a routing table!

Q: how are entries created, maintained in switch table?

- something like a routing protocol?

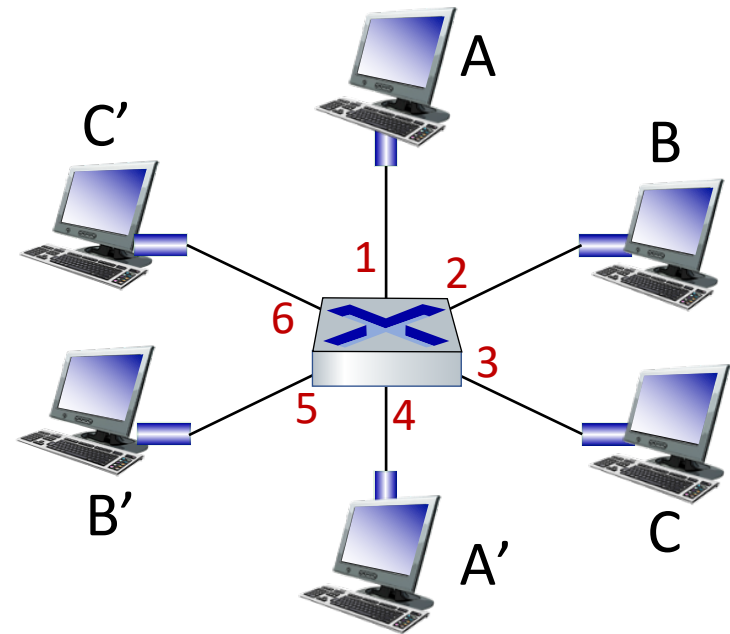

# Switch: self-learning

- switch *learns* which hosts can be reached through which interfaces
- when frame received, switch “learns” location of sender: incoming LAN segment
- records sender/location pair in switch table

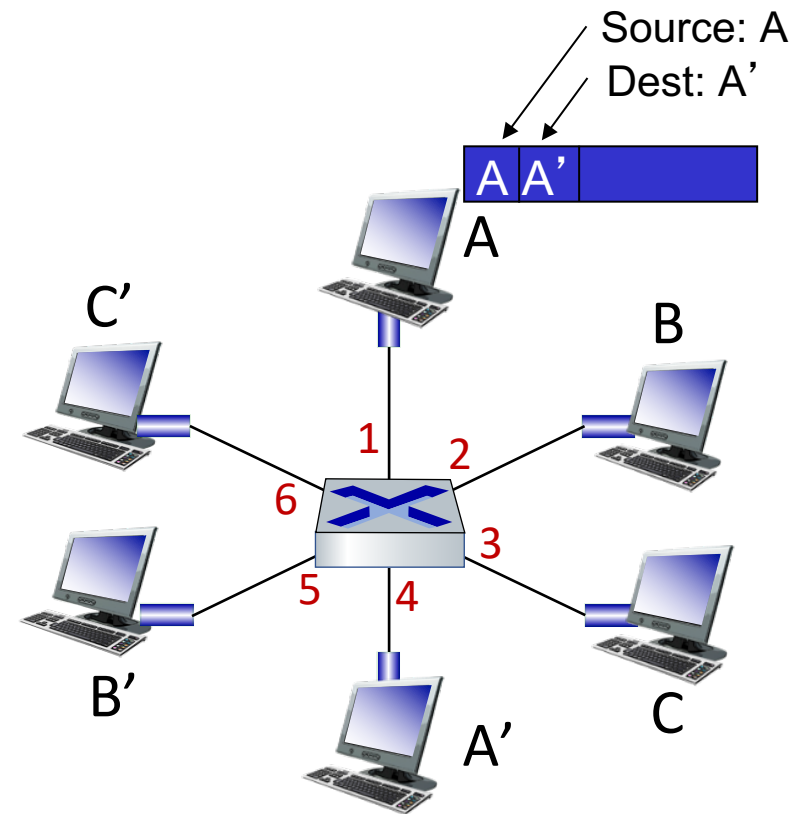

MAC addr	interface	TTL
A	1	60

*Switch table  
(initially empty)*

# Switch: frame filtering/forwarding

when frame received at switch:

1. record incoming link, MAC address of sending host
2. index switch table using MAC destination address
3. if entry found for destination  
then {  
if destination on segment from which frame arrived  
then drop frame  
else forward frame on interface indicated by entry  
}  
else flood /\* forward on all interfaces except arriving interface \*/

# Self-learning, forwarding: example

- frame destination, A', location unknown: **flood**
- destination A location known: **selectively send on just one link**

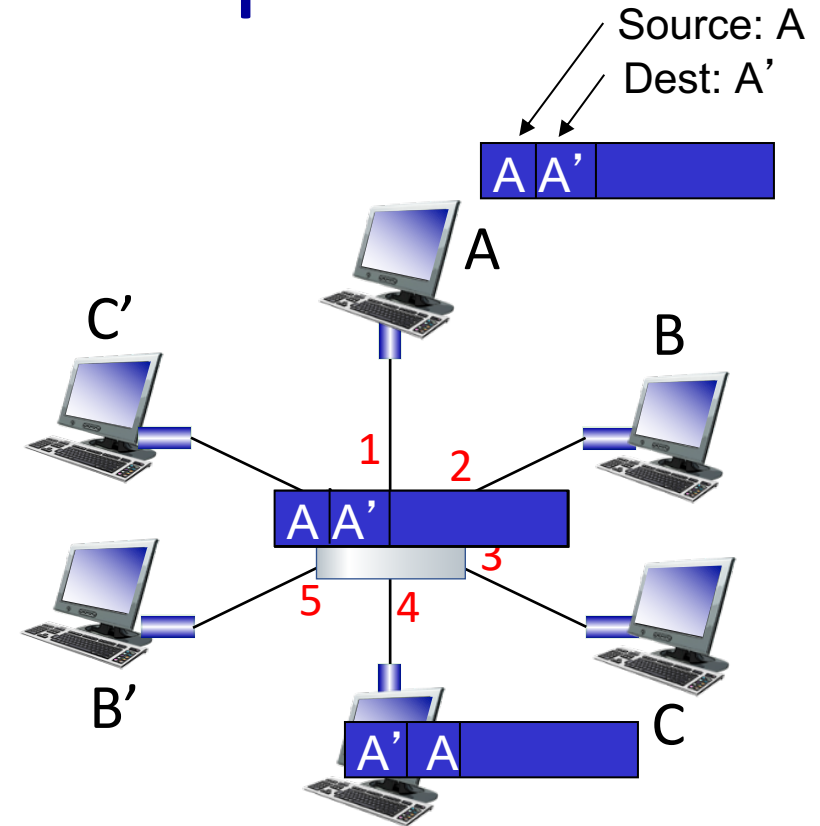

MAC addr	interface	TTL
A	1	60
A'	4	60

*switch table  
(initially empty)*

# Interconnecting switches

self-learning switches can be connected together:

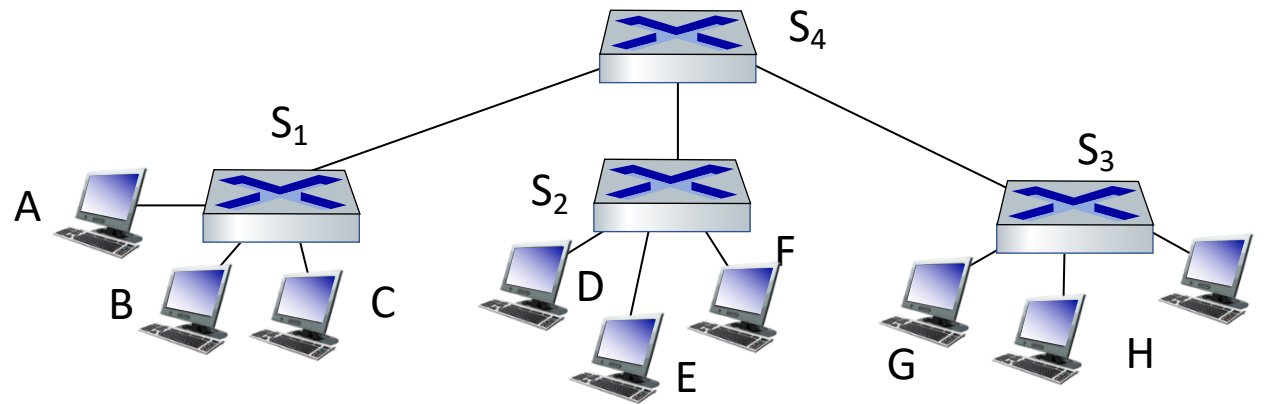

**Q:** sending from A to G - how does S<sub>1</sub> know to forward frame destined to G via S<sub>4</sub> and S<sub>3</sub>?

- **A:** self learning! (works exactly the same as in single-switch case!)

# Self-learning multi-switch example

Suppose C sends frame to I, I responds to C

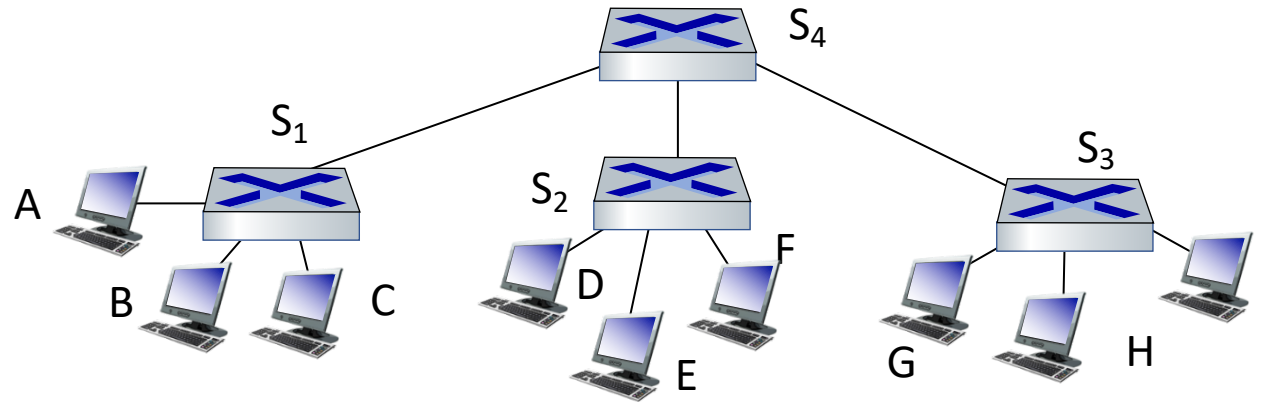

Q: show switch tables and packet forwarding in S<sub>1</sub>, S<sub>2</sub>, S<sub>3</sub>, S<sub>4</sub>

# UMass Campus Network - Detail

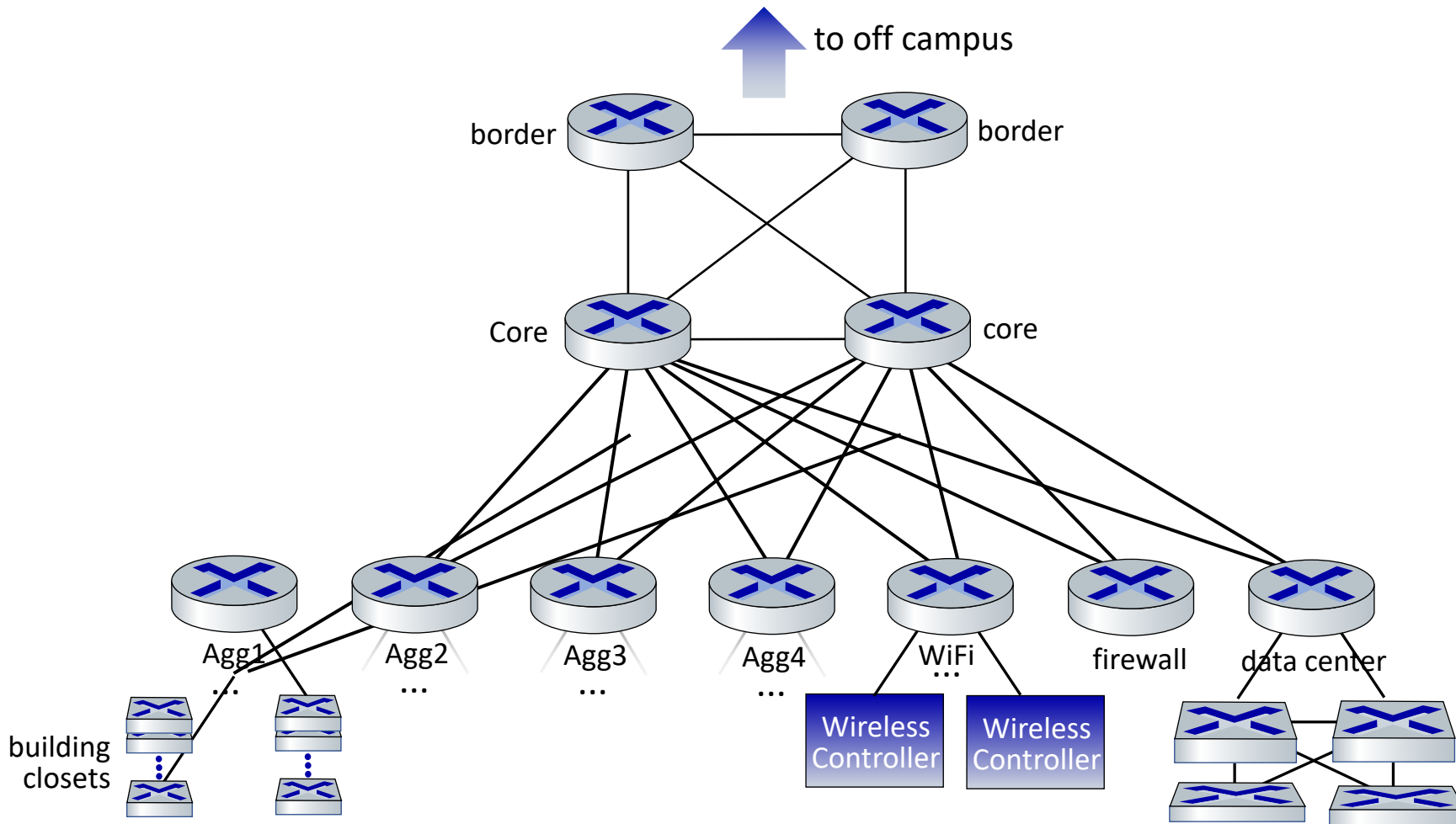

## UMass network:

- 4 firewalls
- 10 routers
- 2000+ network switches
- 6000 wireless access points
- 30000 active wired network jacks
- 55000 active end-user wireless devices

... all built, operated, maintained by ~15 people

# UMass Campus Network - Detail

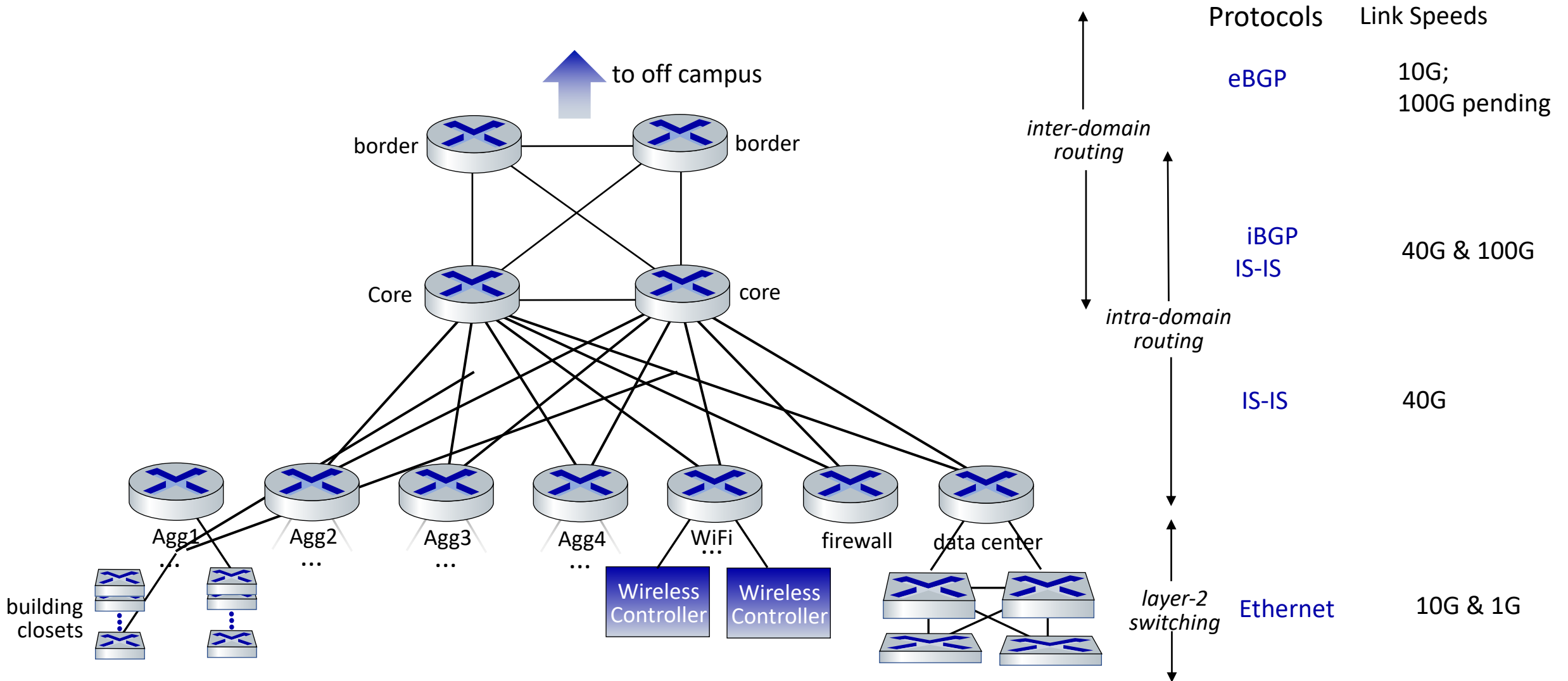

# Switches vs. routers

both are store-and-forward:

- *routers*: network-layer devices (examine network-layer headers)
- *switches*: link-layer devices (examine link-layer headers)

both have forwarding tables:

- *routers*: compute tables using routing algorithms, IP addresses
- *switches*: learn forwarding table using flooding, learning, MAC addresses

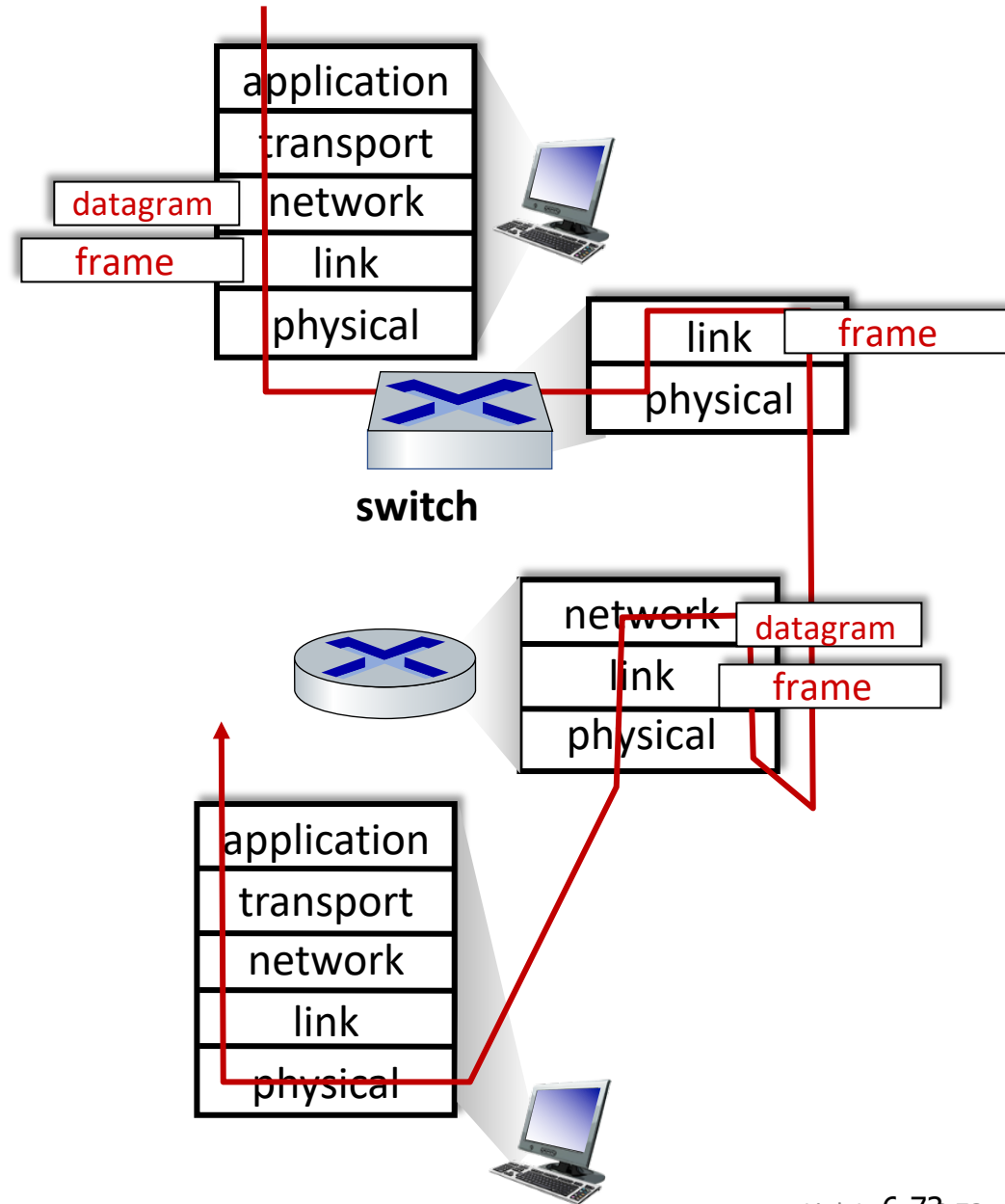

# Link layer, LANs: roadmap

- introduction
- error detection, correction
- multiple access protocols
- **LANs**
  - addressing, ARP
  - Ethernet
  - switches
  - **VLANs**
- link virtualization: MPLS
- data center networking



- a day in the life of a web request

# Virtual LANs (VLANs): motivation

Q: what happens as LAN sizes scale, users change point of attachment?

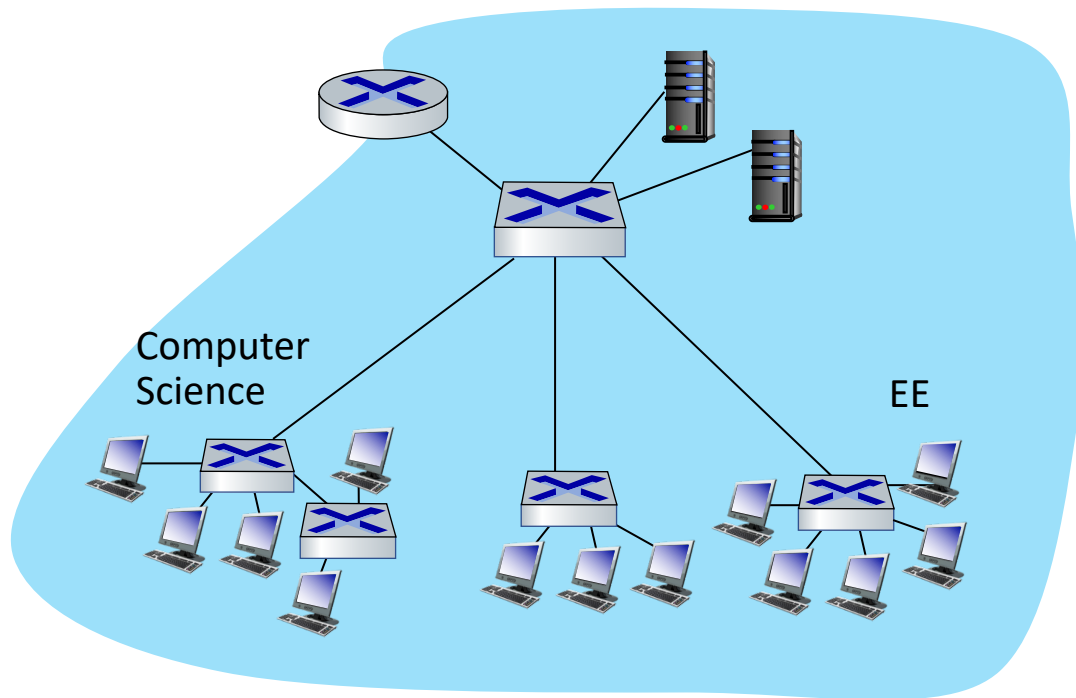

single broadcast domain:

- *scaling*: all layer-2 broadcast traffic (ARP, DHCP, unknown MAC) must cross entire LAN
- efficiency, security, privacy issues

# Virtual LANs (VLANs): motivation

Q: what happens as LAN sizes scale, users change point of attachment?

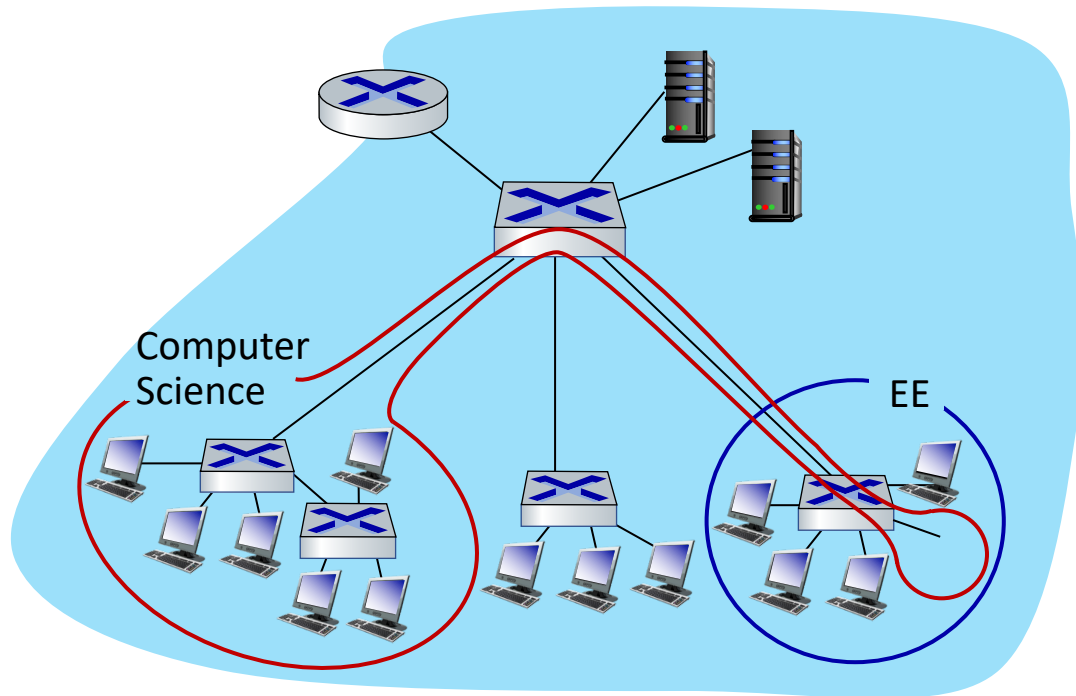

single broadcast domain:

- *scaling*: all layer-2 broadcast traffic (ARP, DHCP, unknown MAC) must cross entire LAN
- efficiency, security, privacy, efficiency issues

administrative issues:

- CS user moves office to EE - *physically* attached to EE switch, but wants to remain *logically* attached to CS switch

# Port-based VLANs

## Virtual Local Area Network (VLAN)

switch(es) supporting VLAN capabilities can be configured to define multiple *virtual* LANS over single physical LAN infrastructure.

**port-based VLAN:** switch ports grouped (by switch management software) so that *single* physical switch .....

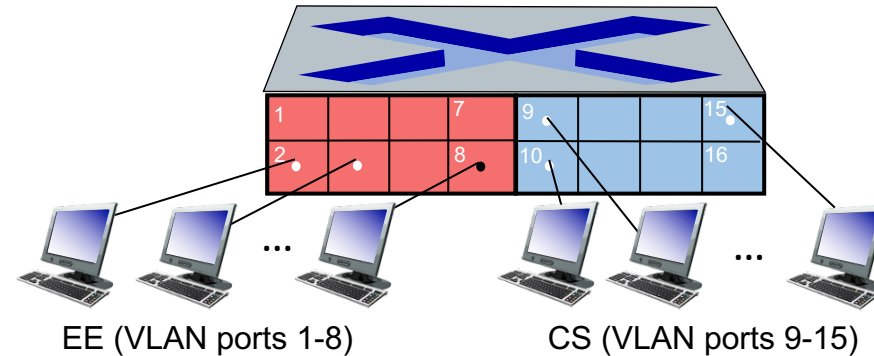

... operates as **multiple** virtual switches

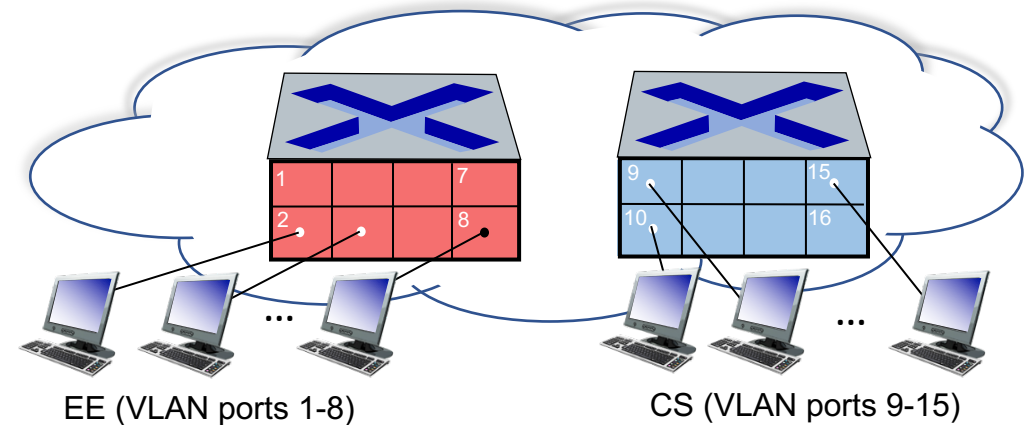

# Port-based VLANs

- **traffic isolation:** frames to/from ports 1-8 can *only* reach ports 1-8
  - can also define VLAN based on MAC addresses of endpoints, rather than switch port
- **dynamic membership:** ports can be dynamically assigned among VLANs
- **forwarding between VLANs:** done via routing (just as with separate switches)
  - in practice vendors sell combined switches plus routers

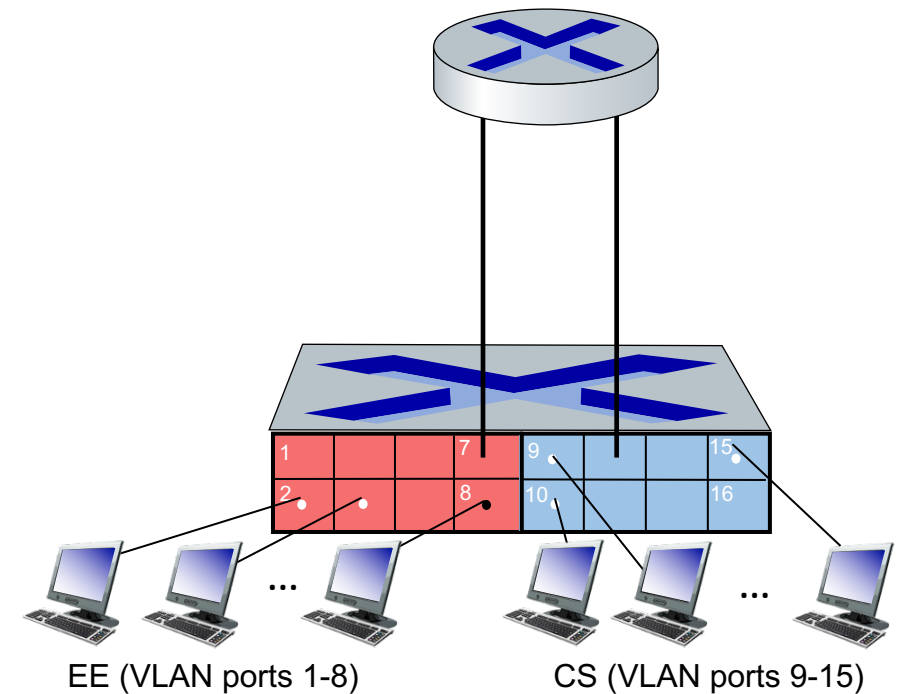

# VLANs spanning multiple switches

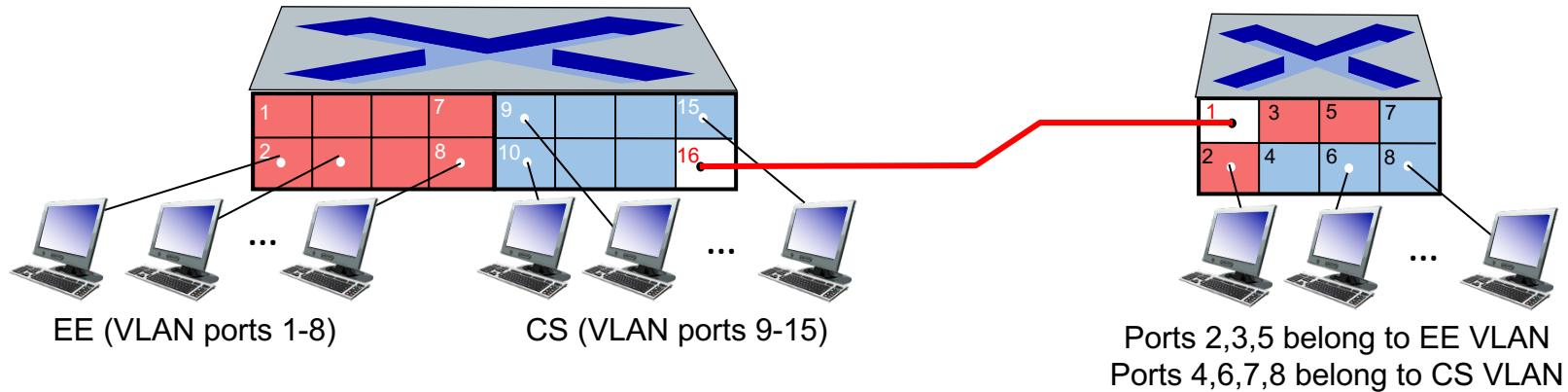

**trunk port:** carries frames between VLANs defined over multiple physical switches

- frames forwarded within VLAN between switches can't be vanilla 802.1 frames (must carry VLAN ID info)
- 802.1q protocol adds/removed additional header fields for frames forwarded between trunk ports

# 802.1Q VLAN frame format

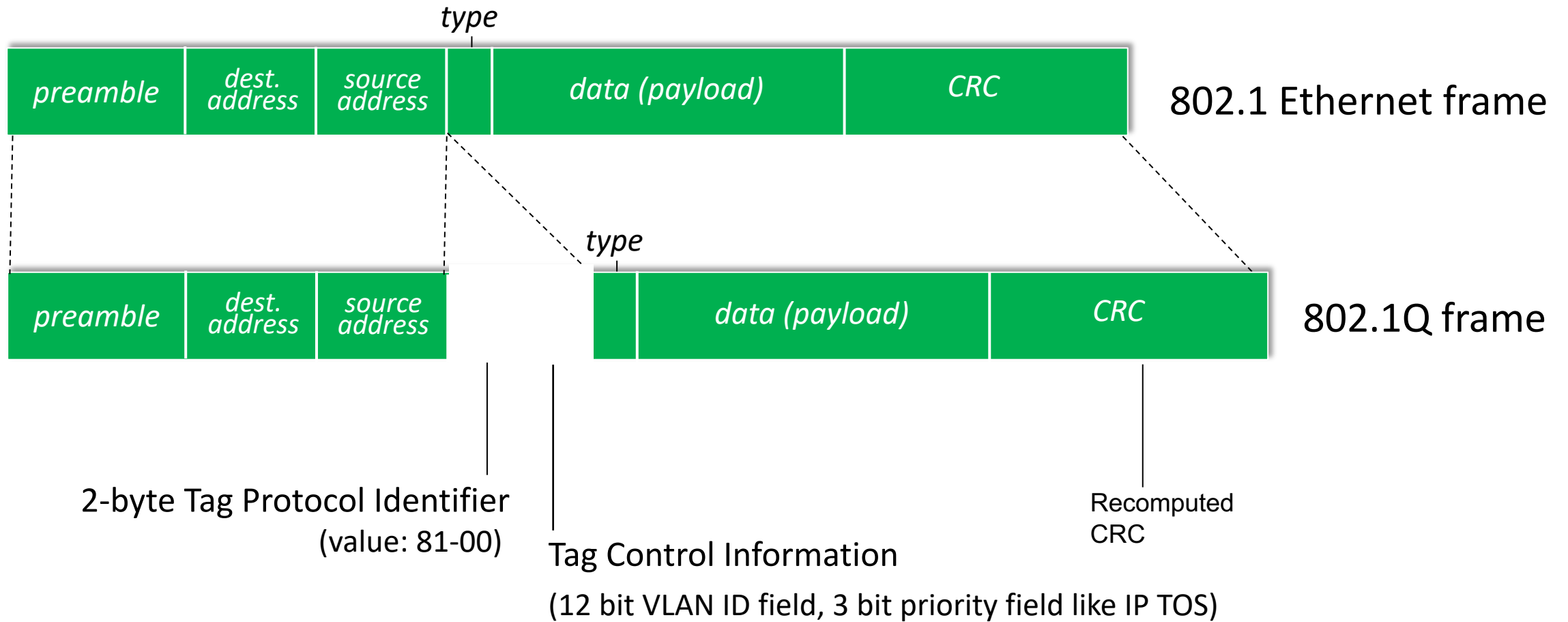

# EVPN: Ethernet VPNs (aka VXLANs)

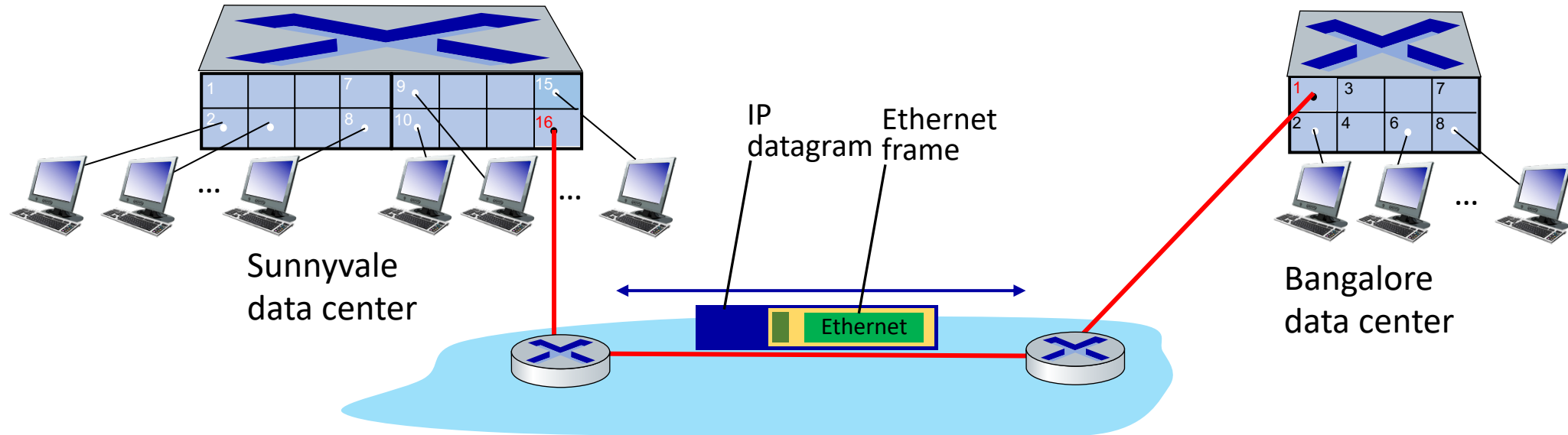

Layer-2 Ethernet switches *logically* connected to each other (e.g., using IP as an *underlay*)

- Ethernet frames carried *within* IP datagrams between sites
- “*tunneling* scheme to *overlay Layer 2 networks on top of Layer 3 networks* ... runs over the existing networking infrastructure and provides a means to “stretch” a Layer 2 network.” [RFC 7348]

# EVPN: Ethernet VPNs (aka VXLANs)

Layer-2 Ethernet switches *logically* connected to each other (using IP as an *underlay*)

- Ethernet frames carried *within* IP datagrams between sites
- “*tunneling* scheme to *overlay Layer 2 networks on top of Layer 3 networks* ... runs over existing networking infrastructure ... provides a means to “stretch” a Layer 2 network.” [RFC 7348]

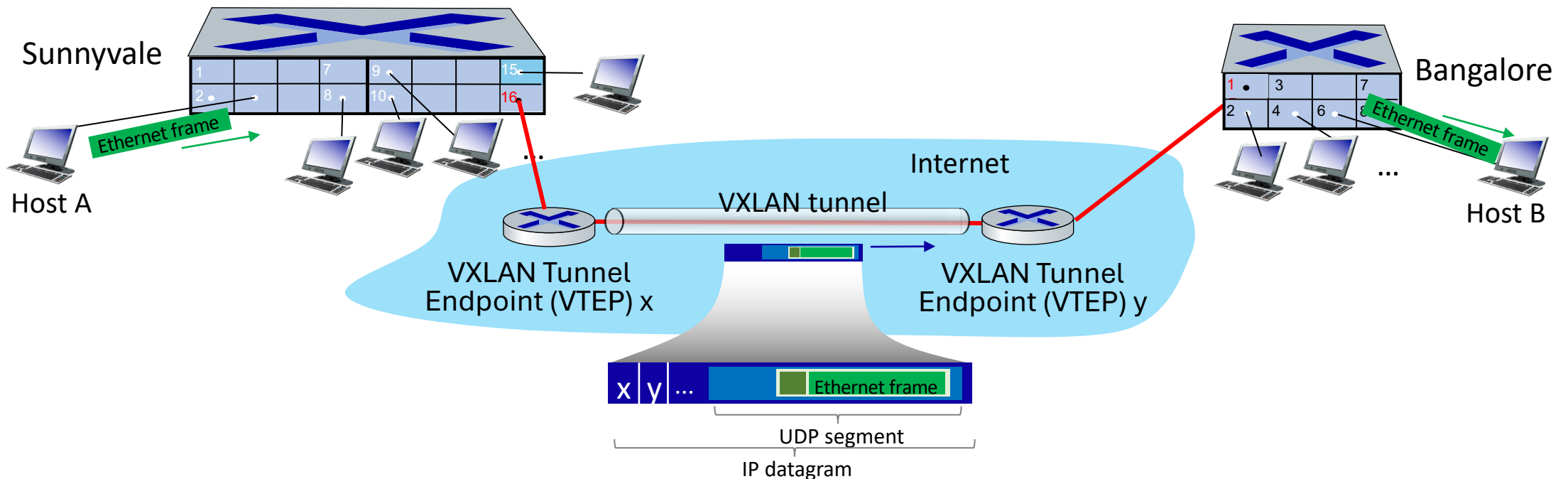

# Link layer, LANs: roadmap

- introduction
- error detection, correction
- multiple access protocols
- LANs
  - addressing, ARP
  - Ethernet
  - switches
  - VLANs
- **link virtualization: MPLS**
- data center networking



- a day in the life of a web request

# Multiprotocol label switching (MPLS)

- **goal:** high-speed IP forwarding among network of MPLS-capable routers, using fixed length label (instead of shortest prefix matching)
  - faster lookup using fixed length identifier
  - borrowing ideas from Virtual Circuit (VC) approach
  - but IP datagram still keeps IP address!

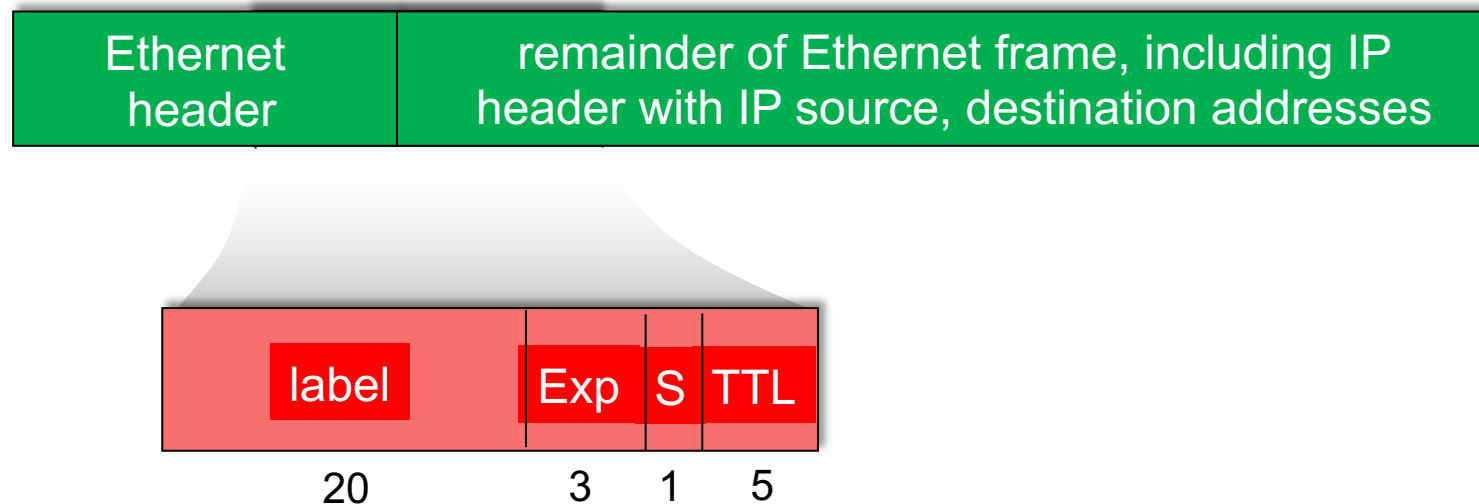

# MPLS capable routers

- a.k.a. label-switched router
- forward packets to outgoing interface based only on label value (*don't inspect IP address*)
  - MPLS forwarding table distinct from IP forwarding tables
- *flexibility*: MPLS forwarding decisions can *differ* from those of IP
  - use destination *and* source addresses to route flows to same destination differently (traffic engineering)
  - re-route flows quickly if link fails: pre-computed backup paths

# MPLS versus IP paths

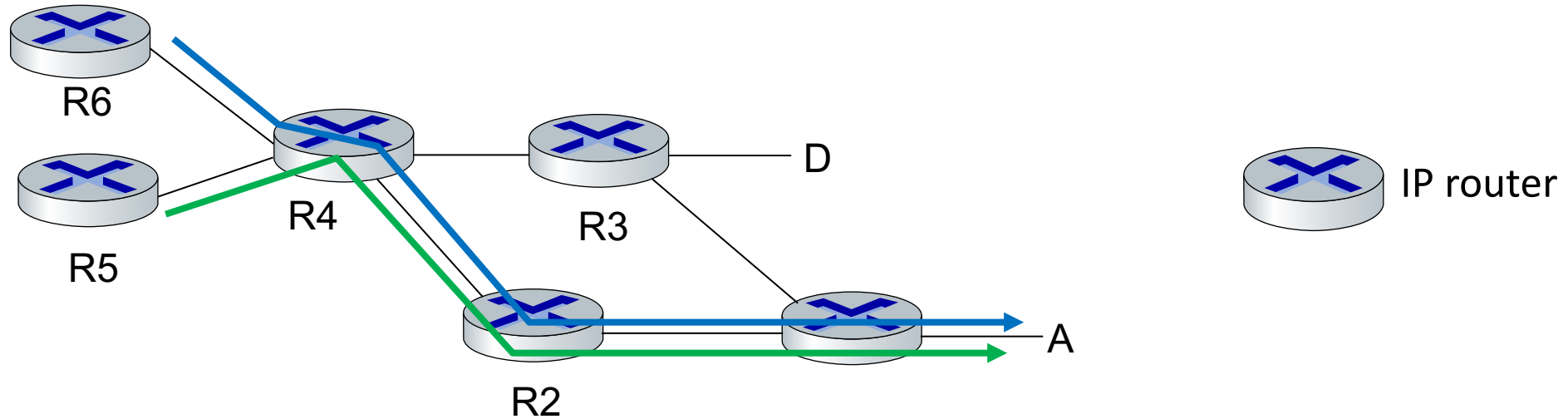

- **IP routing:** path to destination determined by destination address alone

# MPLS versus IP paths

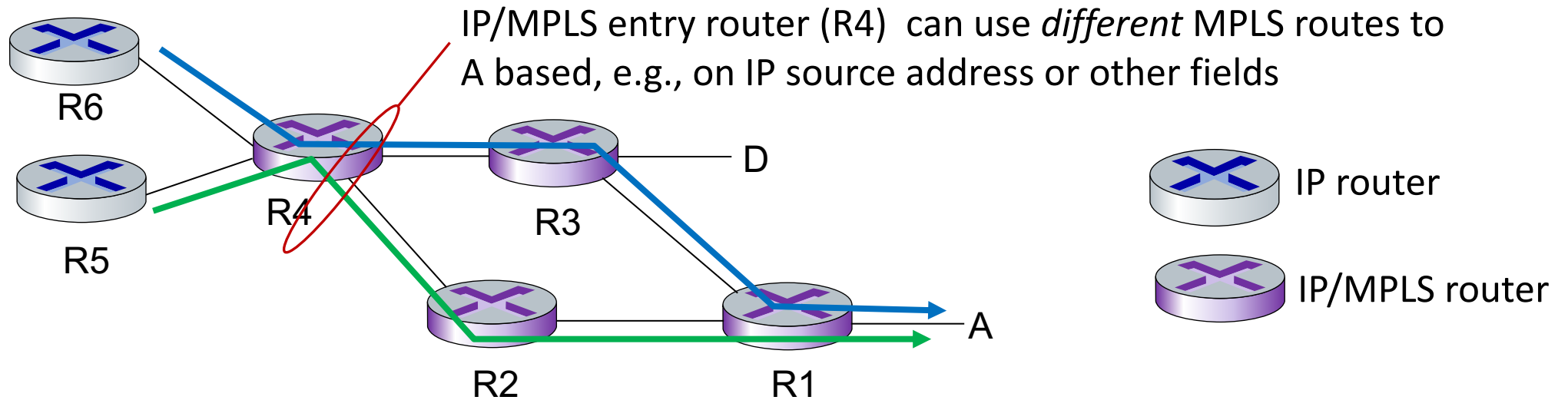

- **IP routing:** path to destination determined by destination address alone
- **MPLS routing:** path to destination can be based on source *and* destination address
  - flavor of generalized forwarding (MPLS 10 years earlier)
  - *fast reroute:* precompute backup routes in case of link failure

# MPLS signaling

- modify OSPF, IS-IS link-state flooding protocols to carry info used by MPLS routing:
  - e.g., link bandwidth, amount of “reserved” link bandwidth
- entry MPLS router uses RSVP-TE signaling protocol to set up MPLS forwarding at downstream routers

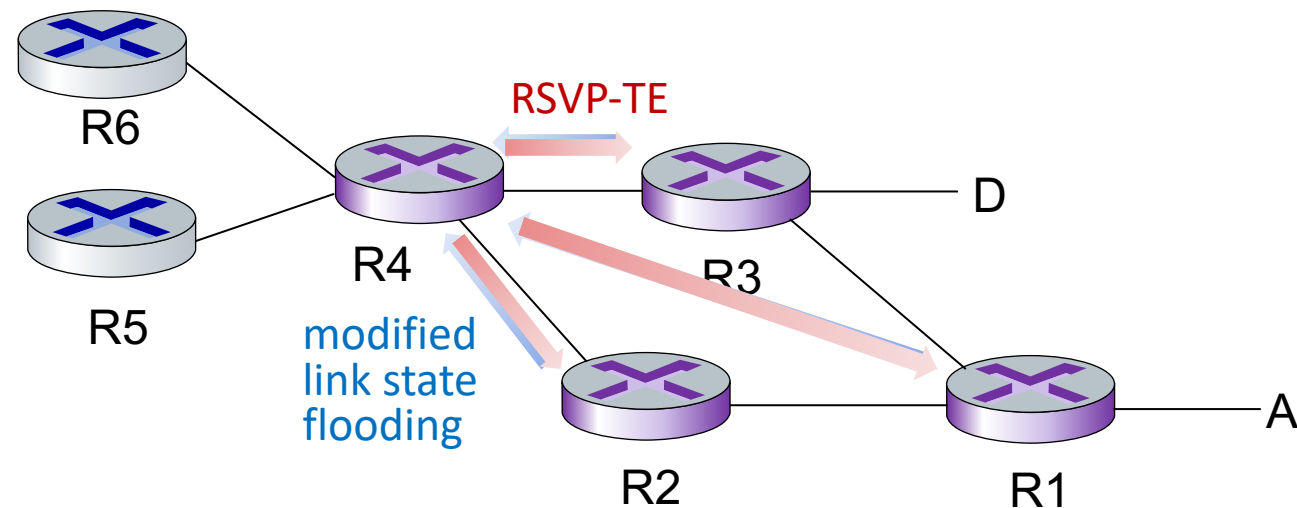

# MPLS forwarding tables

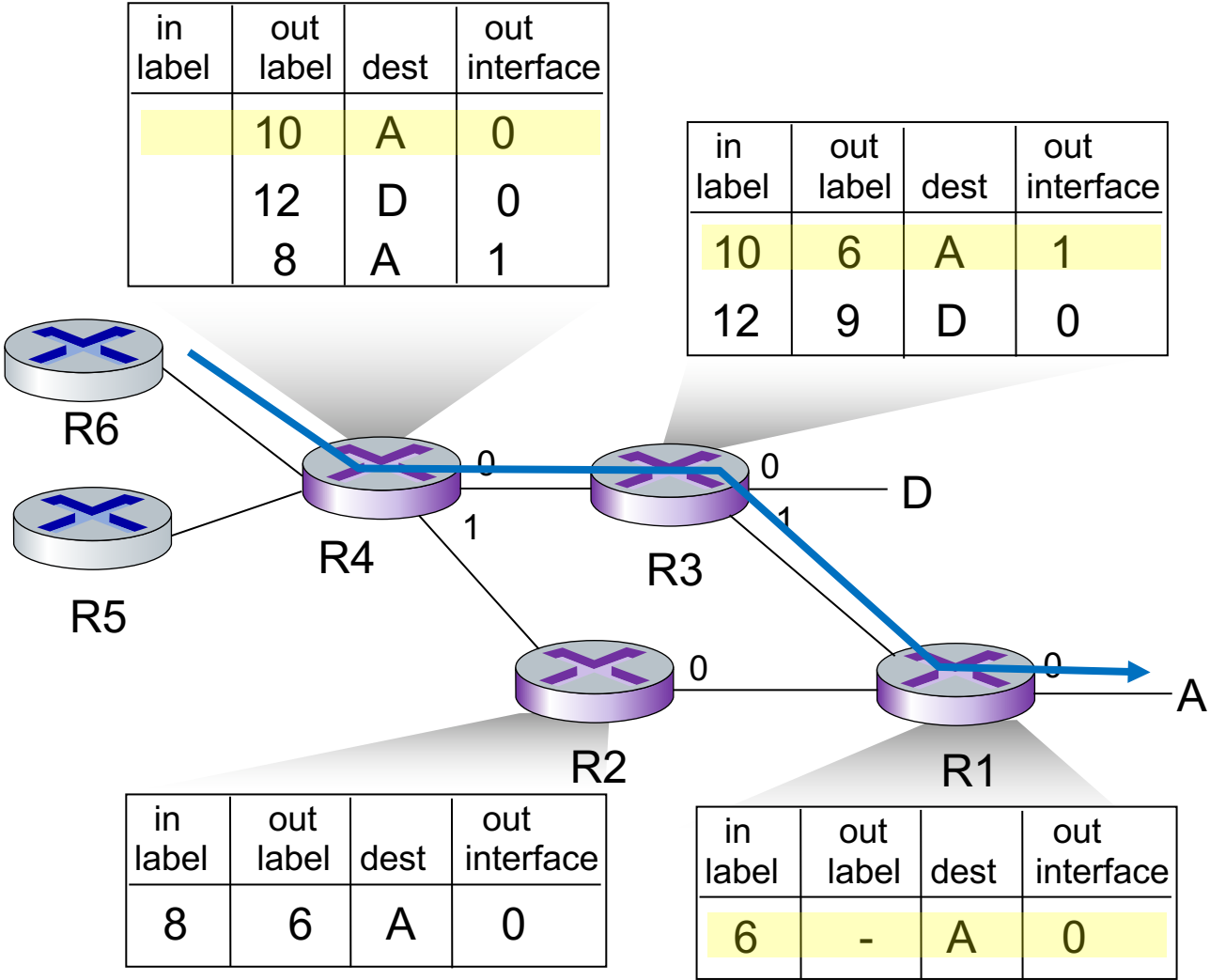

# Link layer, LANs: roadmap

- introduction
- error detection, correction
- multiple access protocols
- LANs
  - addressing, ARP
  - Ethernet
  - switches
  - VLANs
- link virtualization: MPLS
- data center networking



- a day in the life of a web request

# Datacenter networks

10's to 100's of thousands of hosts, often closely coupled, in close proximity:

- e-business (e.g. Amazon)
- content-servers (e.g., YouTube, Akamai, Apple, Microsoft)
- search engines, data mining (e.g., Google)

challenges:

- multiple applications, each serving massive numbers of clients
- reliability
- managing/balancing load, avoiding processing, networking, data bottlenecks



Inside a 40-ft Microsoft container, Chicago data center

# Datacenter networks: network elements

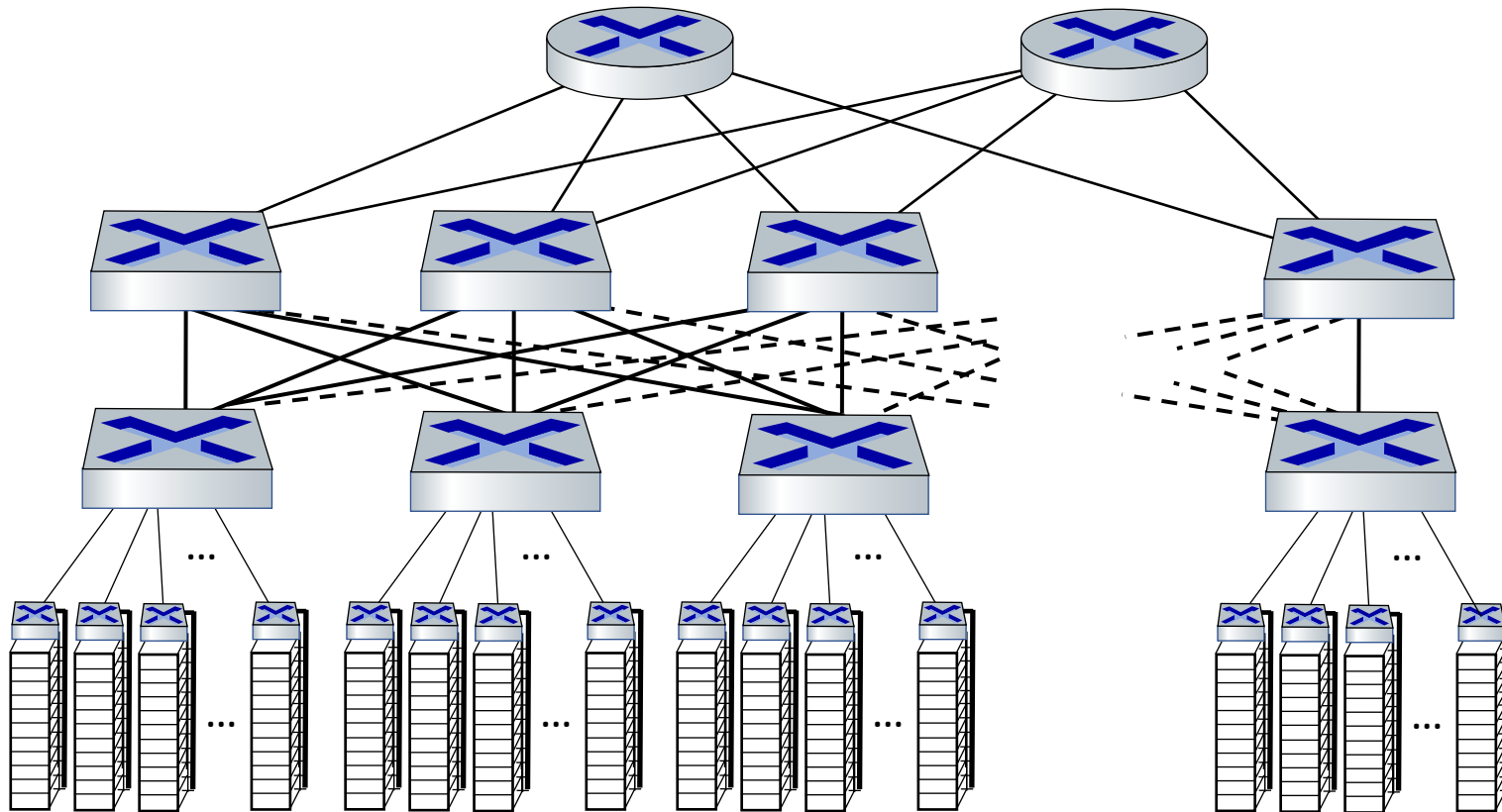

## Border routers

- connections outside datacenter

## Tier-1 (Core) switches

- connecting to ~16 T-2s below

## Tier-2 (Aggregation) switches

- connecting to ~16 TORs below

## Top of Rack (TOR) (Access) switches

- one per rack, 100G-400G Ethernet to blades

## Server racks

- 20- 40 server blades: hosts

# Datacenter networks: network elements

Two-layer leaf/spline datacenter interconnection network:

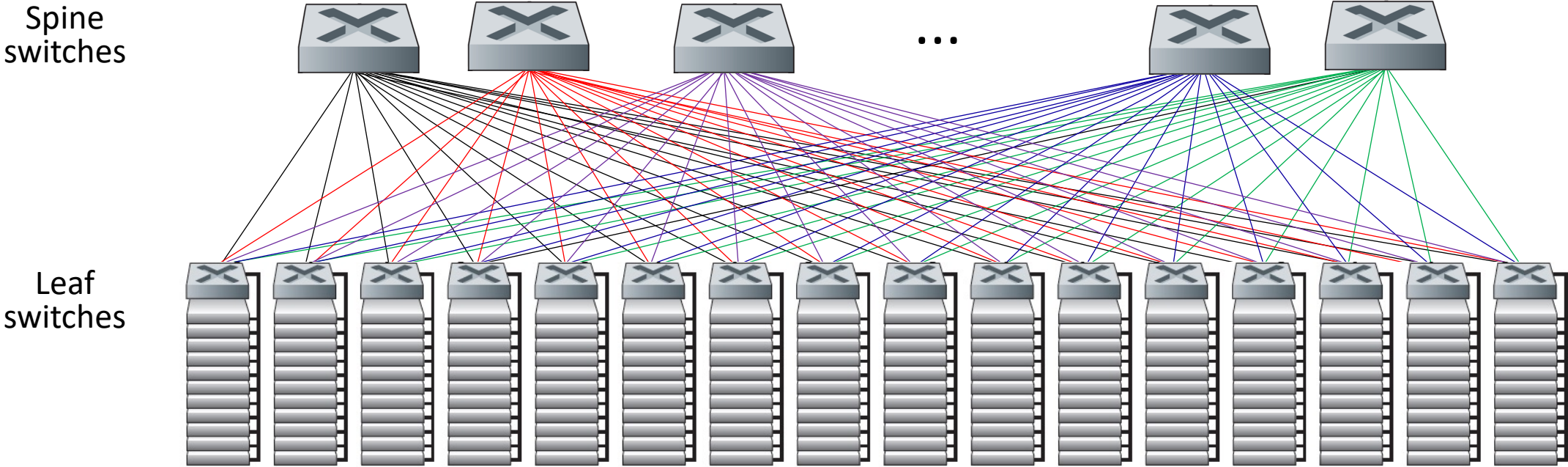

# Facebook Datacenter network

Facebook F16 data center network topology:

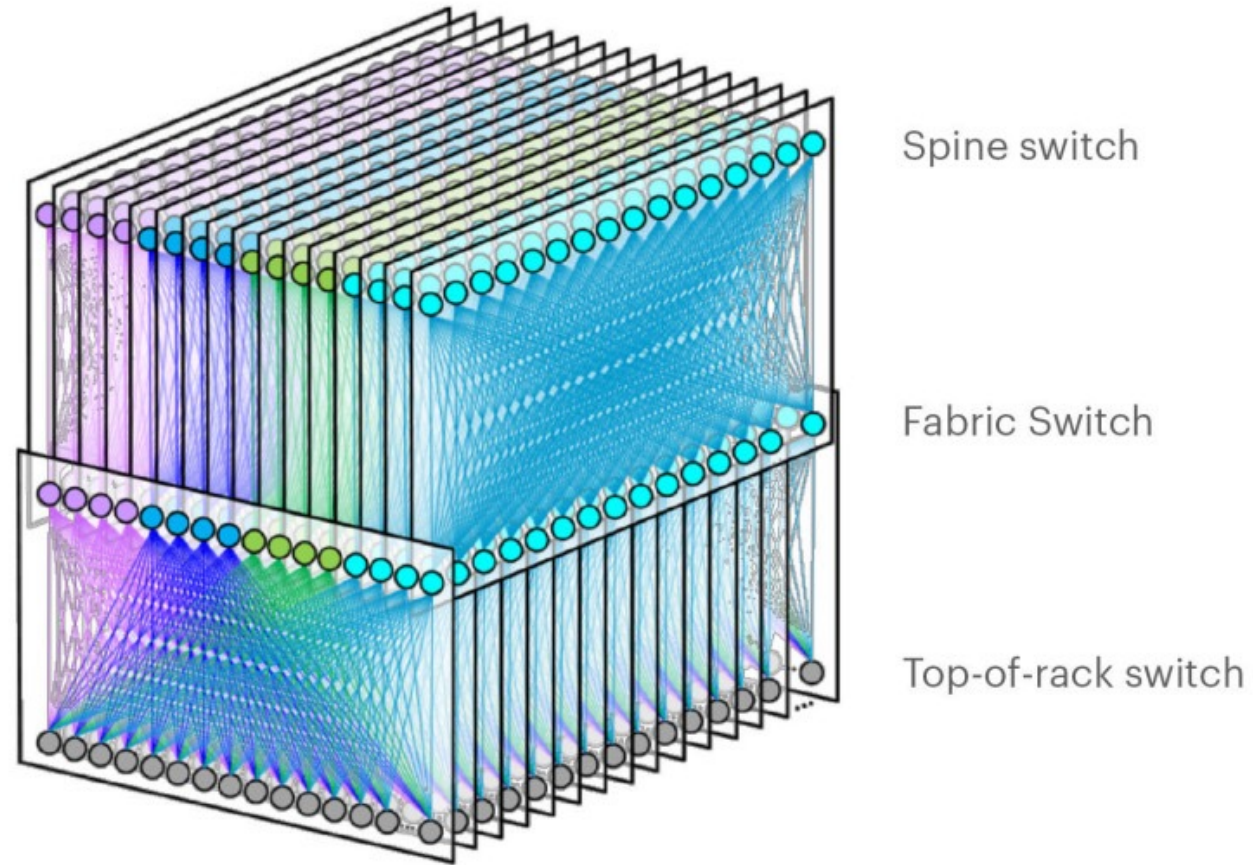

<https://engineering.fb.com/data-center-engineering/f16-minipack/> (posted 3/2019)

# Datacenter networks: multipath

- rich interconnection among switches, racks:
  - increased throughput between racks (multiple routing paths possible)
  - increased reliability via redundancy

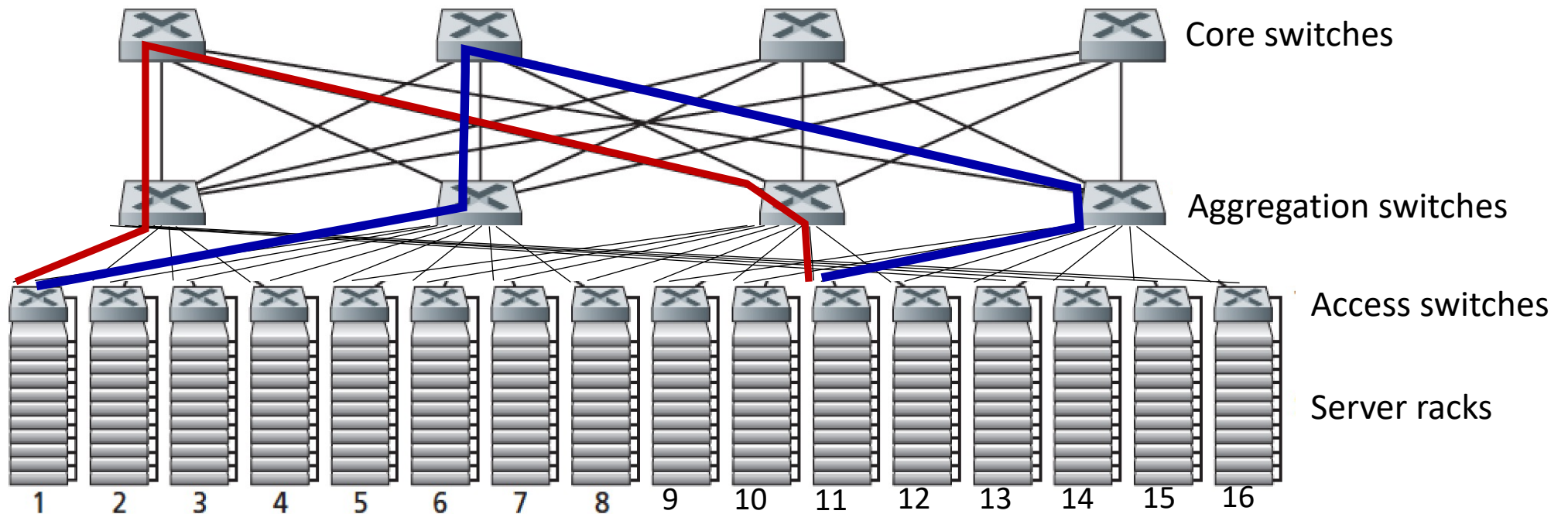

two **disjoint** paths highlighted between racks 1 and 11

# Datacenter networks: application-layer routing

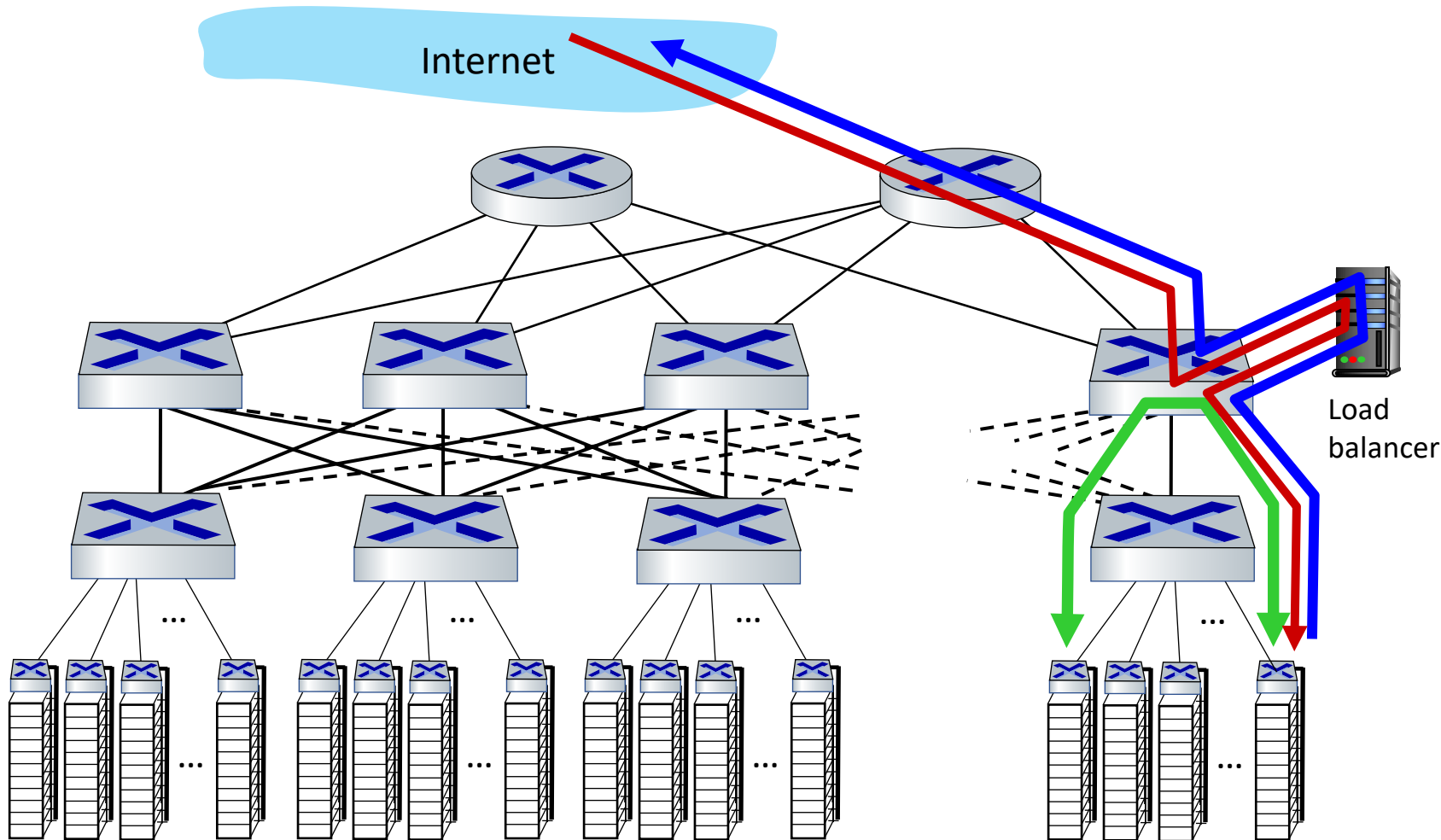

## load balancer: application-layer routing

- receives external client requests
- directs workload within data center
- returns results to external client (hiding data center internals from client)

# Datacenter networks: protocol innovations

## ■ link layer:

- RoCE: remote DMA (RDMA) over Converged Ethernet

## ■ transport layer:

- ECN (explicit congestion notification) used in transport-layer congestion control (DCTCP, DCQCN)
- experimentation with hop-by-hop (backpressure) congestion control

## ■ routing, management:

- SDN widely used within/among organizations' datacenters
- place related services, data as close as possible (e.g., in same rack or nearby rack) to minimize tier-2, tier-1 communication

# ORION: Google's new SDN control plane for internal datacenter (Jupiter) + wide area (B4) network

- **routing** (intradomain, iBGP), traffic engineering: implemented in *applications* on top of ORION core
- **edge-edge flow-based** controls (e.g., CoFlow scheduling) to meet contract SLAs
- **management**: pub-sub distributed microservices in Orion core, OpenFlow for switch signaling/monitoring

## Note:

- no routing protocols, congestion control (partially) also managed by SDN rather than by protocol
- are protocols dying?

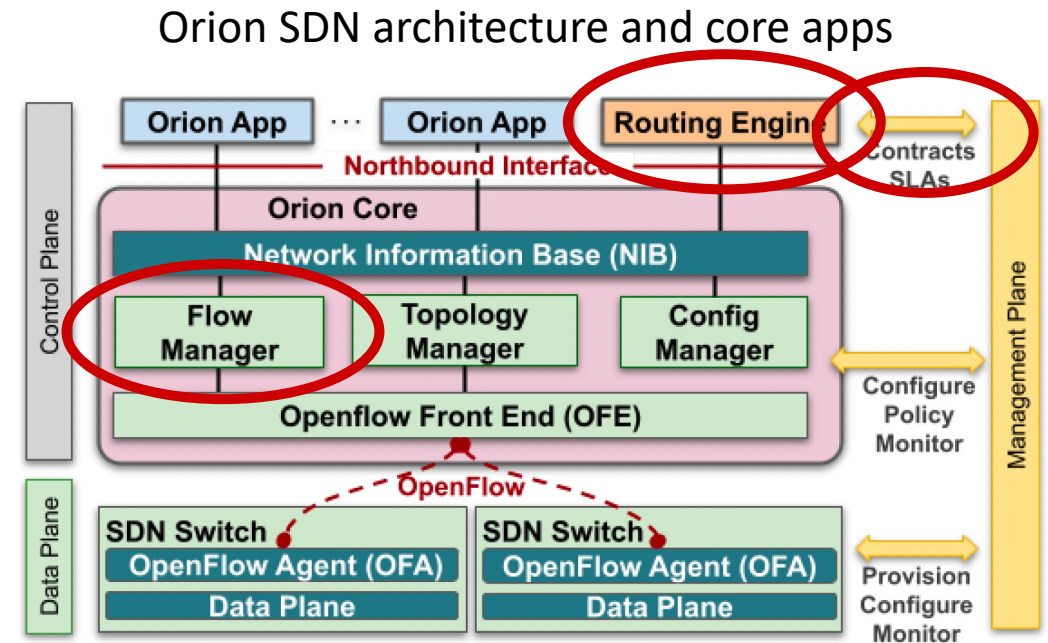

# Link layer, LANs: roadmap

- introduction
- error detection, correction
- multiple access protocols
- LANs
  - addressing, ARP
  - Ethernet
  - switches
  - VLANs
- link virtualization: MPLS
- data center networking



- a day in the life of a web request

# Synthesis: a day in the life of a web request

- our journey down the protocol stack is now complete!
  - application, transport, network, link
- putting-it-all-together: synthesis!
  - *goal*: identify, review, understand protocols (at all layers) involved in seemingly simple scenario: requesting www page
  - *scenario*: student attaches laptop to campus network, requests/receives [www.google.com](http://www.google.com)

# A day in the life: scenario

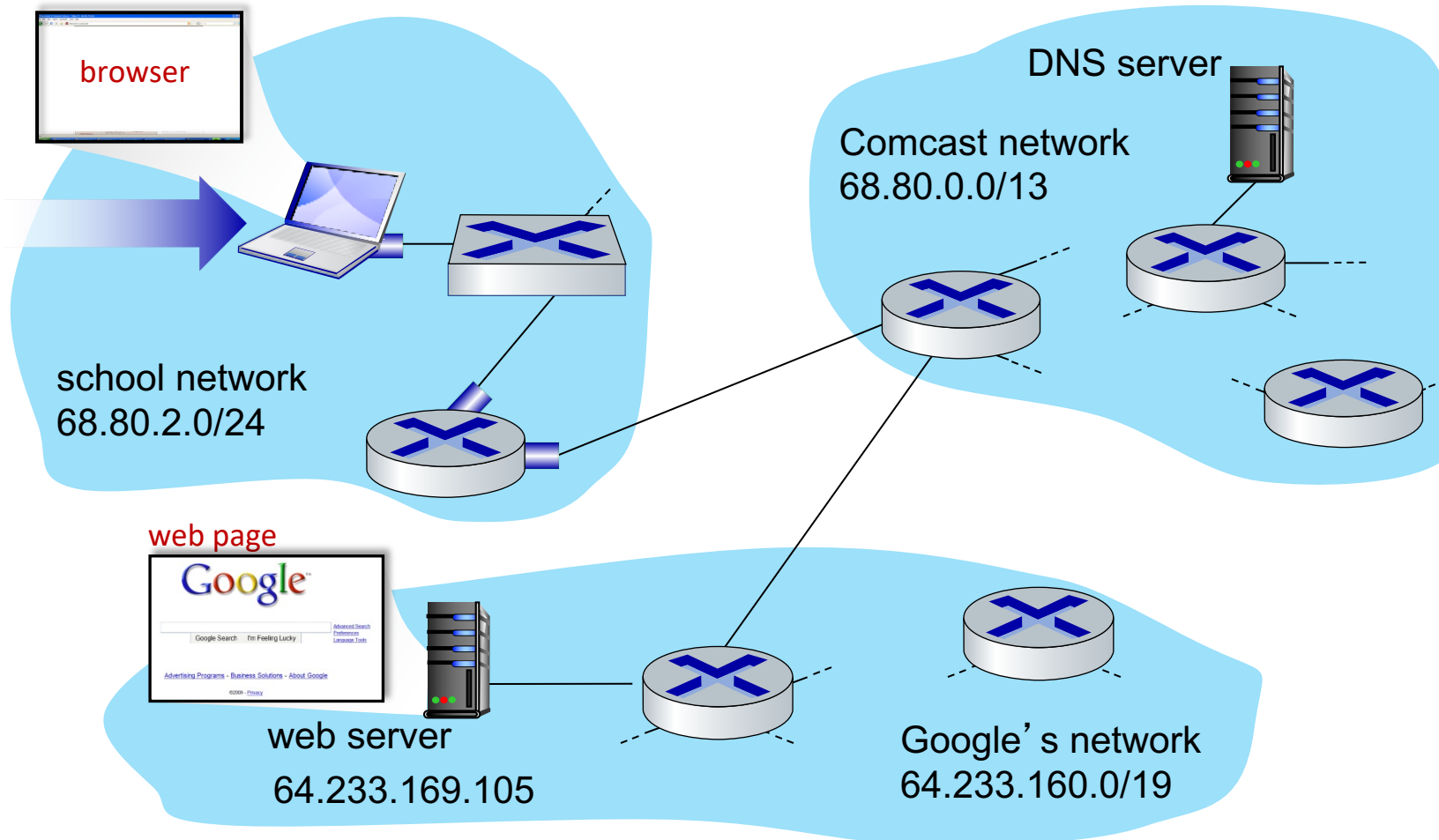

scenario:

- arriving mobile client attaches to network ...
- requests web page:  
www.google.com

*Sounds simple!* 

# A day in the life: connecting to the Internet

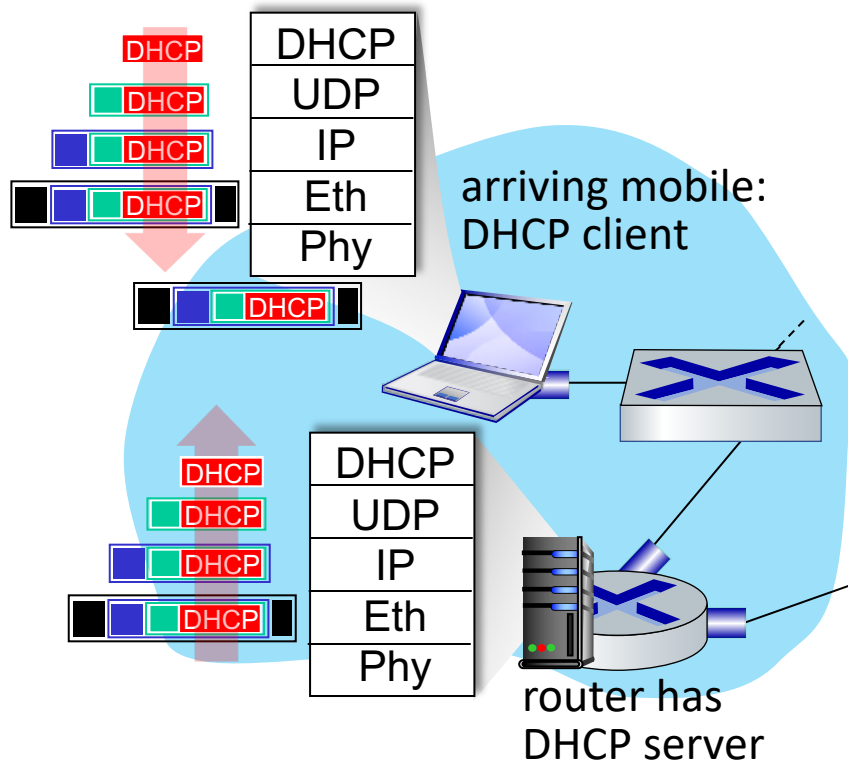

- connecting laptop needs to get its own IP address, addr of first-hop router, addr of DNS server: use **DHCP**
- DHCP request **encapsulated** in **UDP**, encapsulated in **IP**, encapsulated in **802.3** Ethernet
- Ethernet frame **broadcast** (dest: FFFFFFFFFFFFFFFF) on LAN, received at router running **DHCP** server
- Ethernet **de-muxed** to IP de-muxed, UDP de-muxed to DHCP

# A day in the life: connecting to the Internet

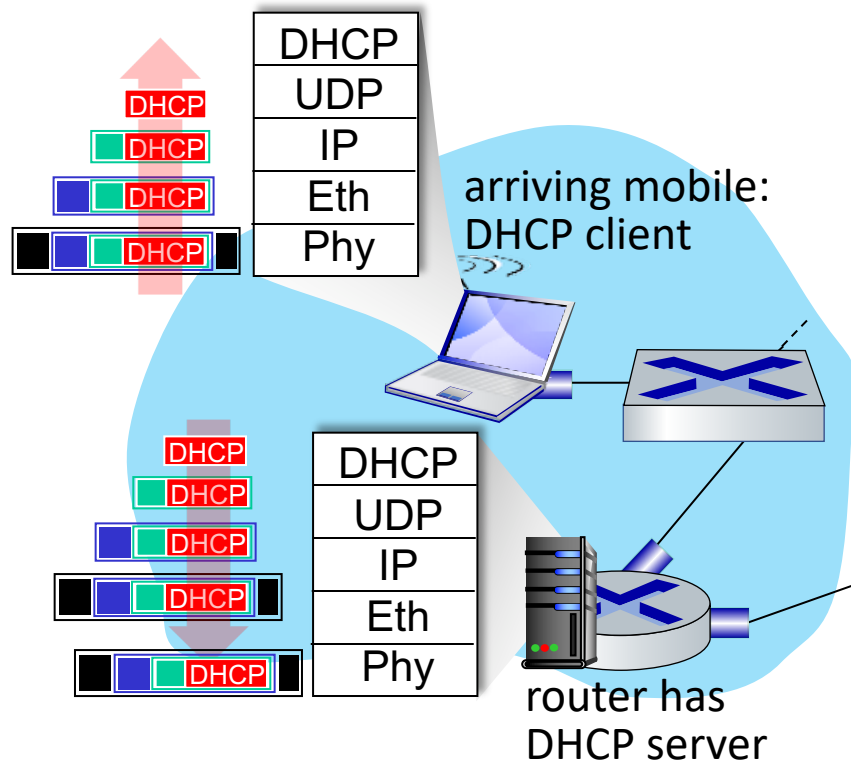

- DHCP server formulates **DHCP ACK** containing client's IP address, IP address of first-hop router for client, name & IP address of DNS server
- encapsulation at DHCP server, frame forwarded (**switch learning**) through LAN, demultiplexing at client
- DHCP client receives DHCP ACK reply

*Client now has IP address, knows name & addr of DNS server, IP address of its first-hop router*

# A day in the life... ARP (before DNS, before HTTP)

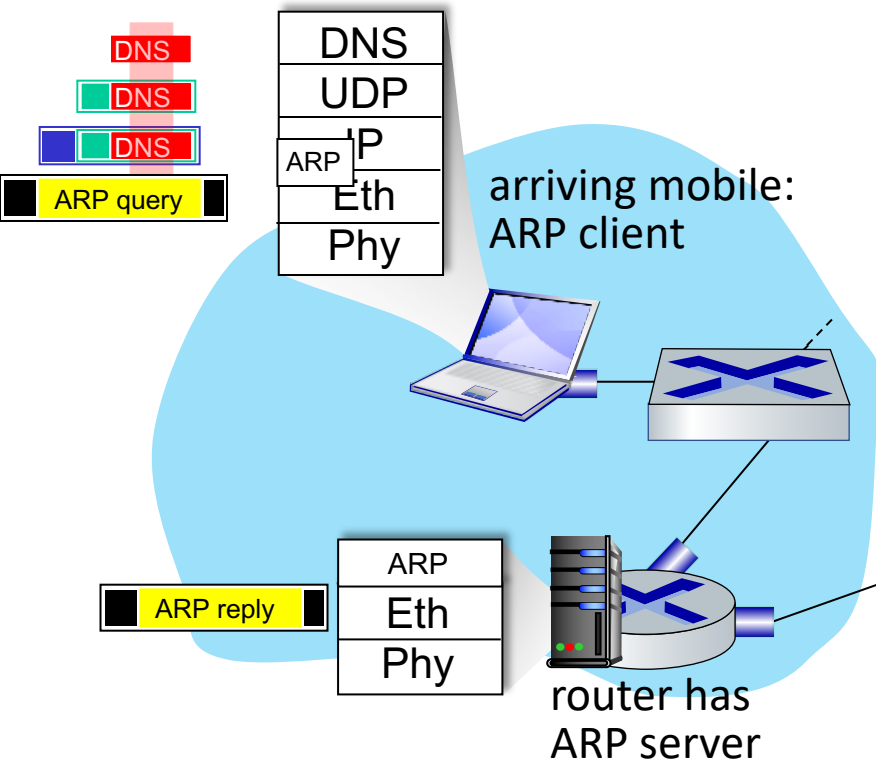

- before sending **HTTP** request, need IP address of `www.google.com`: **DNS**
- DNS query created, encapsulated in UDP, encapsulated in IP, encapsulated in Eth. To send frame to router, need MAC address of router interface: **ARP**
- **ARP query** broadcast, received by router, which replies with **ARP reply** giving MAC address of router interface
- client now knows MAC address of first hop router, so can now send frame containing DNS query

# A day in the life... using DNS

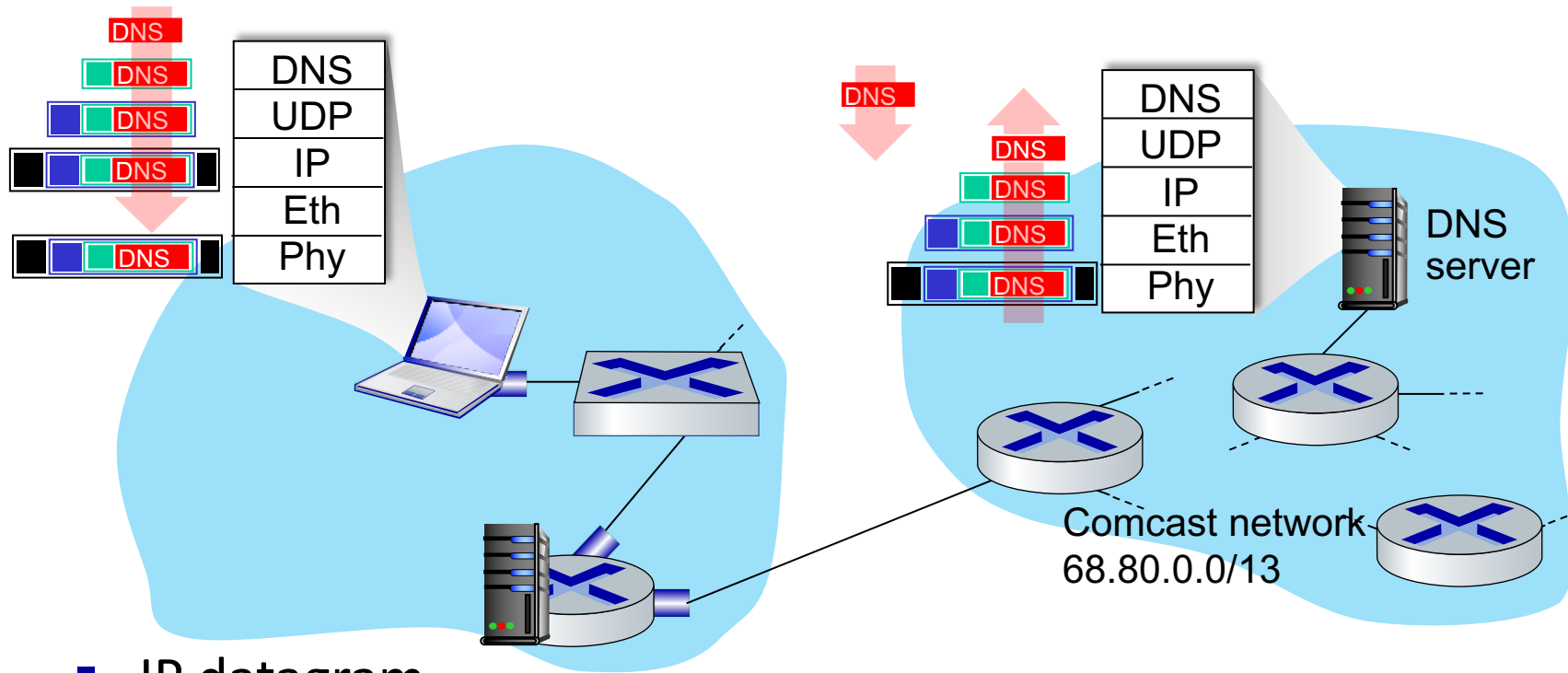

- IP datagram containing DNS query forwarded via LAN switch from client to 1<sup>st</sup> hop router

- IP datagram forwarded from campus network into Comcast network, routed (tables created by **RIP**, **OSPF**, **IS-IS** and/or **BGP** routing protocols) to DNS server

- de-muxed to DNS
- DNS replies to client with IP address of [www.google.com](http://www.google.com)

# A day in the life...TCP connection carrying HTTP

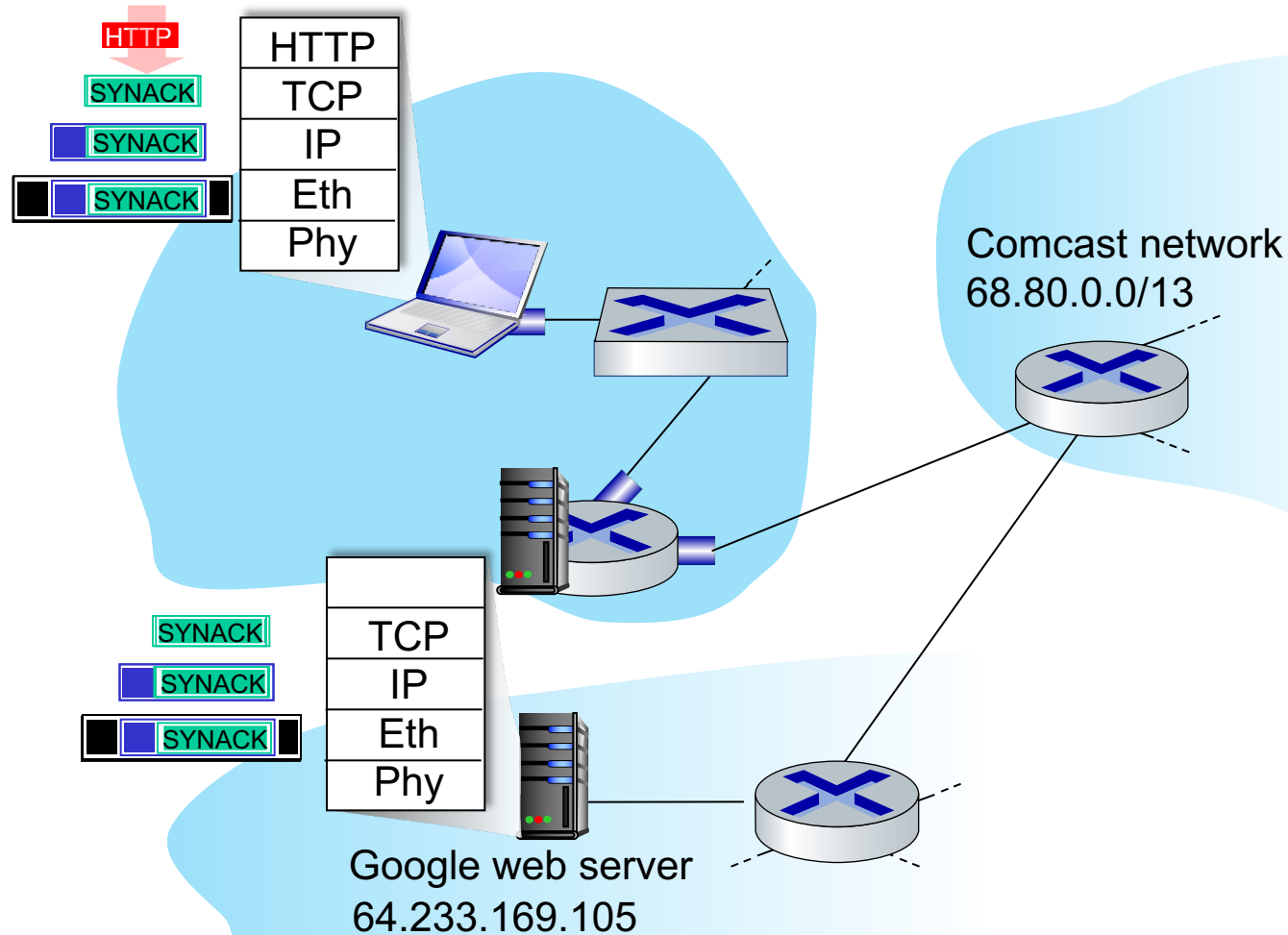

- to send HTTP request, client first opens **TCP socket** to web server
- TCP **SYN segment** (step 1 in TCP 3-way handshake) inter-domain routed to web server
- web server responds with **TCP SYNACK** (step 2 in TCP 3-way handshake)
- TCP **connection established!**

# A day in the life... HTTP request/reply

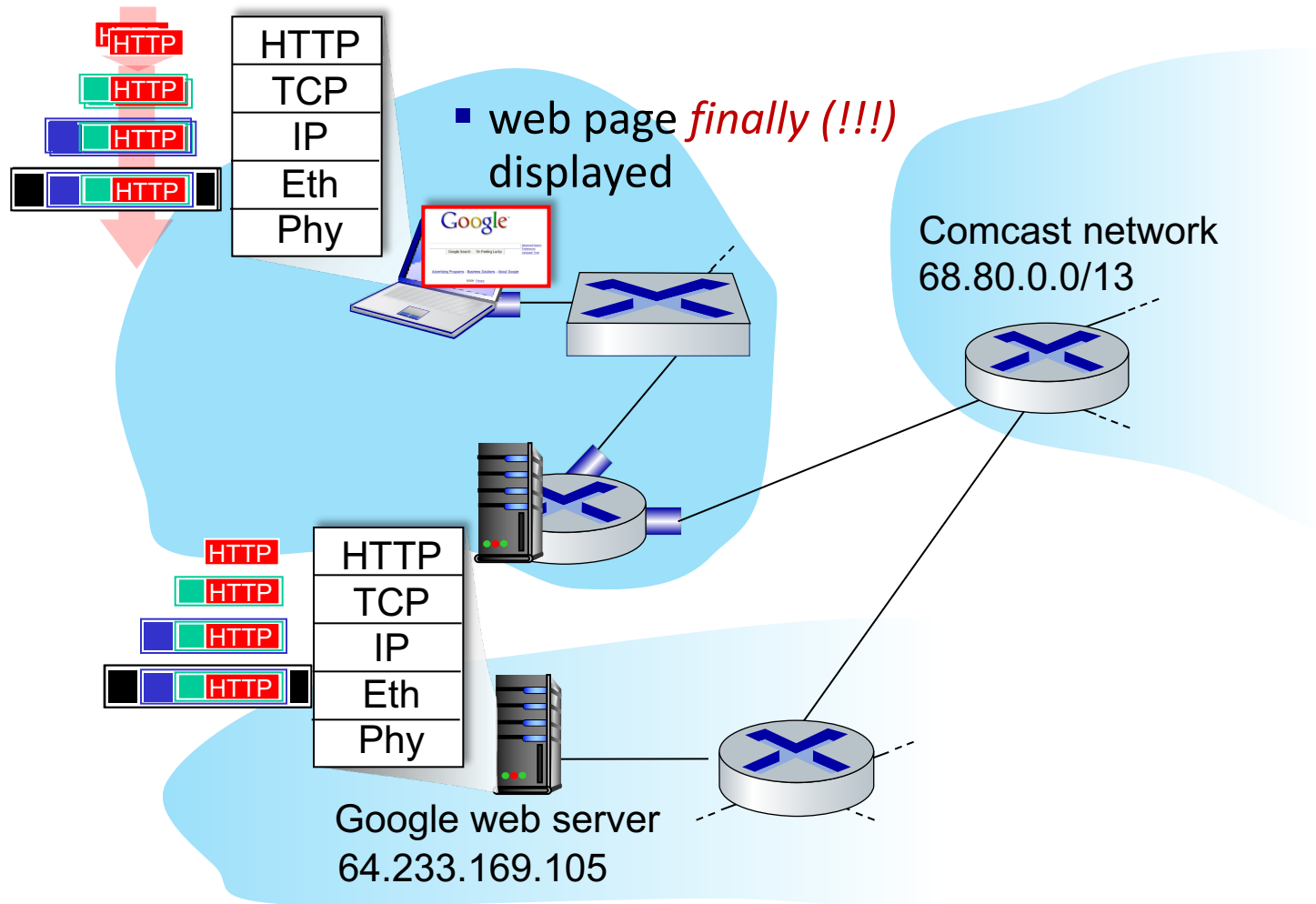

- HTTP request sent into TCP socket
- IP datagram containing HTTP request routed to www.google.com
- web server responds with HTTP reply (containing web page)
- IP datagram containing HTTP reply routed back to client

# Chapter 6: Summary

- principles behind data link layer services:
  - error detection, correction
  - sharing a broadcast channel: multiple access
  - link layer addressing
- instantiation, implementation of various link layer technologies
  - Ethernet
  - switched LANS, VLANs
  - virtualized networks as a link layer: MPLS
- synthesis: a day in the life of a web request

# Chapter 6: let's take a breath

- journey down protocol stack *complete* (except PHY)
- solid understanding of networking principles, practice!
- ..... could stop here ... but *more* interesting topics!
  - wireless
  - security

# Additional Chapter 6 slides

# Pure ALOHA efficiency

$P(\text{success by given node}) = P(\text{node transmits}) *$

$P(\text{no other node transmits in } [t_0-1, t_0] * *$

$P(\text{no other node transmits in } [t_0-1, t_0]$

$$= p \cdot (1-p)^{N-1} \cdot (1-p)^{N-1}$$

$$= p \cdot (1-p)^{2(N-1)}$$

... choosing optimum  $p$  and then letting  $n$

$$= 1/(2e) = .18 \rightarrow \infty$$

even worse than slotted Aloha!