

Chapter 1

Introduction

A note on the use of these ppt slides:

We're making these slides freely available to all (faculty, students, readers). They're in PowerPoint form so you can add, modify, and delete slides (including this one) and slide content to suit your needs. They obviously represent a *lot* of work on our part. In return for use, we only ask the following:

- ❑ If you use these slides (e.g., in a class) in substantially unaltered form, that you mention their source (after all, we'd like people to use our book!)
- ❑ If you post any slides in substantially unaltered form on a www site, that you note that they are adapted from (or perhaps identical to) our slides, and note our copyright of this material.

Thanks and enjoy! JFK/KWR

All material copyright 1996-2007
J.F Kurose and K.W. Ross, All Rights Reserved

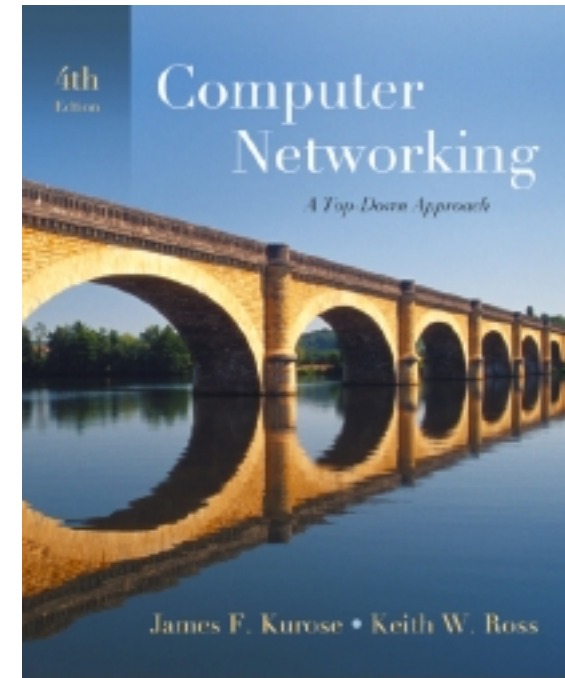

*Computer Networking:
A Top Down Approach ,
4th edition.*

Jim Kurose, Keith Ross
Addison-Wesley, July
2007.

Chapter 1: Introduction

Our goal:

- ❑ get “feel” and terminology
- ❑ more depth, detail *later* in course
- ❑ approach:
 - ❖ use Internet as example

Overview:

- ❑ what’s the Internet?
- ❑ what’s a protocol?
- ❑ network edge; hosts, access net, physical media
- ❑ network core: packet/circuit switching, Internet structure
- ❑ performance: loss, delay, throughput
- ❑ security
- ❑ protocol layers, service models
- ❑ history

Chapter 1: roadmap

1.1 What *is* the Internet?

1.2 Network edge

- end systems, access networks, links

1.3 Network core

- circuit switching, packet switching, network structure

1.4 Delay, loss and throughput in packet-switched networks

1.5 Protocol layers, service models

1.6 Networks under attack: security

1.7 History

What's the Internet: "nuts and bolts" view



PC



server



wireless laptop



cellular handheld



access points

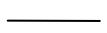

wired links



router

- millions of connected computing devices:
hosts = end systems

- ❖ running *network apps*

- *communication links*

- ❖ fiber, copper, radio, satellite

- ❖ transmission rate = *bandwidth*

- *routers*: forward packets (chunks of data)

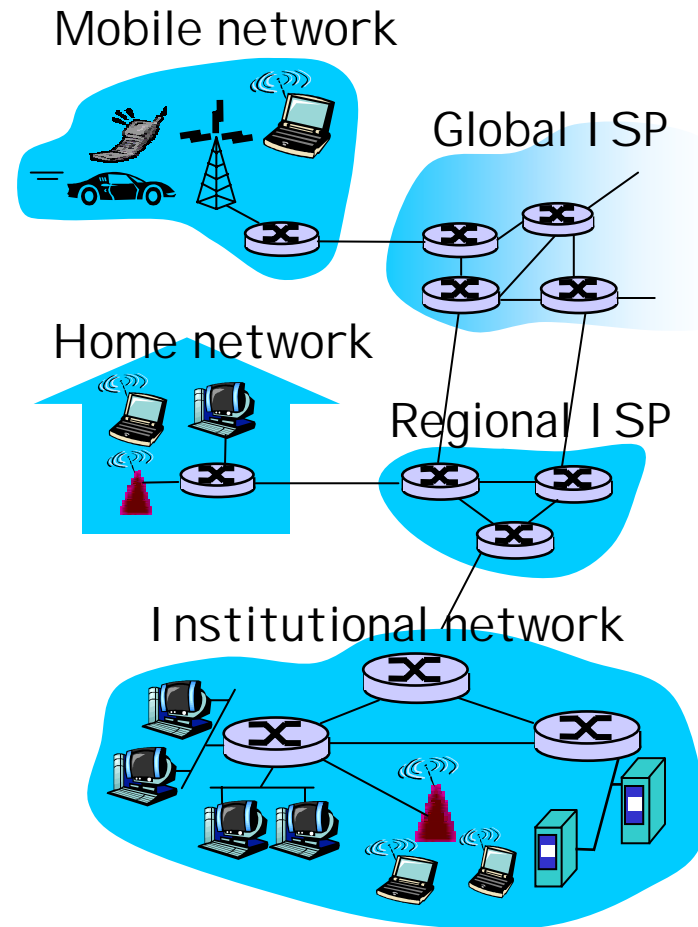

“Cool” internet appliances



IP picture frame
<http://www.ceiva.com/>



Web-enabled toaster +
weather forecaster



World's smallest web server
<http://www-ccs.cs.umass.edu/~shri/iPic.html>



Internet phones

What's the Internet: "nuts and bolts" view

- ❑ *protocols* control sending, receiving of msgs
 - ❖ e.g., TCP, IP, HTTP, Skype, Ethernet
- ❑ *Internet: "network of networks"*
 - ❖ loosely hierarchical
 - ❖ public Internet versus private intranet
- ❑ Internet standards
 - ❖ RFC: Request for comments
 - ❖ IETF: Internet Engineering Task Force

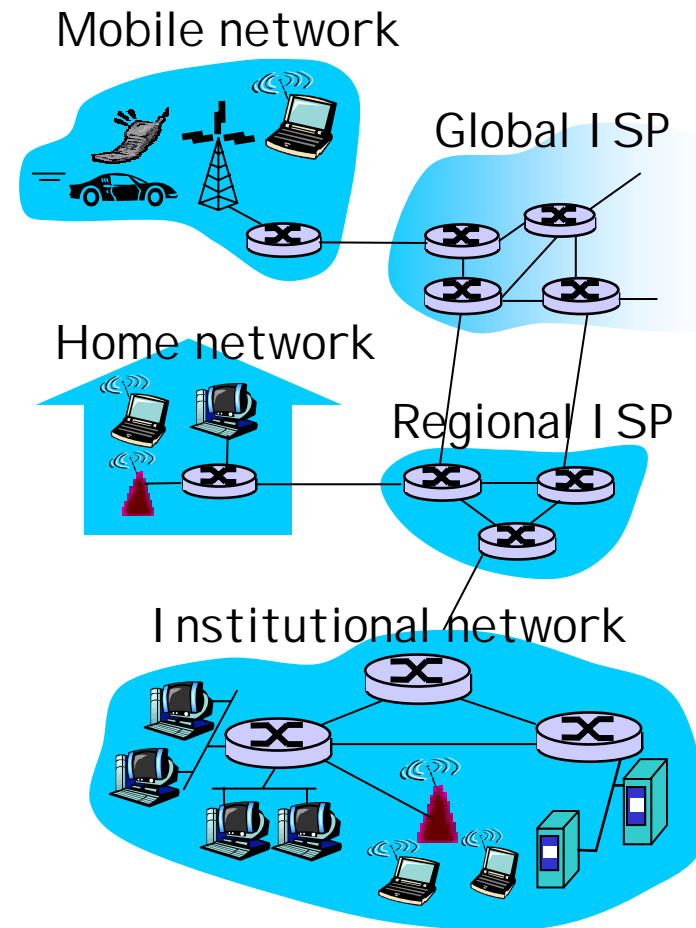

What's the Internet: a service view

- **communication infrastructure** enables distributed applications:
 - ❖ Web, VoIP, email, games, e-commerce, file sharing
- **communication services provided to apps:**
 - ❖ reliable data delivery from source to destination
 - ❖ "best effort" (unreliable) data delivery

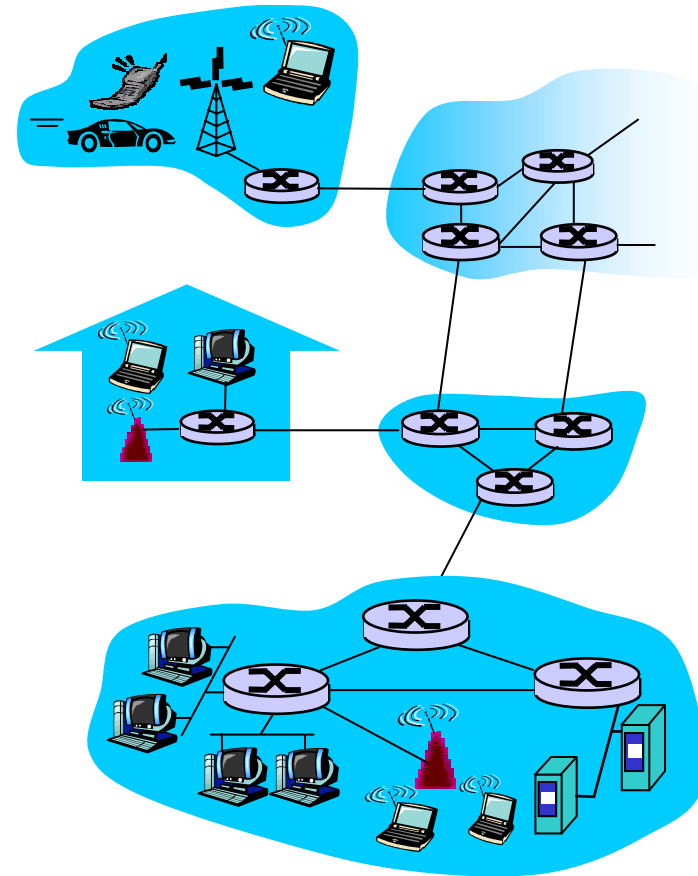

What's a protocol?

human protocols:

- ❑ "what's the time?"
- ❑ "I have a question"
- ❑ introductions

... specific msgs sent

... specific actions taken
when msgs received,
or other events

network protocols:

- ❑ machines rather than humans
- ❑ all communication activity in Internet governed by protocols

*protocols define format,
order of msgs sent and
received among network
entities, and actions
taken on msg
transmission, receipt*

What's a protocol?

a human protocol and a computer network protocol:

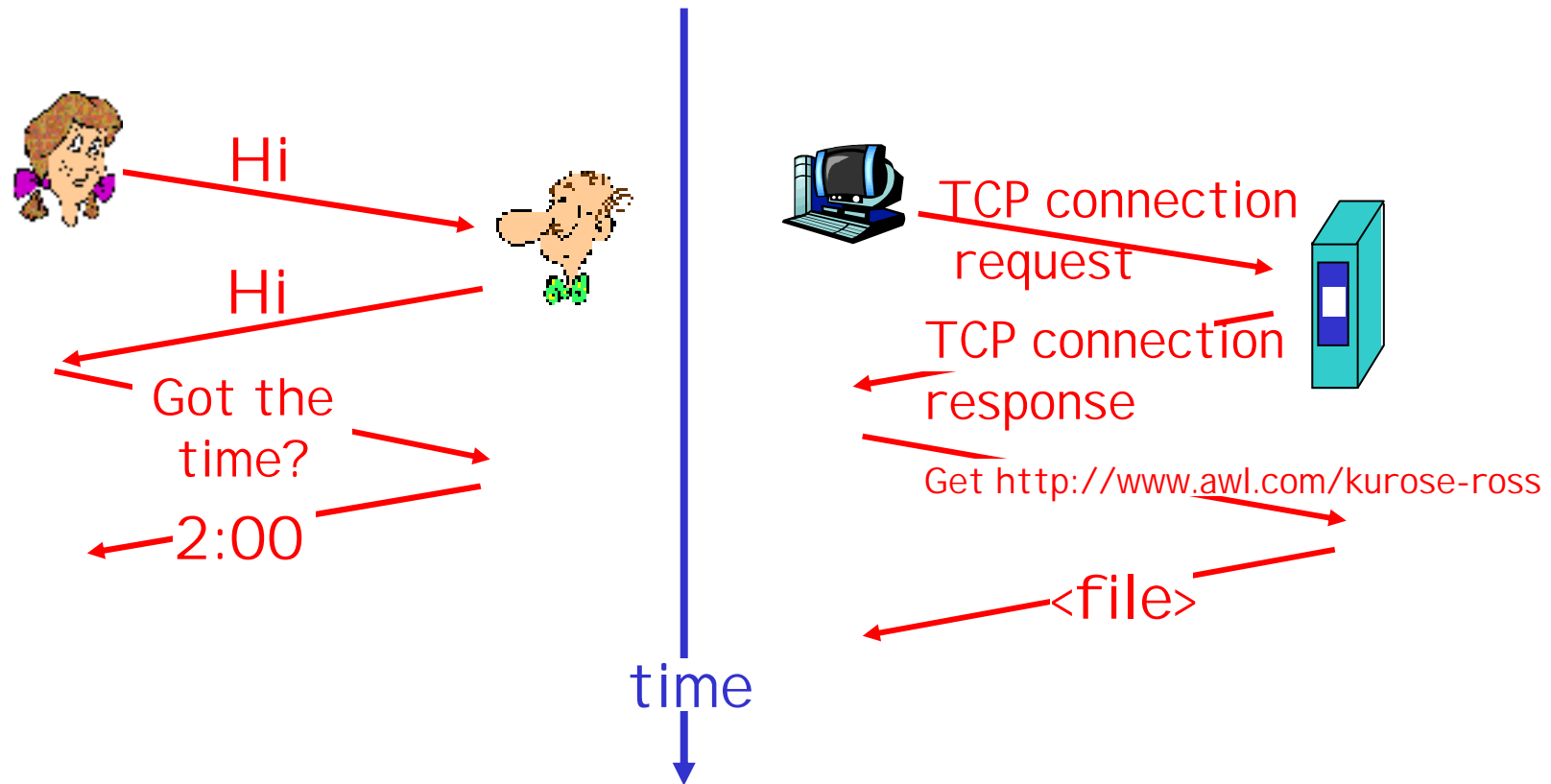

Q: Other human protocols?

Chapter 1: roadmap

1.1 What *is* the Internet?

1.2 Network edge

- end systems, access networks, links

1.3 Network core

- circuit switching, packet switching, network structure

1.4 Delay, loss and throughput in packet-switched networks

1.5 Protocol layers, service models

1.6 Networks under attack: security

1.7 History

A closer look at network structure:

- **network edge:**
applications and hosts
- **access networks, physical media:**
wired, wireless communication links
- **network core:**
 - ❖ interconnected routers
 - ❖ network of networks

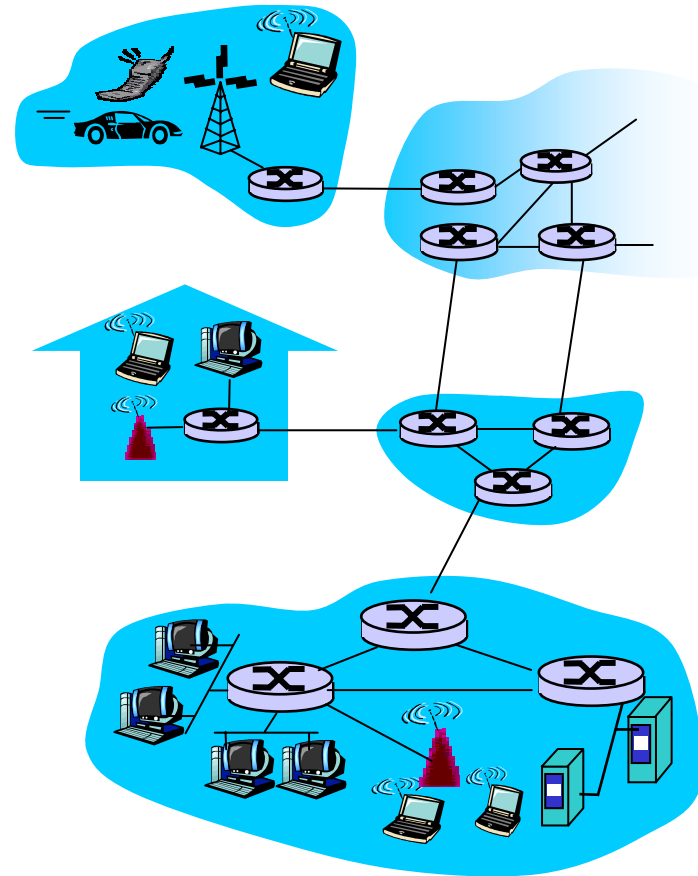

The network edge:

□ end systems (hosts):

- ❖ run application programs
- ❖ e.g. Web, email
- ❖ at “edge of network”

□ client/server model

- ❖ client host requests, receives service from always-on server
- ❖ e.g. Web browser/server; email client/server

□ peer-peer model:

- ❖ minimal (or no) use of dedicated servers
- ❖ e.g. Skype, BitTorrent

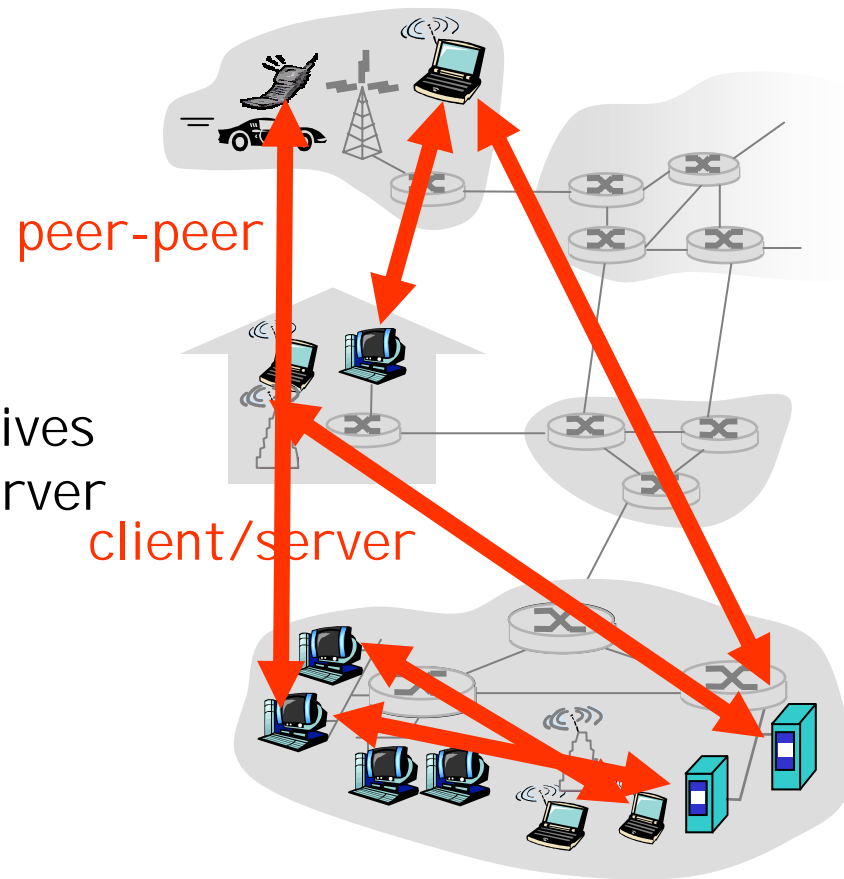

Access networks and physical media

Q: How to connect end systems to edge router?

- ❑ residential access nets
- ❑ institutional access networks (school, company)
- ❑ mobile access networks

Keep in mind:

- ❑ bandwidth (bits per second) of access network?
- ❑ shared or dedicated?

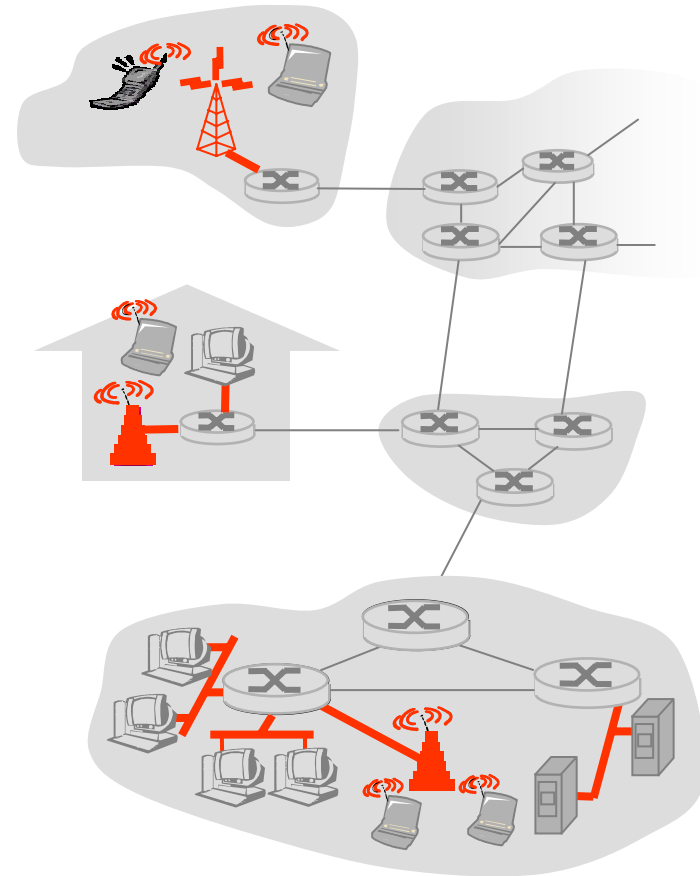

Residential access: point to point access

❑ Dialup via modem

- ❖ up to 56Kbps direct access to router (often less)
- ❖ Can't surf and phone at same time: can't be "always on"

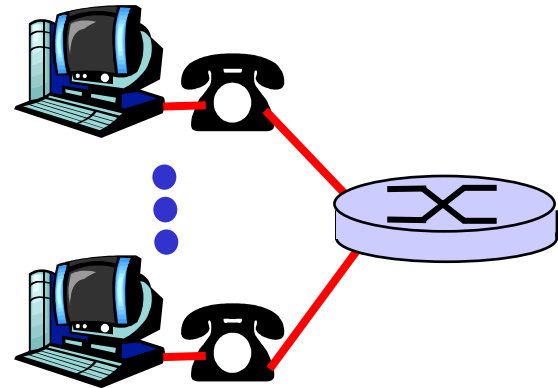

❑ DSL: digital subscriber line

- ❖ deployment: telephone company (typically)
- ❖ up to 1 Mbps upstream (today typically < 256 kbps)
- ❖ up to 8 Mbps downstream (today typically < 1 Mbps)
- ❖ dedicated physical line to telephone central office

Residential access: cable modems

- ❑ HFC: hybrid fiber coax
 - ❖ asymmetric: up to 30Mbps downstream, 2 Mbps upstream
- ❑ network of cable and fiber attaches homes to ISP router
 - ❖ homes share access to router
- ❑ deployment: available via cable TV companies

Residential access: cable modems

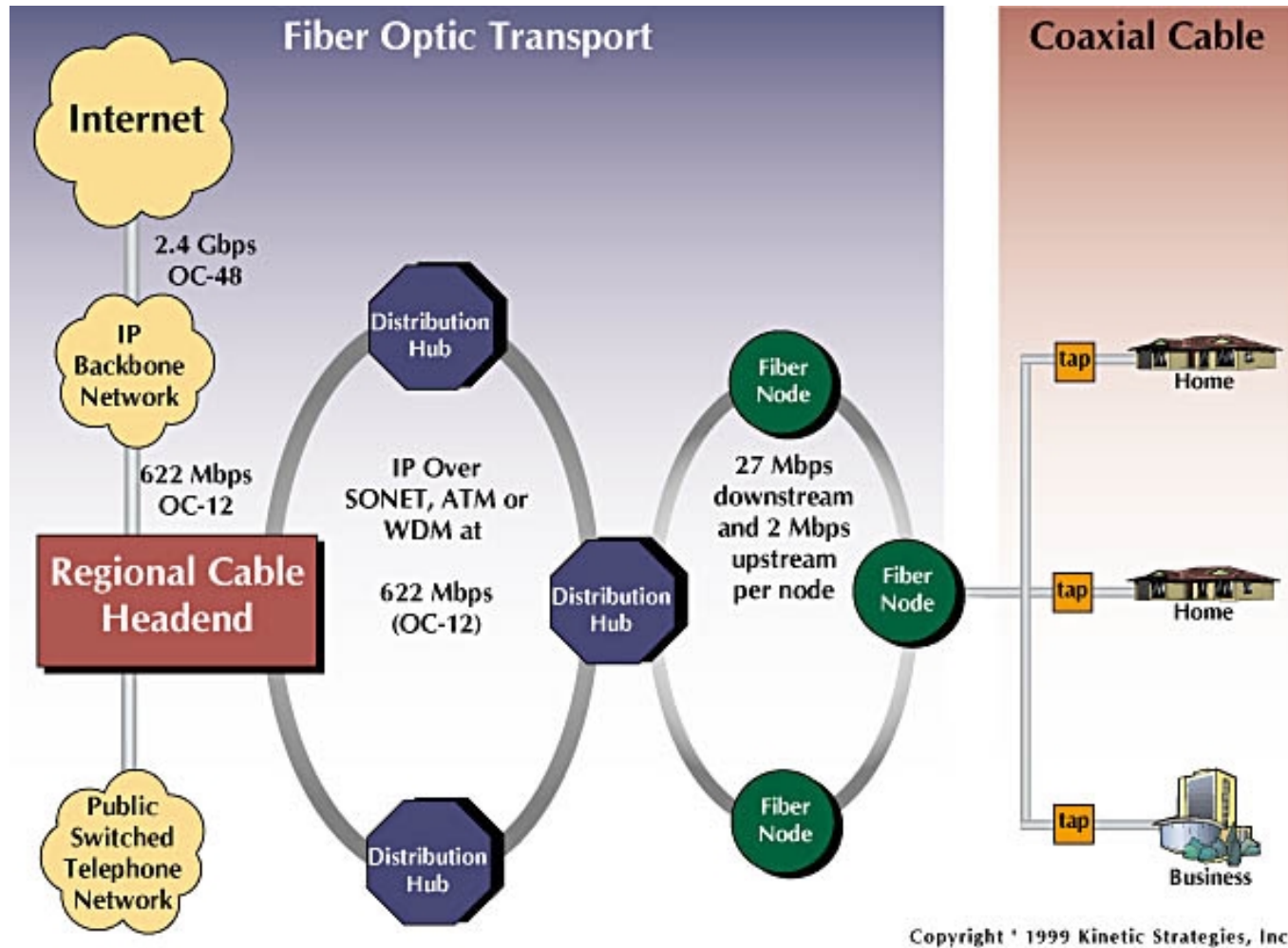

Cable Network Architecture: Overview

Typically 500 to 5,000 homes

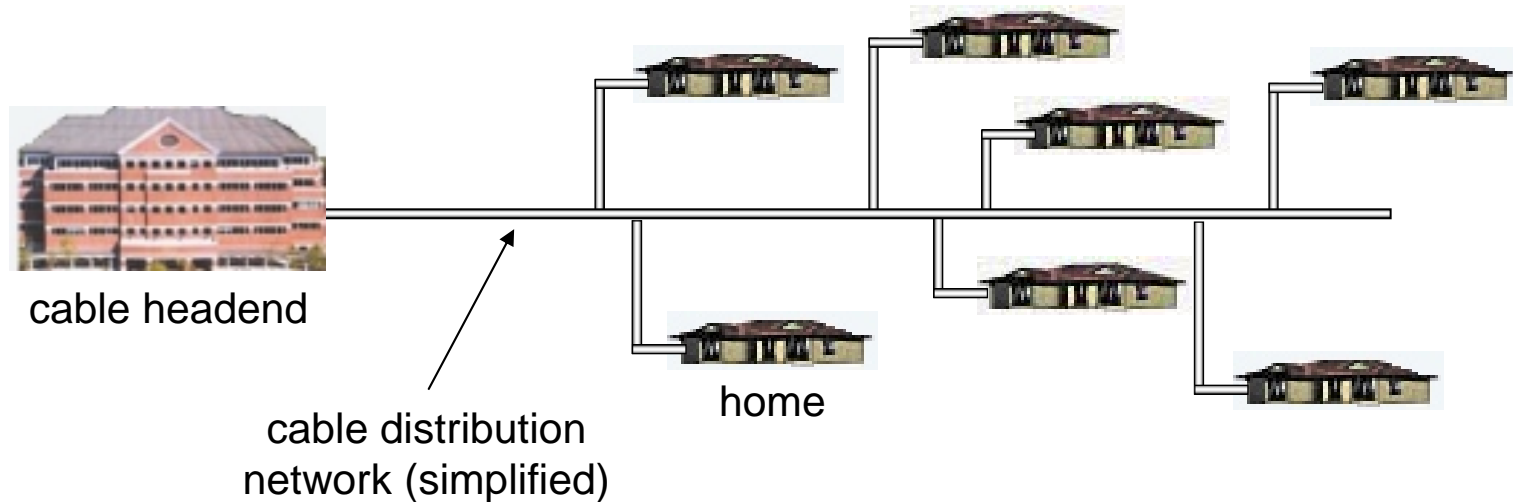

Cable Network Architecture: Overview

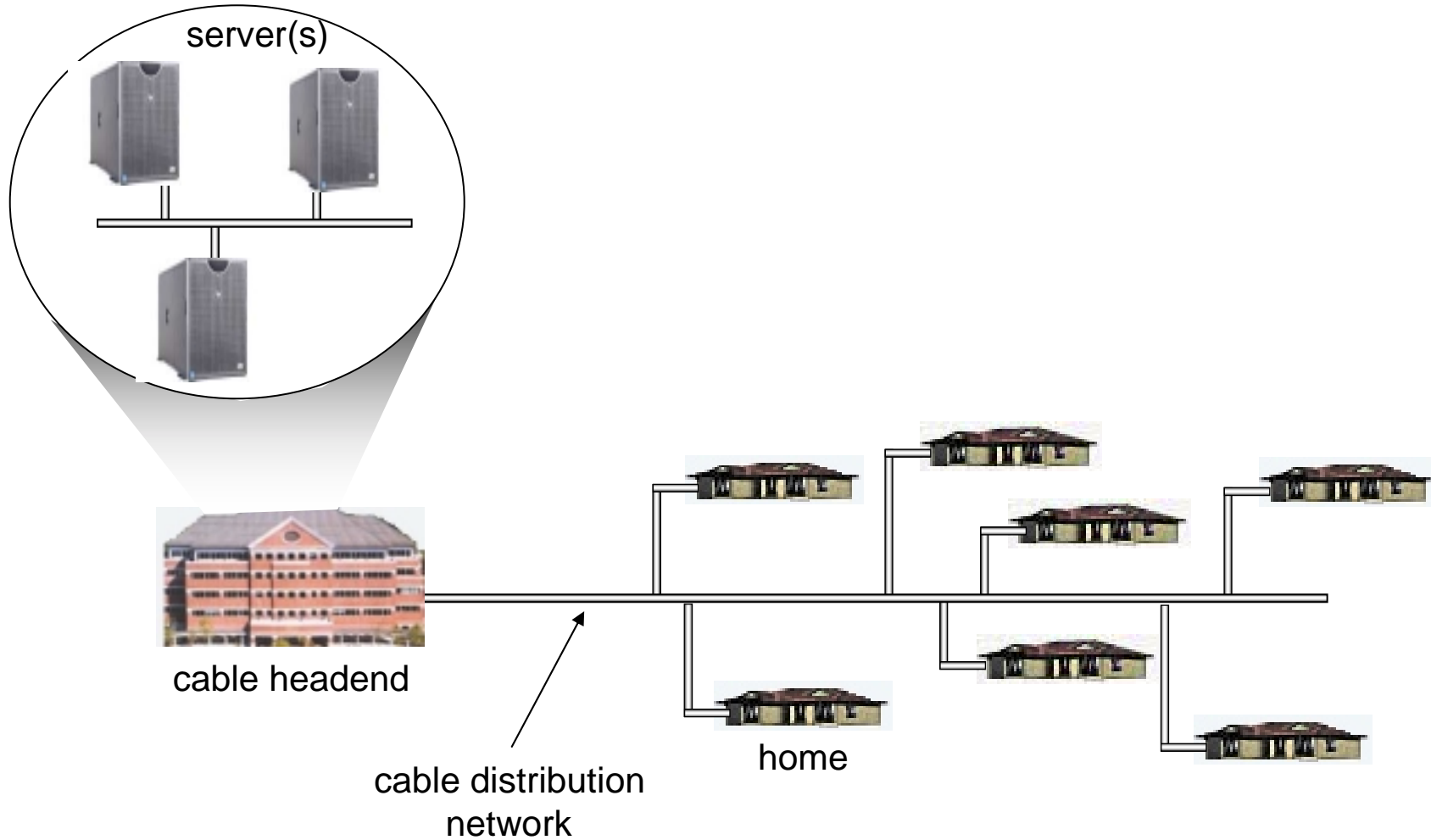

Cable Network Architecture: Overview

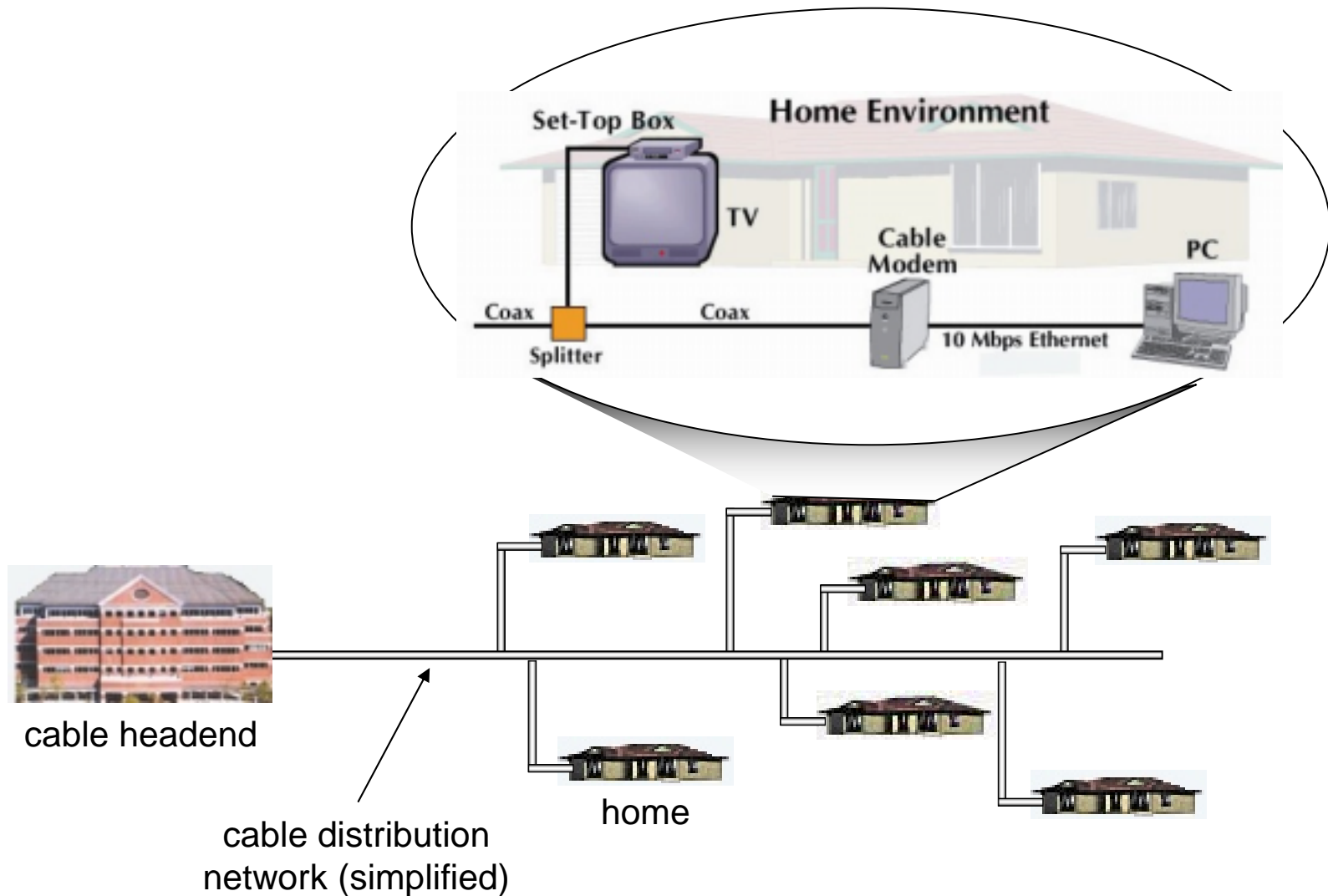

Cable Network Architecture: Overview

FDM (more shortly):

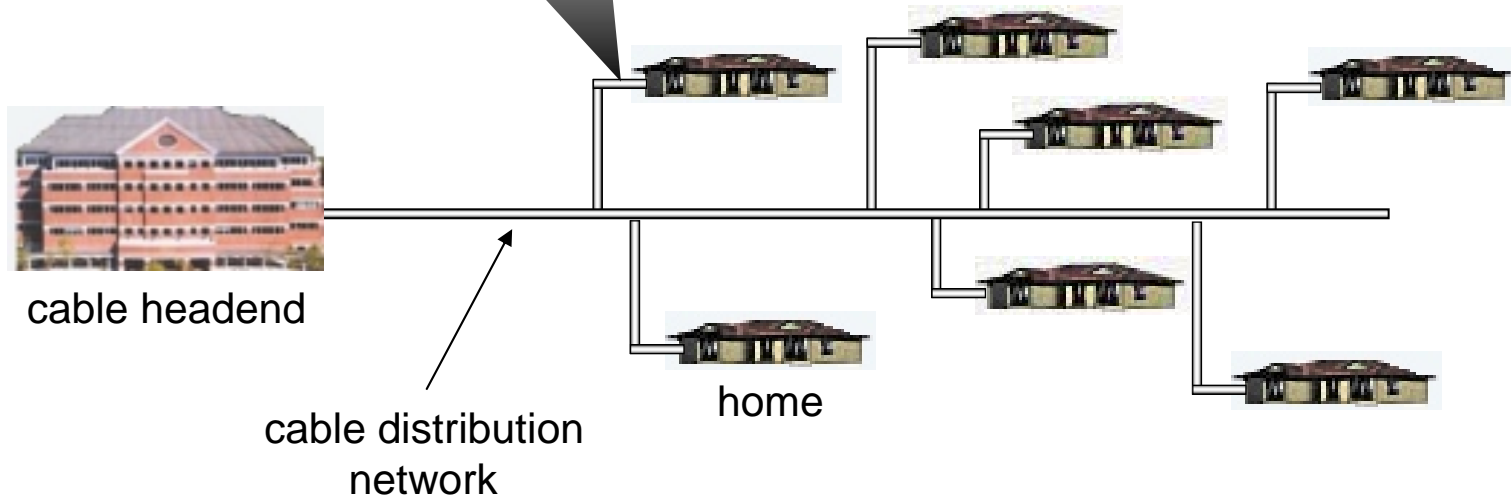
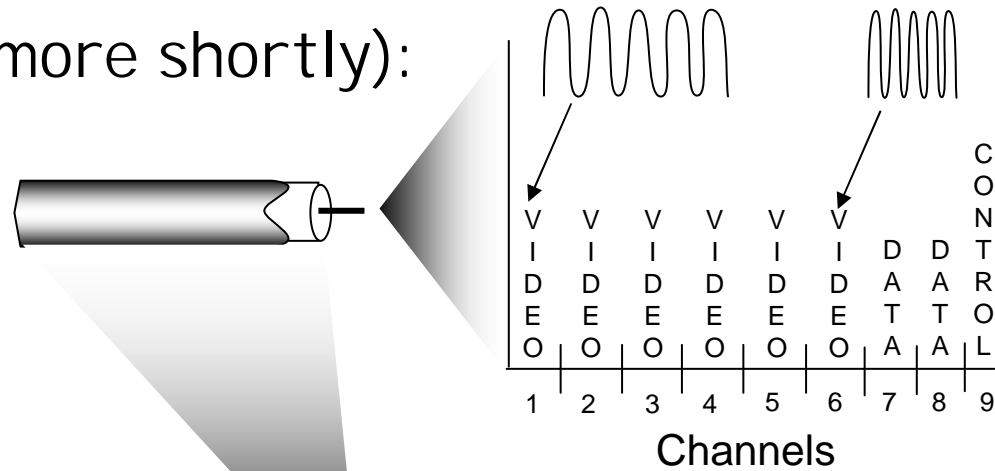

Company access: local area networks

- ❑ company/univ **local area network** (LAN) connects end system to edge router
- ❑ **Ethernet:**
 - ❖ 10 Mbs, 100Mbps, 1Gbps, 10Gbps Ethernet
 - ❖ modern configuration: end systems connect into *Ethernet switch*
- ❑ LANs: chapter 5

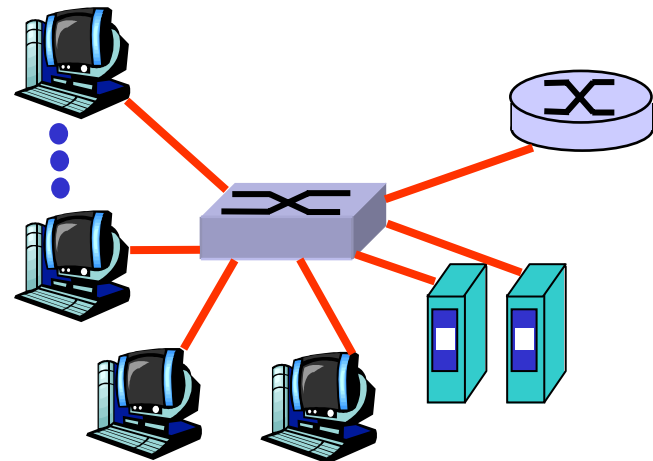
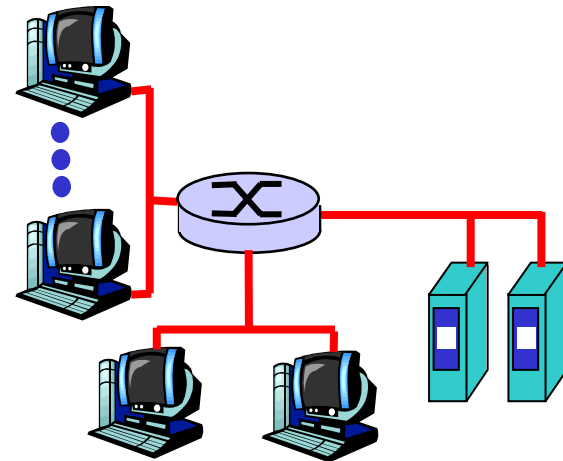

Wireless access networks

- ❑ shared *wireless* access network connects end system to router
 - ❖ via base station aka "access point"
- ❑ **wireless LANs:**
 - ❖ 802.11b/g (WiFi): 11 or 54 Mbps
- ❑ **wider-area wireless access**
 - ❖ provided by telco operator
 - ❖ ~1Mbps over cellular system (EVDO, HSDPA)
 - ❖ next up (?): WiMAX (10's Mbps) over wide area

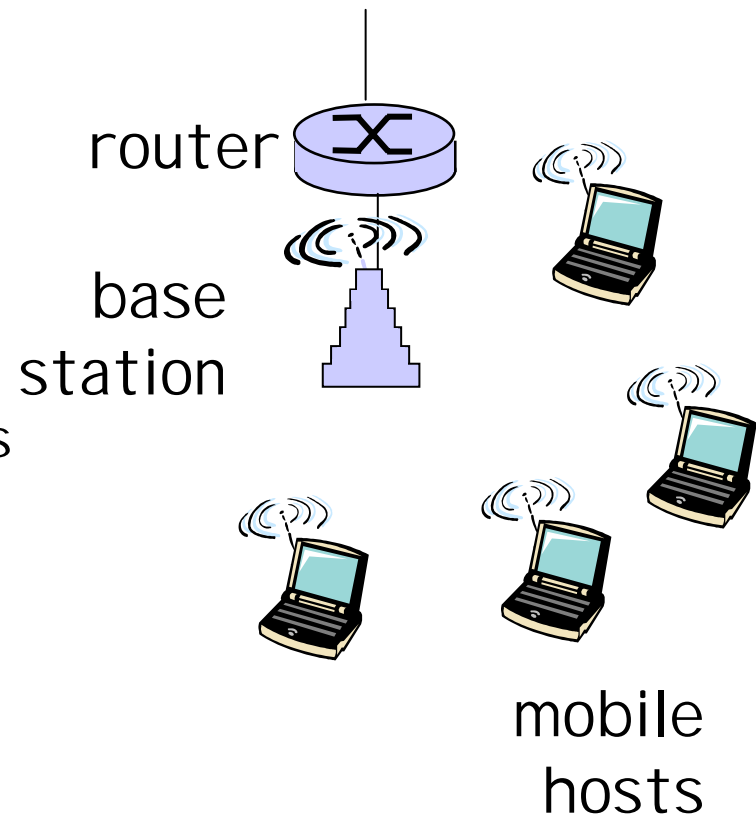

Home networks

Typical home network components:

- ❑ DSL or cable modem
- ❑ router/firewall/NAT
- ❑ Ethernet
- ❑ wireless access point

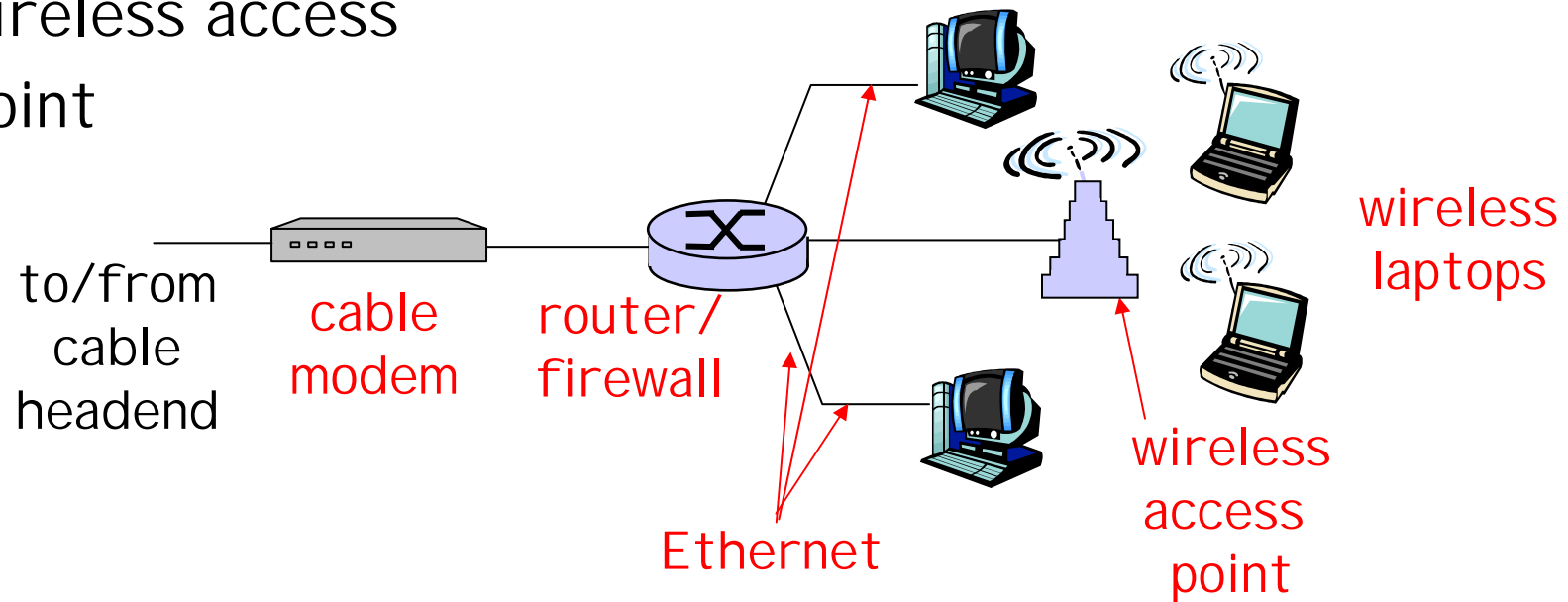

Physical Media

- ❑ **Bit:** propagates between transmitter/rcvr pairs
- ❑ **physical link:** what lies between transmitter & receiver
- ❑ **guided media:**
 - ❖ signals propagate in solid media: copper, fiber, coax
- ❑ **unguided media:**
 - ❖ signals propagate freely, e.g., radio

Twisted Pair (TP)

- ❑ two insulated copper wires
 - ❖ Category 3: traditional phone wires, 10 Mbps Ethernet
 - ❖ Category 5: 100Mbps Ethernet



Physical Media: coax, fiber

Coaxial cable:

- ❑ two concentric copper conductors
- ❑ bidirectional
- ❑ baseband:
 - ❖ single channel on cable
 - ❖ legacy Ethernet
- ❑ broadband:
 - ❖ multiple channels on cable
 - ❖ HFC

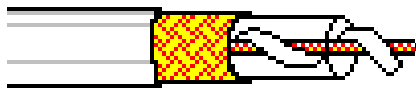

Fiber optic cable:

- ❑ glass fiber carrying light pulses, each pulse a bit
- ❑ high-speed operation:
 - ❖ high-speed point-to-point transmission (e.g., 10's-100's Gps)
- ❑ low error rate: repeaters spaced far apart ; immune to electromagnetic noise



Physical media: radio

- ❑ signal carried in electromagnetic spectrum
- ❑ no physical “wire”
- ❑ bidirectional
- ❑ propagation environment effects:
 - ❖ reflection
 - ❖ obstruction by objects
 - ❖ interference

Radio link types:

- ❑ **terrestrial microwave**
 - ❖ e.g. up to 45 Mbps channels
- ❑ **LAN** (e.g., Wifi)
 - ❖ 11Mbps, 54 Mbps
- ❑ **wide-area** (e.g., cellular)
 - ❖ 3G cellular: ~ 1 Mbps
- ❑ **satellite**
 - ❖ Kbps to 45Mbps channel (or multiple smaller channels)
 - ❖ 270 msec end-end delay
 - ❖ geosynchronous versus low altitude

Chapter 1: roadmap

1.1 What *is* the Internet?

1.2 Network edge

- end systems, access networks, links

1.3 Network core

- circuit switching, packet switching, network structure

1.4 Delay, loss and throughput in packet-switched networks

1.5 Protocol layers, service models

1.6 Networks under attack: security

1.7 History

The Network Core

- ❑ mesh of interconnected routers
- ❑ the fundamental question: how is data transferred through net?
 - ❖ circuit switching: dedicated circuit per call: telephone net
 - ❖ packet-switching: data sent thru net in discrete "chunks"

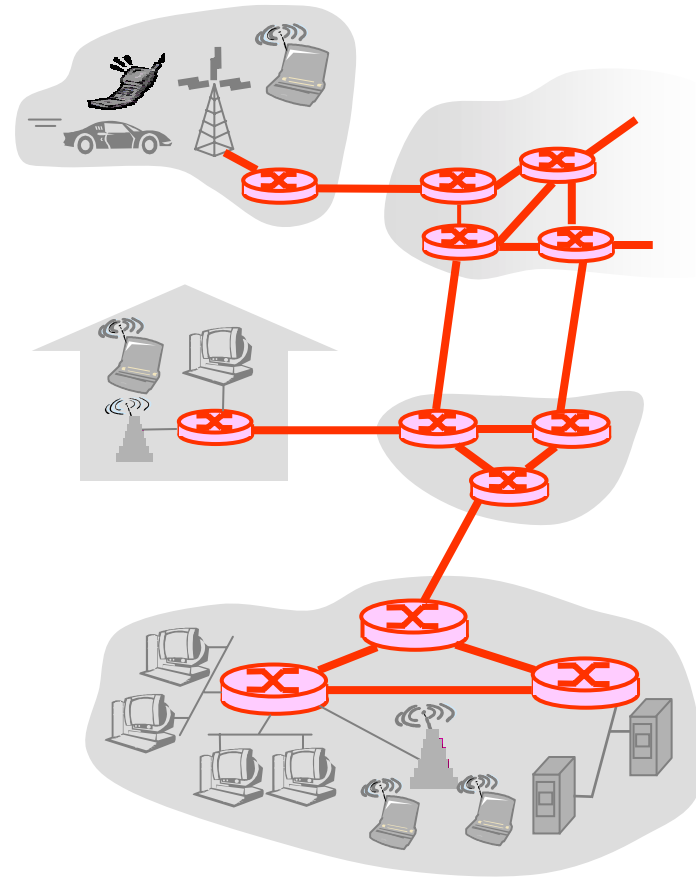

Network Core: Circuit Switching

End-end resources reserved for "call"

- ❑ link bandwidth, switch capacity
- ❑ dedicated resources: no sharing
- ❑ circuit-like (guaranteed) performance
- ❑ call setup required

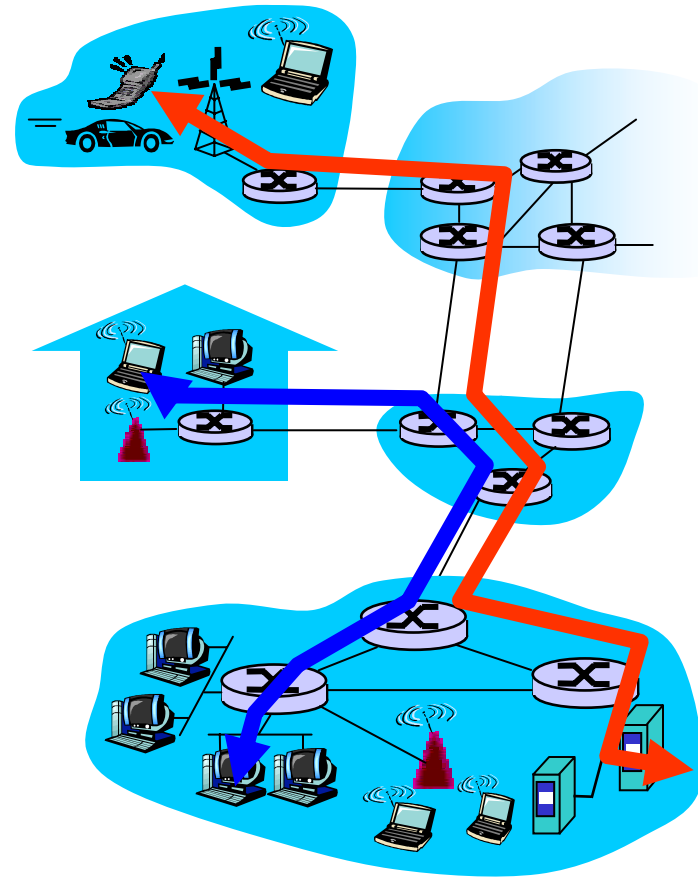

Network Core: Circuit Switching

network resources
(e.g., bandwidth)

divided into "pieces"

- pieces allocated to calls
- resource piece *idle* if not used by owning call
(*no sharing*)

- dividing link bandwidth into "pieces"
 - ❖ frequency division
 - ❖ time division

Circuit Switching: FDM and TDM

FDM

Example:

4 users

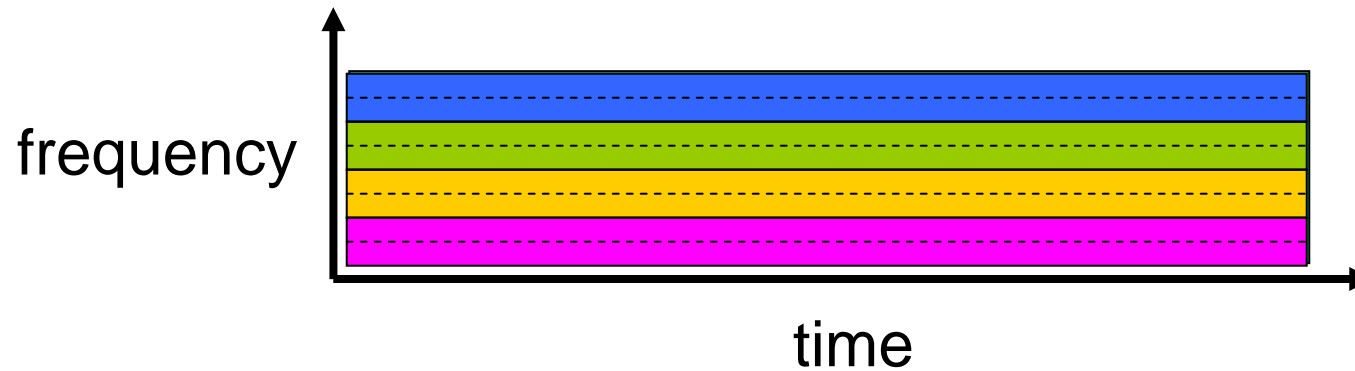

TDM

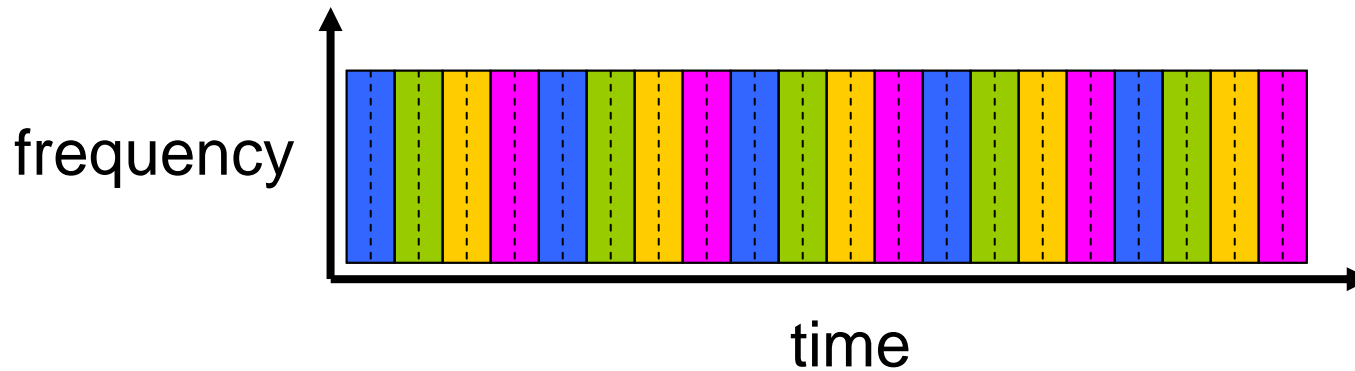

Numerical example

- How long does it take to send a file of 640,000 bits from host A to host B over a circuit-switched network?
 - ❖ All links are 1.536 Mbps
 - ❖ Each link uses TDM with 24 slots/sec
 - ❖ 500 msec to establish end-to-end circuit

Let's work it out!

Network Core: Packet Switching

each end-end data stream
divided into *packets*

- ❑ user A, B packets *share* network resources
- ❑ each packet uses full link bandwidth
- ❑ resources used *as needed*

Bandwidth division into "pieces"
Dedicated allocation
Resource reservation

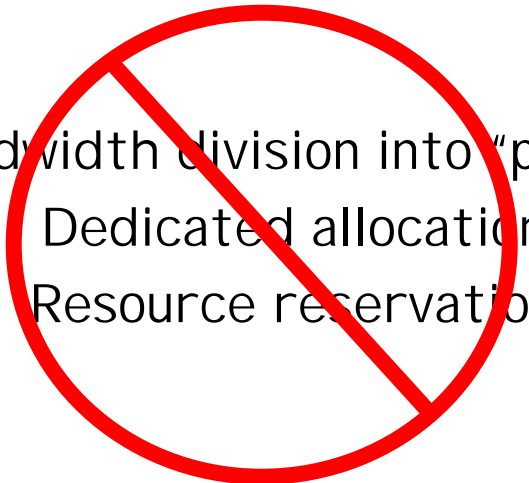

resource contention:

- ❑ aggregate resource demand can exceed amount available
- ❑ congestion: packets queue, wait for link use
- ❑ store and forward: packets move one hop at a time
 - ❖ Node receives complete packet before forwarding

Packet Switching: Statistical Multiplexing

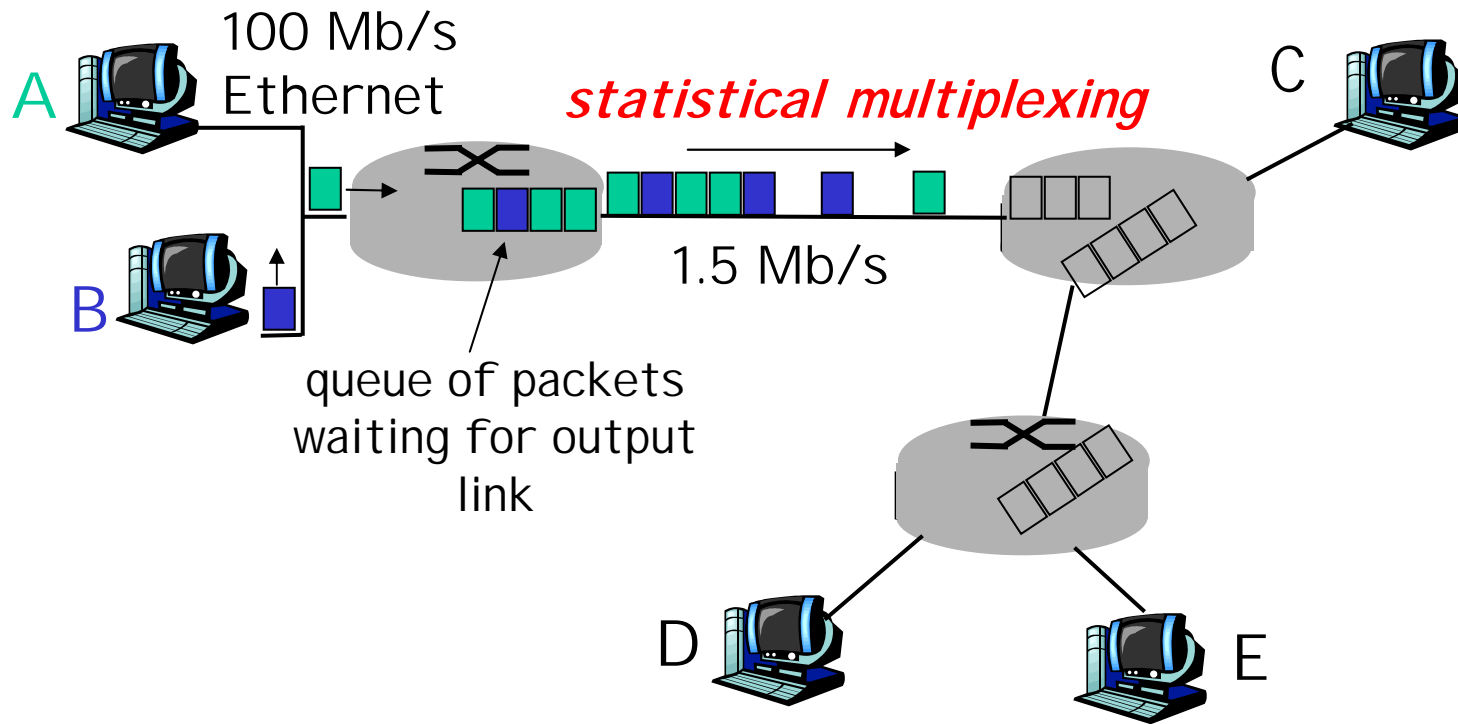

Sequence of A & B packets does not have fixed pattern,
bandwidth shared on demand → *statistical multiplexing*.
TDM: each host gets same slot in revolving TDM frame.

Packet-switching: store-and-forward

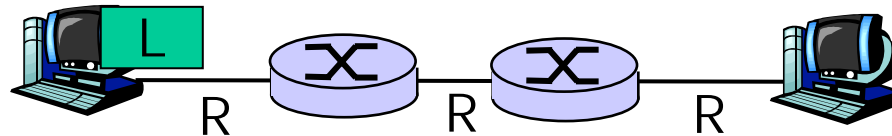

- takes L/R seconds to transmit (push out) packet of L bits on to link at R bps
- *store and forward*: entire packet must arrive at router before it can be transmitted on next link
- delay = $3L/R$ (assuming zero propagation delay)

Example:

- $L = 7.5$ Mbits
- $R = 1.5$ Mbps
- transmission delay = 15 sec

} more on delay shortly ...

Packet switching versus circuit switching

Packet switching allows more users to use network!

- ❑ 1 Mb/s link
- ❑ each user:
 - ❖ 100 kb/s when “active”
 - ❖ active 10% of time

- ❑ *circuit-switching:*

- ❖ 10 users

- ❑ *packet switching:*

- ❖ with 35 users, probability > 10 active at same time is less than .0004

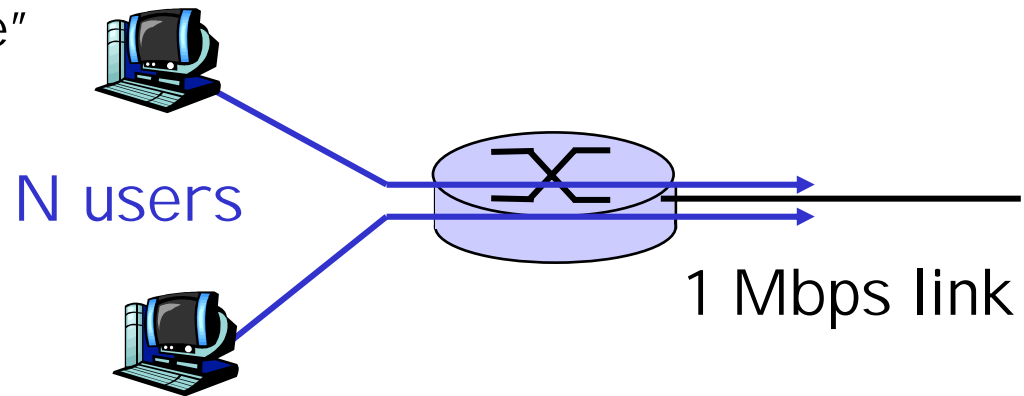

Q: how did we get value 0.0004?

Packet switching versus circuit switching

Is packet switching a “slam dunk winner?”

- great for bursty data
 - ❖ resource sharing
 - ❖ simpler, no call setup
- **excessive congestion:** packet delay and loss
 - ❖ protocols needed for reliable data transfer, congestion control
- **Q: How to provide circuit-like behavior?**
 - ❖ bandwidth guarantees needed for audio/video apps
 - ❖ still an unsolved problem (chapter 7)

Q: human analogies of reserved resources (circuit switching) versus on-demand allocation (packet-switching)?

Internet structure: network of networks

- roughly hierarchical
- **at center: "tier-1" ISPs** (e.g., Verizon, Sprint, AT&T, Cable and Wireless), national/international coverage
 - ❖ treat each other as equals

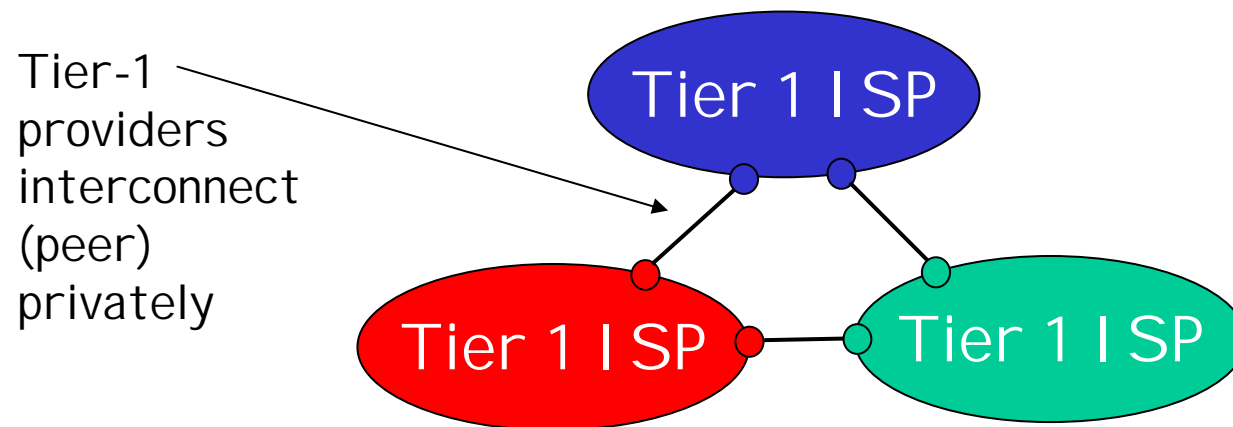

Tier-1 ISP: e.g., Sprint

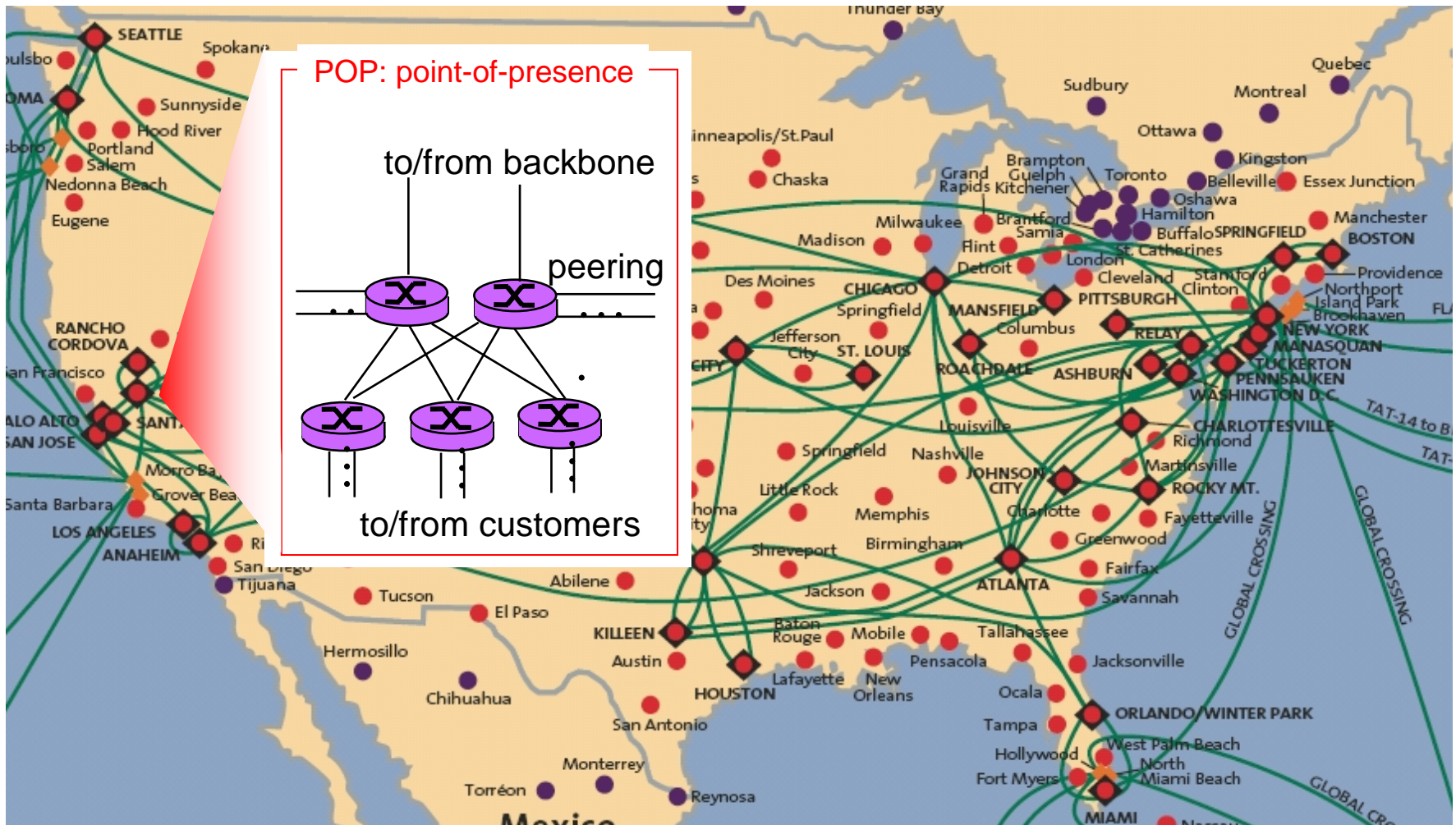

Internet structure: network of networks

□ "Tier-2" ISPs: smaller (often regional) ISPs

- ❖ Connect to one or more tier-1 ISPs, possibly other tier-2 ISPs

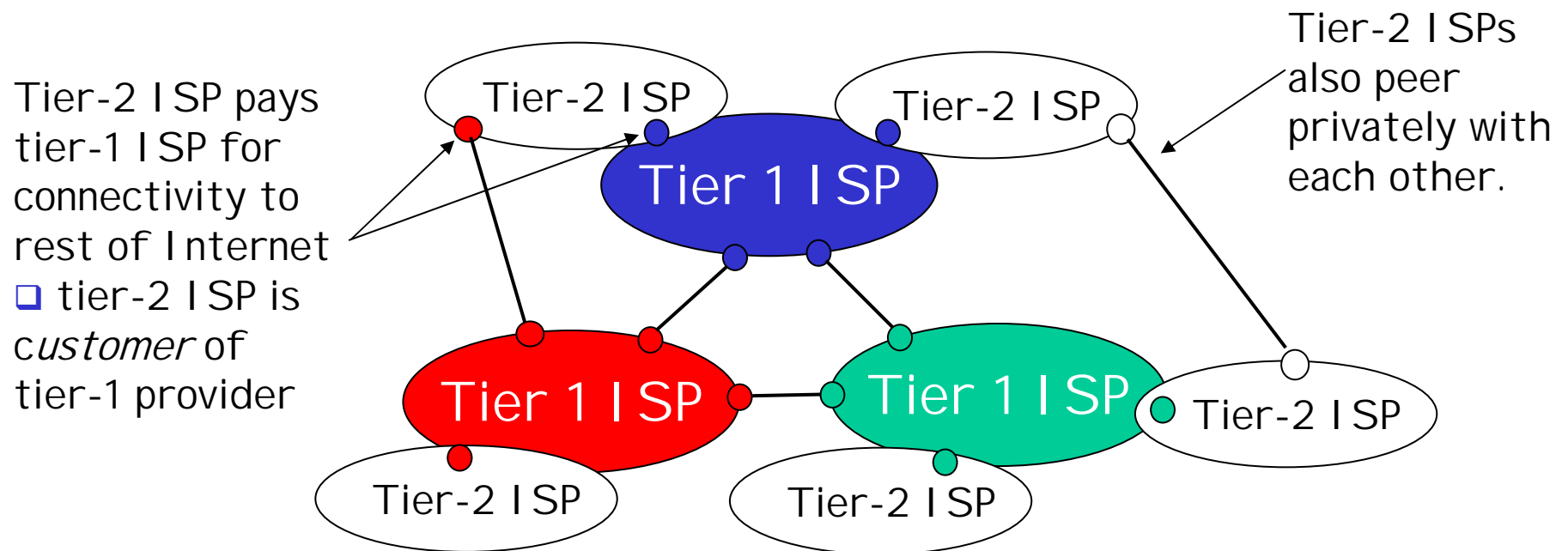

Internet structure: network of networks

□ "Tier-3" ISPs and local ISPs

- ❖ last hop ("access") network (closest to end systems)

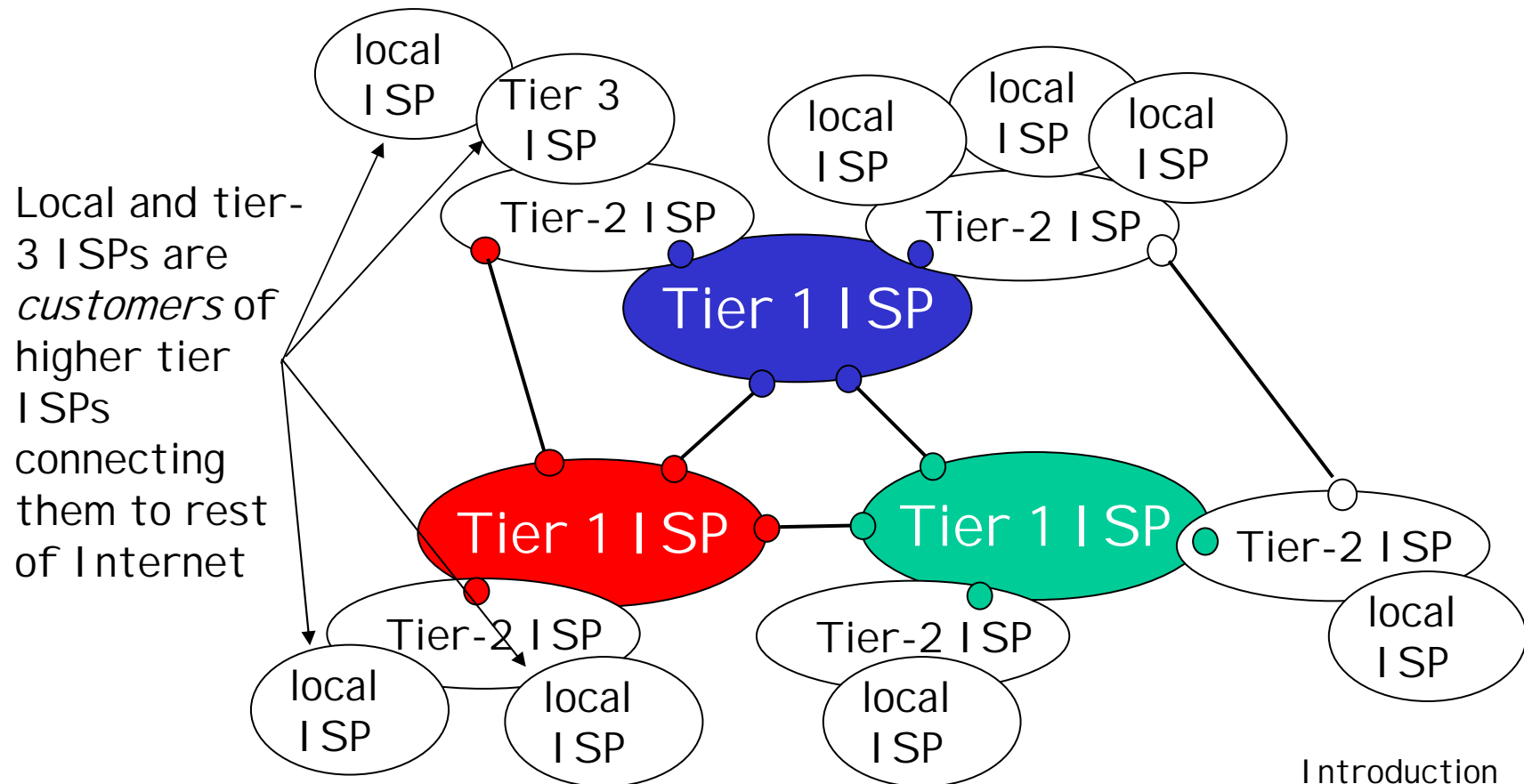

Internet structure: network of networks

- a packet passes through many networks!

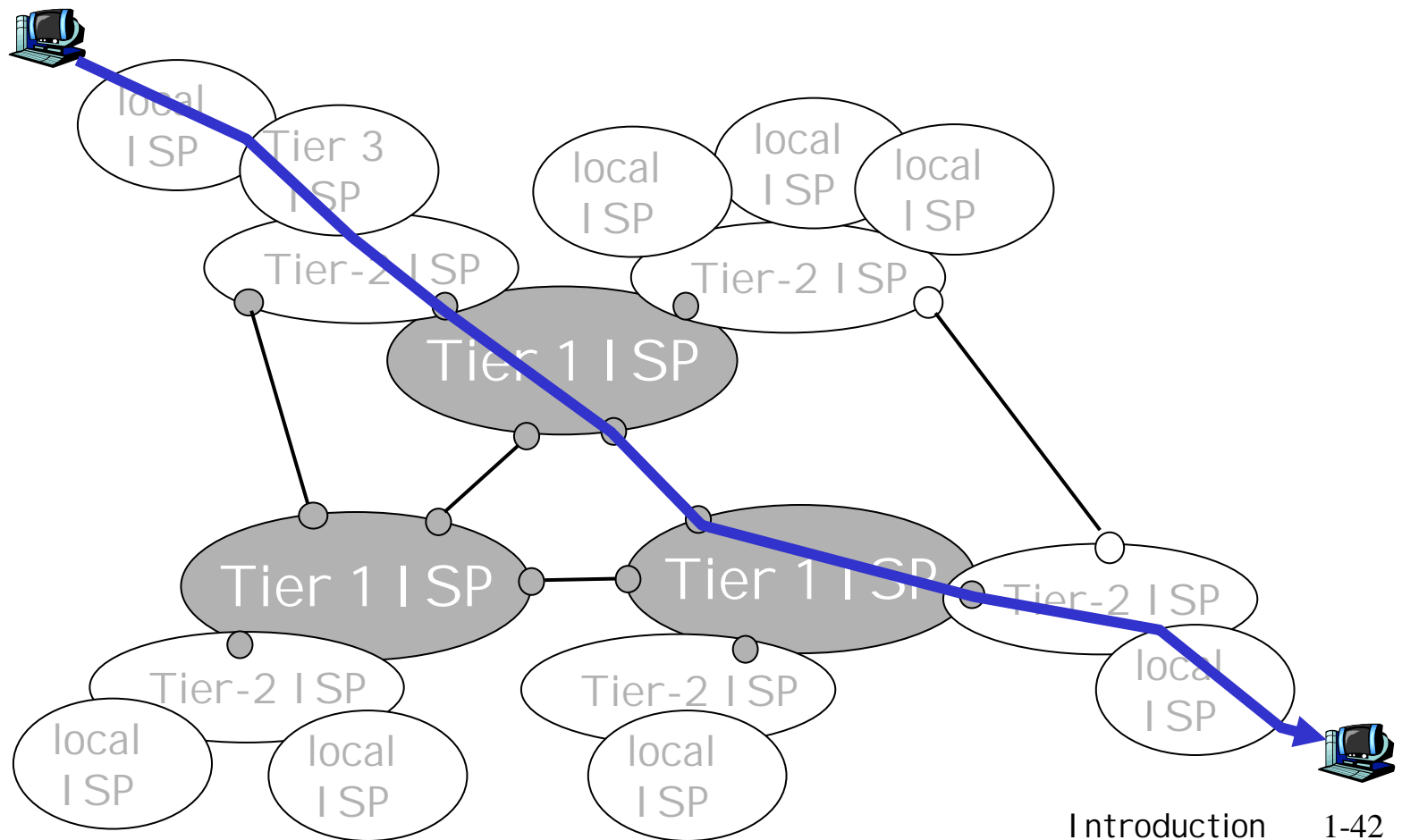

Chapter 1: roadmap

1.1 What *is* the Internet?

1.2 Network edge

- end systems, access networks, links

1.3 Network core

- circuit switching, packet switching, network structure

1.4 Delay, loss and throughput in packet-switched networks

1.5 Protocol layers, service models

1.6 Networks under attack: security

1.7 History

How do loss and delay occur?

packets *queue* in router buffers

- ❑ packet arrival rate to link exceeds output link capacity
- ❑ packets queue, wait for turn

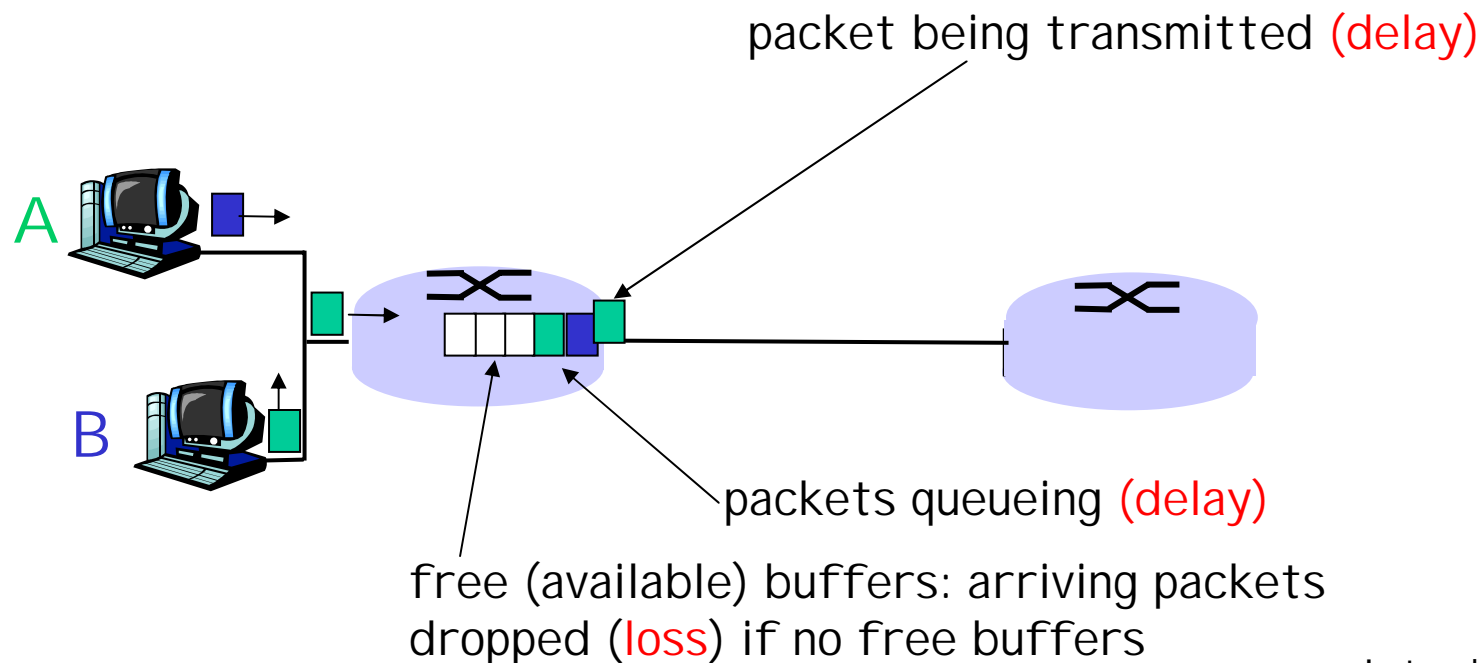

Four sources of packet delay

❑ 1. nodal processing:

- ❖ check bit errors
- ❖ determine output link

❑ 2. queueing

- ❖ time waiting at output link for transmission
- ❖ depends on congestion level of router

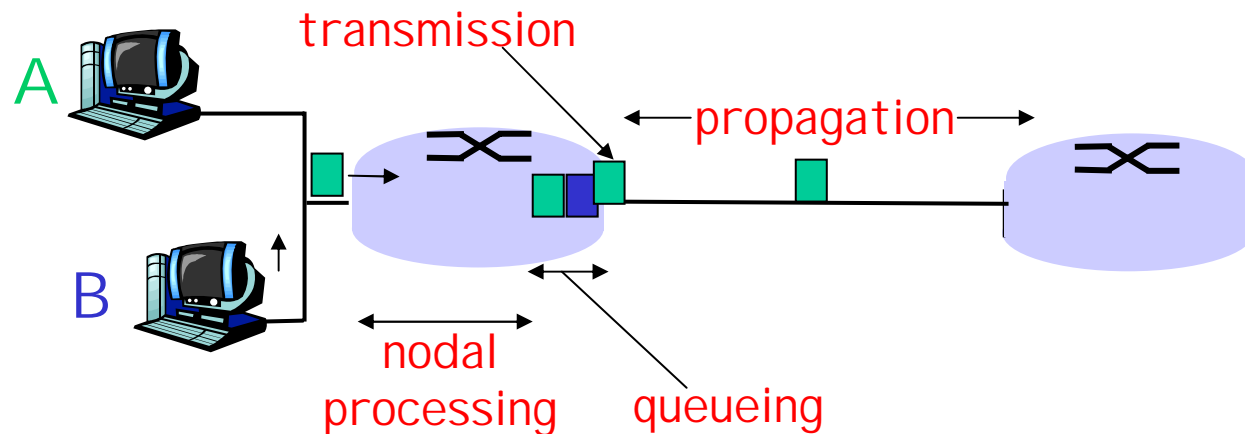

Delay in packet-switched networks

3. Transmission delay:

- R = link bandwidth (bps)
- L = packet length (bits)
- time to send bits into link = L/R

4. Propagation delay:

- d = length of physical link
- s = propagation speed in medium ($\sim 2 \times 10^8$ m/sec)
- propagation delay = d/s

Note: s and R are *very* different quantities!

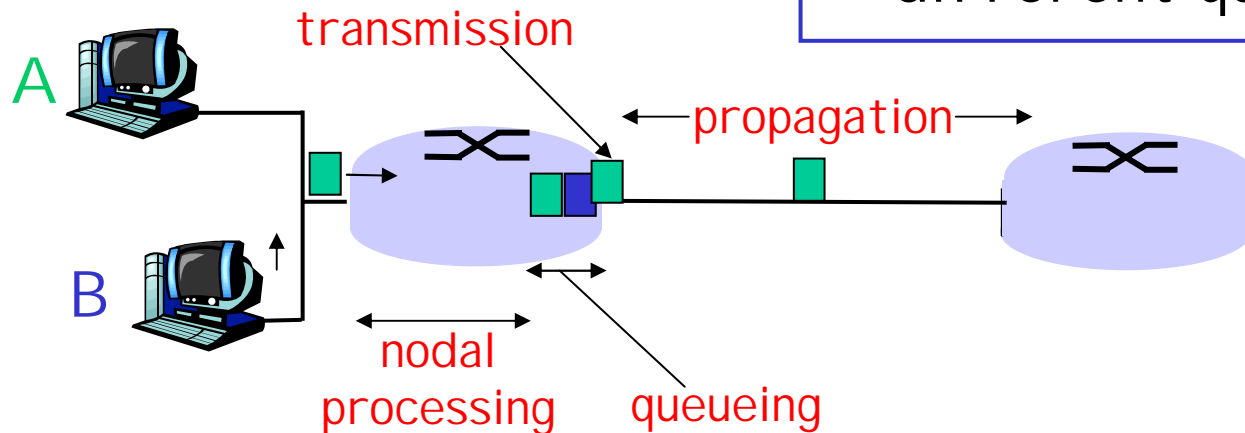

Caravan analogy

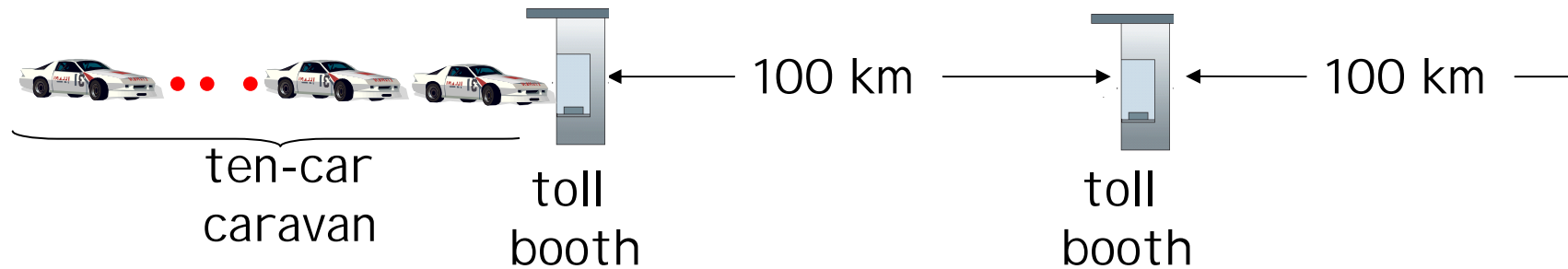

- ❑ cars “propagate” at 100 km/hr
- ❑ toll booth takes 12 sec to service car (transmission time)
- ❑ car ~ bit; caravan ~ packet
- ❑ **Q: How long until caravan is lined up before 2nd toll booth?**
- ❑ Time to “push” entire caravan through toll booth onto highway = $12 * 10 = 120$ sec
- ❑ Time for last car to propagate from 1st to 2nd toll booth: $100 \text{ km} / (100 \text{ km/hr}) = 1$ hr
- ❑ **A: 62 minutes**

Caravan analogy (more)

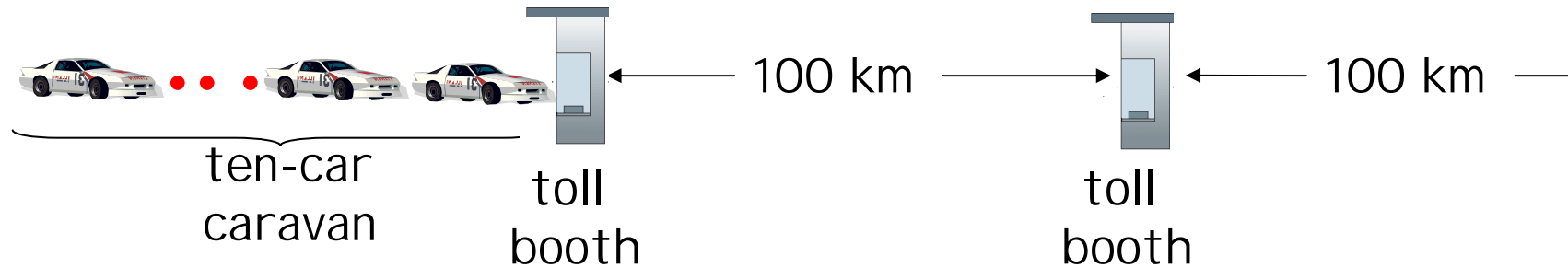

- ❑ Cars now “propagate” at 1000 km/hr
- ❑ Toll booth now takes 1 min to service a car
- ❑ **Q: Will cars arrive to 2nd booth before all cars serviced at 1st booth?**

- ❑ **Yes!** After 7 min, 1st car at 2nd booth and 3 cars still at 1st booth.
- ❑ 1st bit of packet can arrive at 2nd router before packet is fully transmitted at 1st router!
 - ❖ See Ethernet applet at AWL Web site

Nodal delay

$$d_{\text{nodal}} = d_{\text{proc}} + d_{\text{queue}} + d_{\text{trans}} + d_{\text{prop}}$$

- d_{proc} = processing delay
 - ❖ typically a few microseconds or less
- d_{queue} = queuing delay
 - ❖ depends on congestion
- d_{trans} = transmission delay
 - ❖ $= L/R$, significant for low-speed links
- d_{prop} = propagation delay
 - ❖ a few microseconds to hundreds of msecs

Queueing delay (revisited)

- ❑ R =link bandwidth (bps)
- ❑ L =packet length (bits)
- ❑ a =average packet arrival rate

traffic intensity = La/R

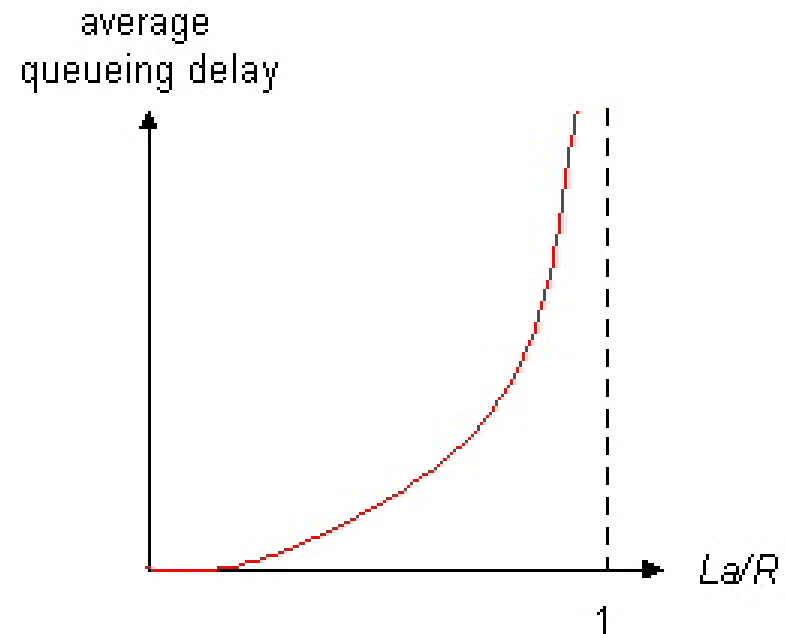

- ❑ $La/R \sim 0$: average queueing delay small
- ❑ $La/R \rightarrow 1$: delays become large
- ❑ $La/R > 1$: more “work” arriving than can be serviced, average delay infinite!

“Real” Internet delays and routes

- ❑ What do “real” Internet delay & loss look like?
- ❑ **Traceroute program**: provides delay measurement from source to router along end-end Internet path towards destination. For all i :
 - ❖ sends three packets that will reach router i on path towards destination
 - ❖ router i will return packets to sender
 - ❖ sender times interval between transmission and reply.

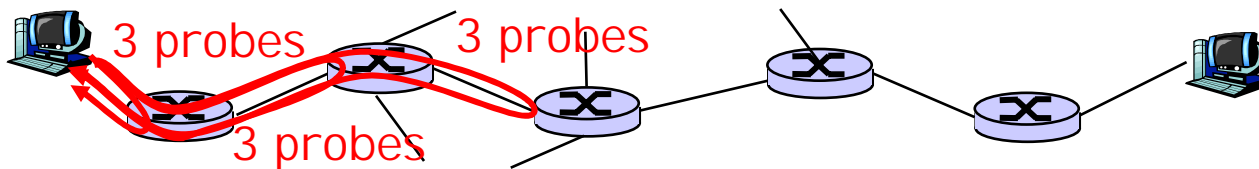

"Real" Internet delays and routes

traceroute: gaia.cs.umass.edu to www.eurecom.fr

Three delay measurements from
gaia.cs.umass.edu to cs-gw.cs.umass.edu



1 cs-gw (128.119.240.254) 1 ms 1 ms 2 ms
2 border1-rt-fa5-1-0.gw.umass.edu (128.119.3.145) 1 ms 1 ms 2 ms
3 cht-vbns.gw.umass.edu (128.119.3.130) 6 ms 5 ms 5 ms
4 jn1-at1-0-0-19.wor.vbns.net (204.147.132.129) 16 ms 11 ms 13 ms
5 jn1-so7-0-0-0.wae.vbns.net (204.147.136.136) 21 ms 18 ms 18 ms
6 abilene-vbns.abilene.ucaid.edu (198.32.11.9) 22 ms 18 ms 22 ms
7 nycm-wash.abilene.ucaid.edu (198.32.8.46) 22 ms 22 ms 22 ms
8 62.40.103.253 (62.40.103.253) 104 ms 109 ms 106 ms
9 de2-1.de1.de.geant.net (62.40.96.129) 109 ms 102 ms 104 ms
10 de.fr1.fr.geant.net (62.40.96.50) 113 ms 121 ms 114 ms
11 renater-gw.fr1.fr.geant.net (62.40.103.54) 112 ms 114 ms 112 ms
12 nio-n2.cssi.renater.fr (193.51.206.13) 111 ms 114 ms 116 ms
13 nice.cssi.renater.fr (195.220.98.102) 123 ms 125 ms 124 ms
14 r3t2-nice.cssi.renater.fr (195.220.98.110) 126 ms 126 ms 124 ms
15 eurecom-valbonne.r3t2.ft.net (193.48.50.54) 135 ms 128 ms 133 ms
16 194.214.211.25 (194.214.211.25) 126 ms 128 ms 126 ms
17 * * *
18 * * *
19 fantasia.eurecom.fr (193.55.113.142) 132 ms 128 ms 136 ms

trans-oceanic link

* means no response (probe lost, router not replying)

Packet loss

- ❑ queue (aka buffer) preceding link in buffer has finite capacity
- ❑ packet arriving to full queue dropped (aka lost)
- ❑ lost packet may be retransmitted by previous node, by source end system, or not at all

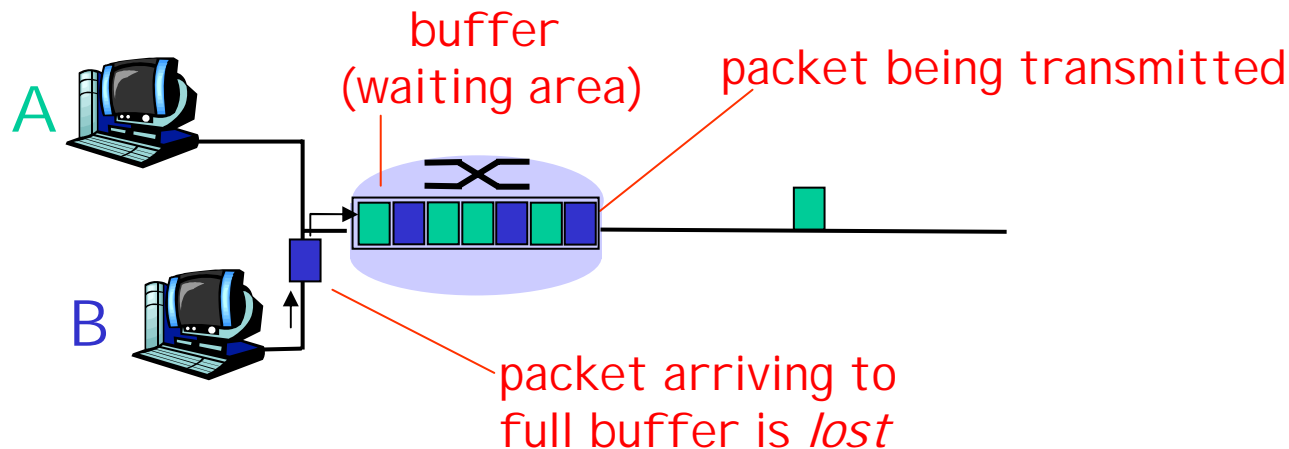

Throughput

- ❑ *throughput*: rate (bits/time unit) at which bits transferred between sender/receiver
 - ❖ *instantaneous*: rate at given point in time
 - ❖ *average*: rate over longer period of time

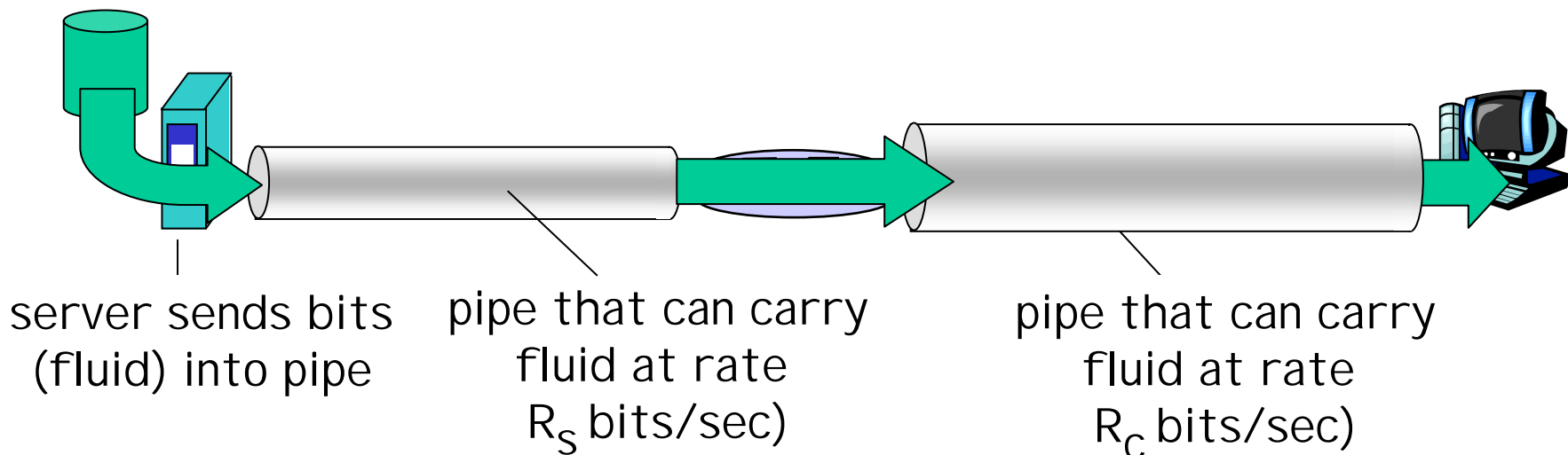

Throughput (more)

- $R_s < R_c$ What is average end-end throughput?

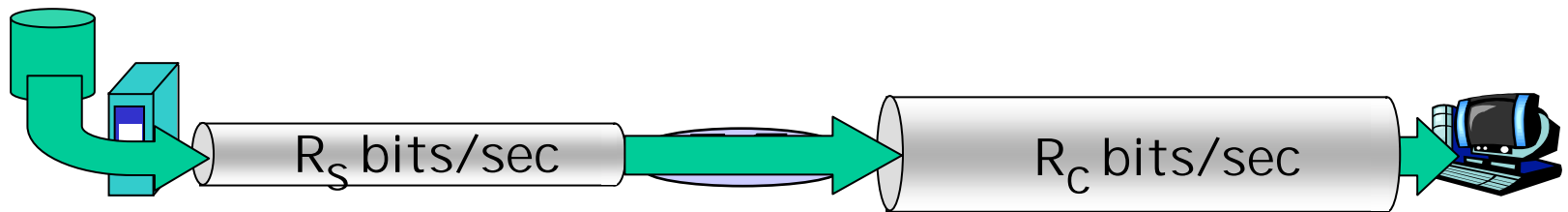

- $R_s > R_c$ What is average end-end throughput?

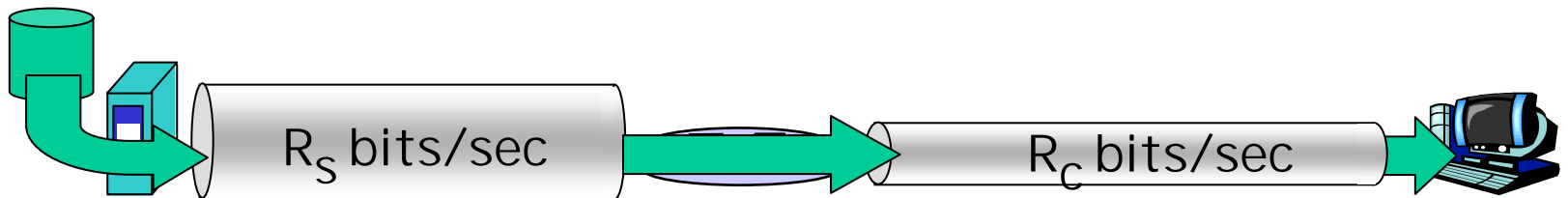

bottleneck link

link on end-end path that constrains end-end throughput

Throughput: Internet scenario

- per-connection end-end throughput: $\min(R_C, R_S, R/10)$
- in practice: R_C or R_S is often bottleneck

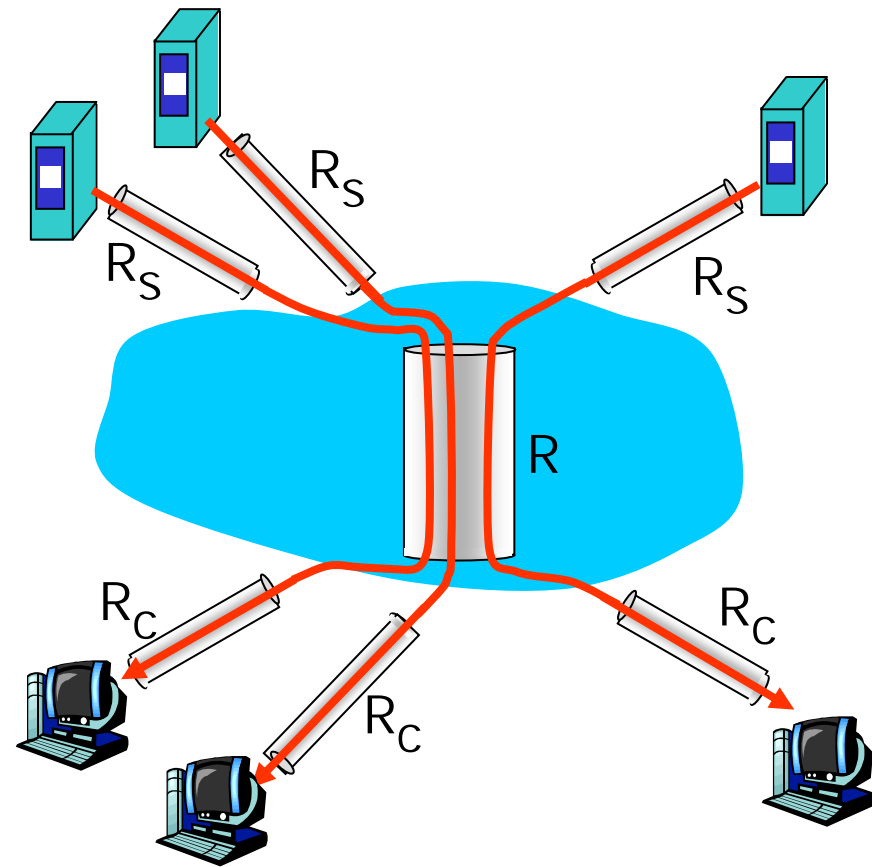

10 connections (fairly) share backbone bottleneck link R bits/sec

Chapter 1: roadmap

1.1 What *is* the Internet?

1.2 Network edge

- end systems, access networks, links

1.3 Network core

- circuit switching, packet switching, network structure

1.4 Delay, loss and throughput in packet-switched networks

1.5 Protocol layers, service models

1.6 Networks under attack: security

1.7 History

Protocol “Layers”

Networks are complex!

- many “pieces”:
 - ❖ hosts
 - ❖ routers
 - ❖ links of various media
 - ❖ applications
 - ❖ protocols
 - ❖ hardware, software

Question:

Is there any hope of *organizing* structure of network?

Or at least our discussion of networks?

Organization of air travel

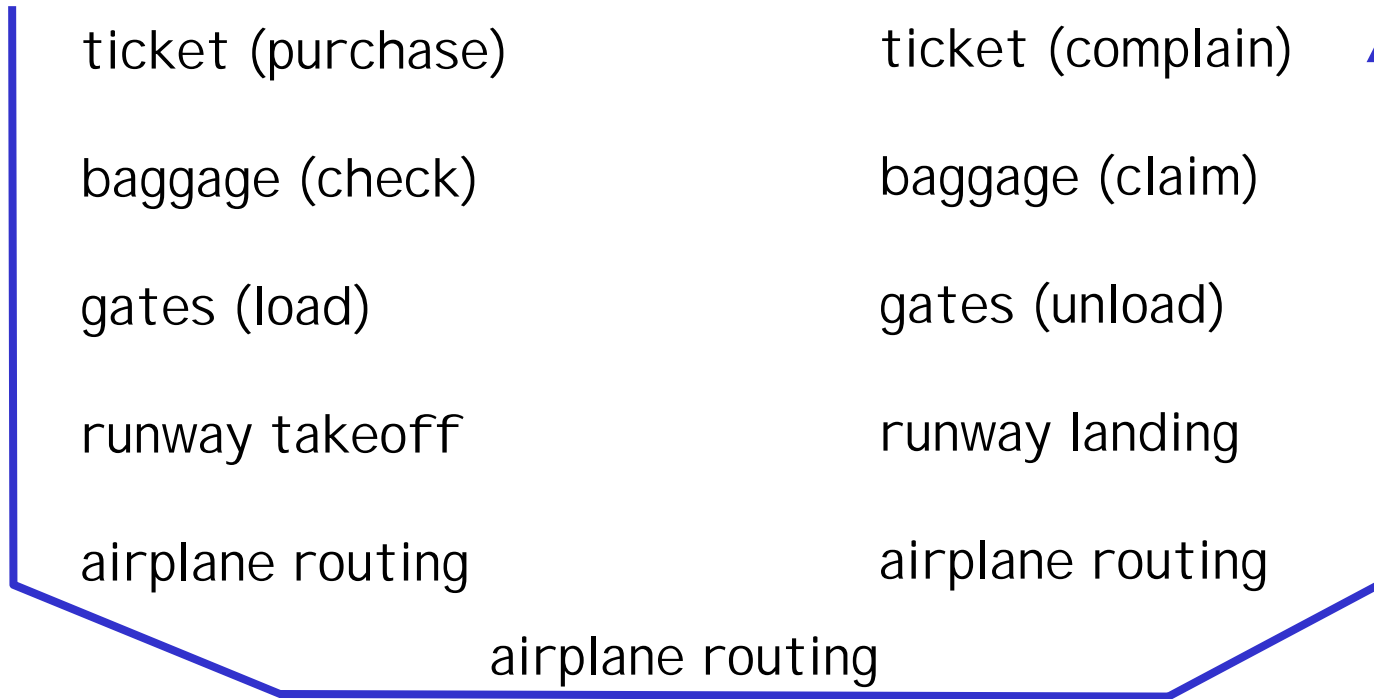

□ a series of steps

Layering of airline functionality

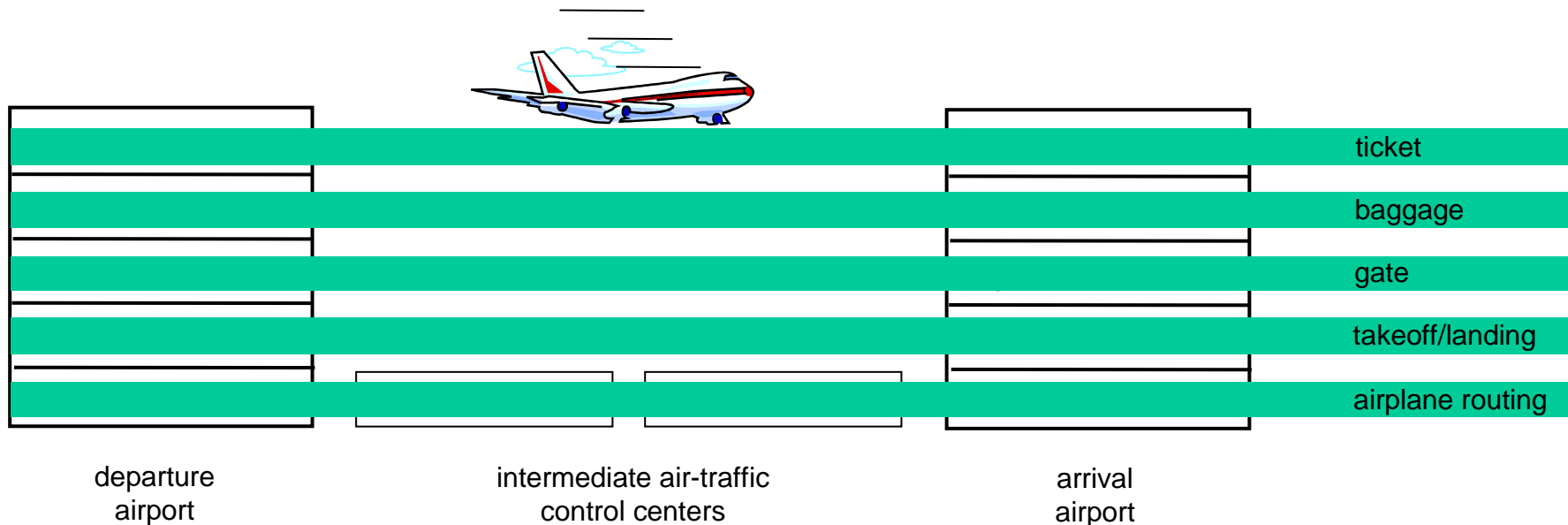

Layers: each layer implements a service

- ❖ via its own internal-layer actions
- ❖ relying on services provided by layer below

Why layering?

Dealing with complex systems:

- ❑ explicit structure allows identification, relationship of complex system's pieces
 - ❖ layered **reference model** for discussion
- ❑ modularization eases maintenance, updating of system
 - ❖ change of implementation of layer's service transparent to rest of system
 - ❖ e.g., change in gate procedure doesn't affect rest of system
- ❑ layering considered harmful?

Internet protocol stack

- ❑ **application:** supporting network applications
 - ❖ FTP, SMTP, HTTP
- ❑ **transport:** process-process data transfer
 - ❖ TCP, UDP
- ❑ **network:** routing of datagrams from source to destination
 - ❖ IP, routing protocols
- ❑ **link:** data transfer between neighboring network elements
 - ❖ PPP, Ethernet
- ❑ **physical:** bits “on the wire”

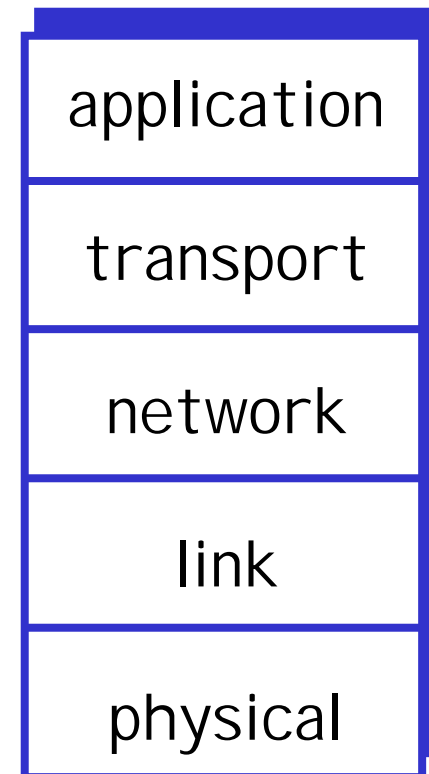

ISO/OSI reference model

- ❑ **presentation**: allow applications to interpret meaning of data, e.g., encryption, compression, machine-specific conventions
- ❑ **session**: synchronization, checkpointing, recovery of data exchange
- ❑ Internet stack “missing” these layers!
 - ❖ these services, *if needed*, must be implemented in application
 - ❖ needed?

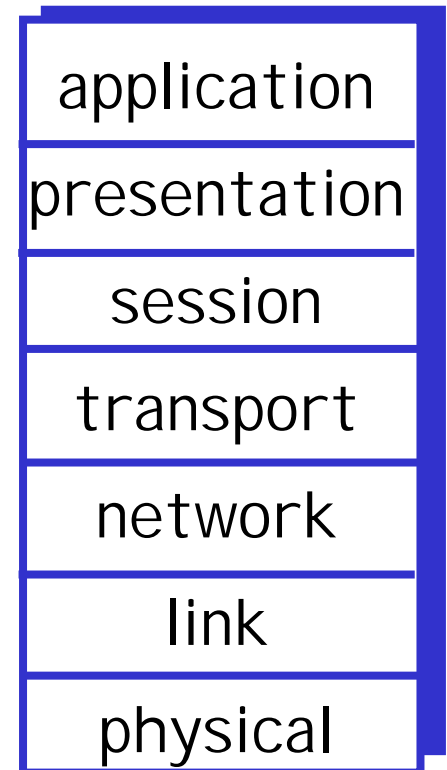

Encapsulation

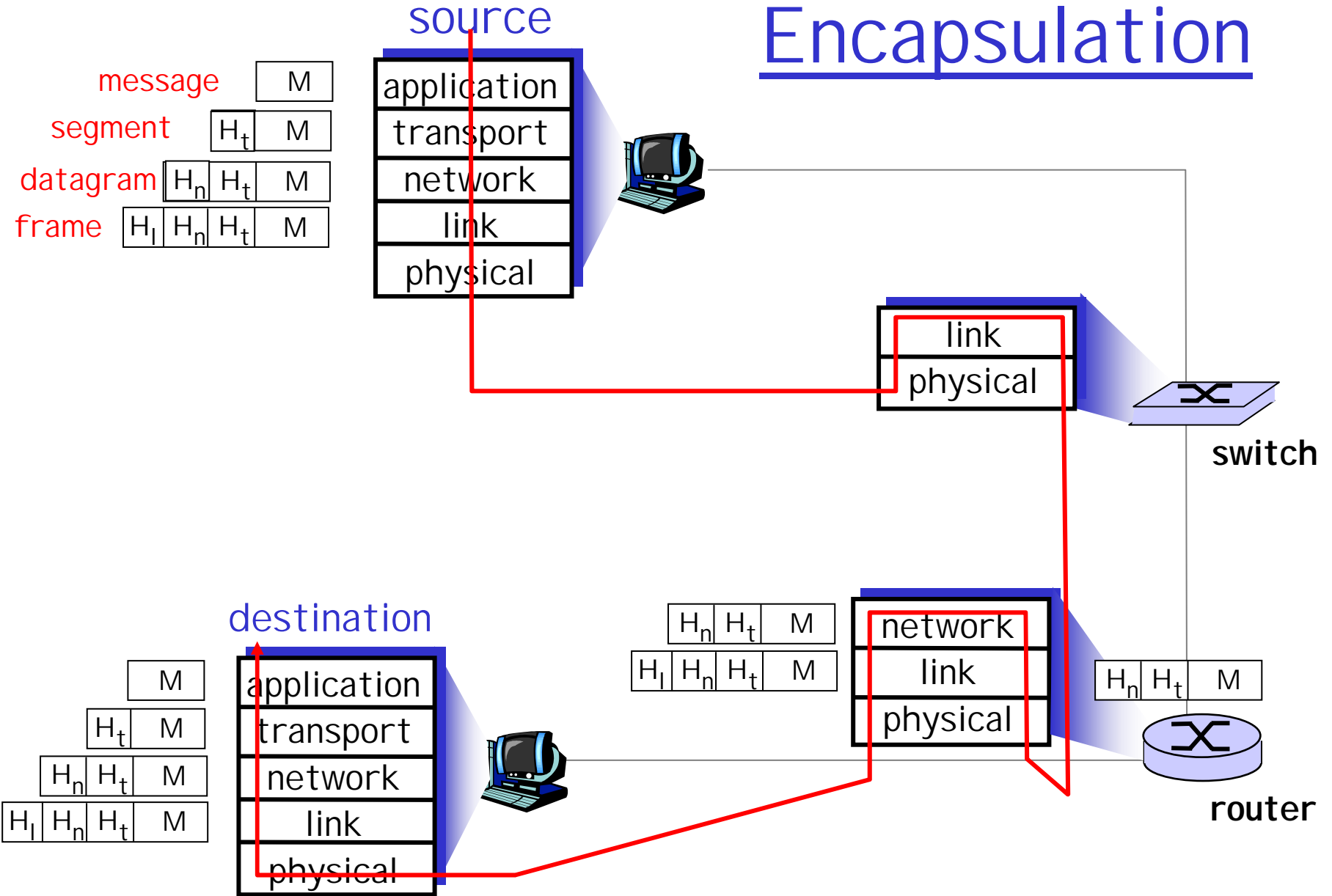

Chapter 1: roadmap

1.1 What *is* the Internet?

1.2 Network edge

- end systems, access networks, links

1.3 Network core

- circuit switching, packet switching, network structure

1.4 Delay, loss and throughput in packet-switched networks

1.5 Protocol layers, service models

1.6 Networks under attack: security

1.7 History

Network Security

- ❑ The field of network security is about:
 - ❖ how bad guys can attack computer networks
 - ❖ how we can defend networks against attacks
 - ❖ how to design architectures that are immune to attacks
- ❑ Internet not originally designed with (much) security in mind
 - ❖ *original vision*: "a group of mutually trusting users attached to a transparent network" 😊
 - ❖ Internet protocol designers playing "catch-up"
 - ❖ Security considerations in all layers!

Bad guys can put malware into hosts via Internet

- ❑ Malware can get in host from a **virus**, **worm**, or **trojan horse**.
- ❑ **Spyware malware** can record keystrokes, web sites visited, upload info to collection site.
- ❑ Infected host can be enrolled in a **botnet**, used for spam and DDoS attacks.
- ❑ Malware is often **self-replicating**: from an infected host, seeks entry into other hosts

Bad guys can put malware into hosts via Internet

❑ Trojan horse

- ❖ Hidden part of some otherwise useful software
- ❖ Today often on a Web page (Active-X, plugin)

❑ Virus

- ❖ infection by receiving object (e.g., e-mail attachment), actively executing
- ❖ self-replicating: propagate itself to other hosts, users

❑ Worm:

- ❖ infection by passively receiving object that gets itself executed
- ❖ self-replicating: propagates to other hosts, users

Sapphire Worm: aggregate scans/sec in first 5 minutes of outbreak (CAIDA, UWisc data)

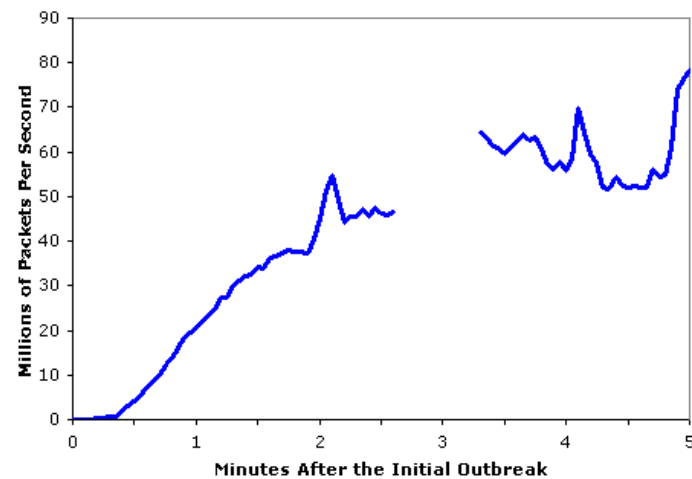

Bad guys can attack servers and network infrastructure

- ❑ Denial of service (DoS): attackers make resources (server, bandwidth) unavailable to legitimate traffic by overwhelming resource with bogus traffic

1. select target
2. break into hosts around the network (see botnet)
3. send packets toward target from compromised hosts

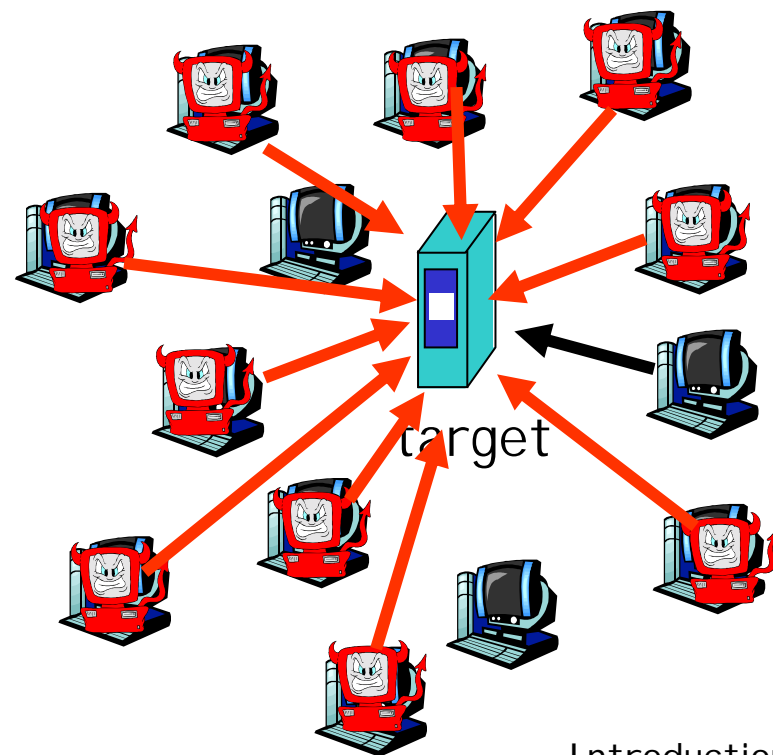

The bad guys can sniff packets

Packet sniffing:

- ❖ broadcast media (shared Ethernet, wireless)
- ❖ promiscuous network interface reads/records all packets (e.g., including passwords!) passing by

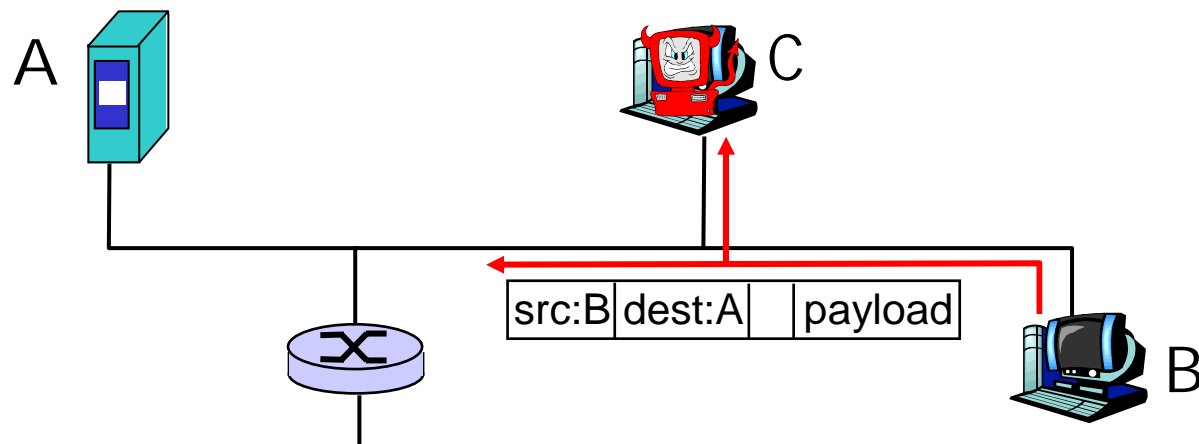

- ❖ Wireshark software used for end-of-chapter labs is a (free) packet-sniffer

The bad guys can use false source addresses

- ❑ *IP spoofing*: send packet with false source address

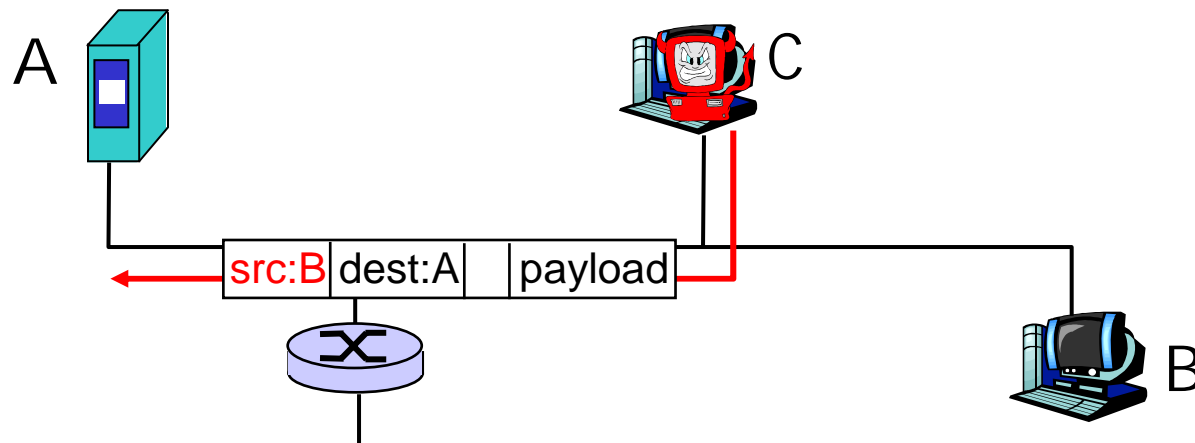

The bad guys can record and playback

- ❑ *record-and-playback*: sniff sensitive info (e.g., password), and use later
 - ❖ password holder *is* that user from system point of view

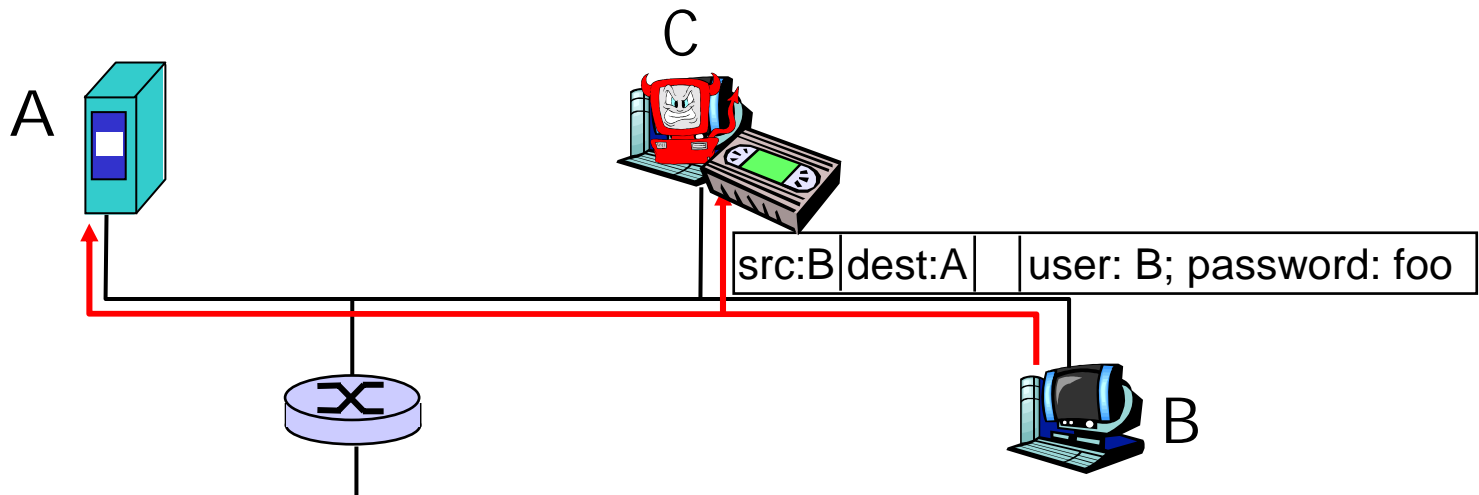

Network Security

- ❑ more throughout this course
- ❑ chapter 8: focus on security
- ❑ cryptographic techniques: obvious uses and not so obvious uses

Chapter 1: roadmap

1.1 What *is* the Internet?

1.2 Network edge

- end systems, access networks, links

1.3 Network core

- circuit switching, packet switching, network structure

1.4 Delay, loss and throughput in packet-switched networks

1.5 Protocol layers, service models

1.6 Networks under attack: security

1.7 History

Internet History

1961-1972: Early packet-switching principles

- 1961: Kleinrock - queueing theory shows effectiveness of packet-switching
- 1964: Baran - packet-switching in military nets
- 1967: ARPAnet conceived by Advanced Research Projects Agency
- 1969: first ARPAnet node operational
- 1972:
 - ❖ ARPAnet public demonstration
 - ❖ NCP (Network Control Protocol) first host-host protocol
 - ❖ first e-mail program
 - ❖ ARPAnet has 15 nodes

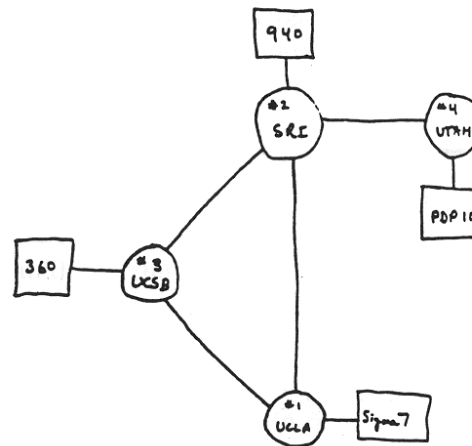

THE ARPA NETWORK

Internet History

1972-1980: Internetworking, new and proprietary nets

- ❑ 1970: ALOHAnet satellite network in Hawaii
- ❑ 1974: Cerf and Kahn - architecture for interconnecting networks
- ❑ 1976: Ethernet at Xerox PARC
- ❑ late 70's: proprietary architectures: DECnet, SNA, XNA
- ❑ late 70's: switching fixed length packets (ATM precursor)
- ❑ 1979: ARPAnet has 200 nodes

Cerf and Kahn's internetworking principles:

- ❖ minimalism, autonomy - no internal changes required to interconnect networks
- ❖ best effort service model
- ❖ stateless routers
- ❖ decentralized control

define today's Internet architecture

Internet History

1980-1990: new protocols, a proliferation of networks

- ❑ 1983: deployment of TCP/IP
- ❑ 1982: smtp e-mail protocol defined
- ❑ 1983: DNS defined for name-to-IP-address translation
- ❑ 1985: ftp protocol defined
- ❑ 1988: TCP congestion control
- ❑ new national networks: Csnet, BITnet, NSFnet, Minitel
- ❑ 100,000 hosts connected to confederation of networks

Internet History

1990, 2000's: commercialization, the Web, new apps

- ❑ Early 1990's: ARPAnet decommissioned
- ❑ 1991: NSF lifts restrictions on commercial use of NSFnet (decommissioned, 1995)
- ❑ early 1990s: Web
 - ❖ hypertext [Bush 1945, Nelson 1960's]
 - ❖ HTML, HTTP: Berners-Lee
 - ❖ 1994: Mosaic, later Netscape
 - ❖ late 1990's: commercialization of the Web

Late 1990's – 2000's:

- ❑ more killer apps: instant messaging, P2P file sharing
- ❑ network security to forefront
- ❑ est. 50 million host, 100 million+ users
- ❑ backbone links running at Gbps

Internet History

2007:

- ❑ ~500 million hosts
- ❑ Voice, Video over IP
- ❑ P2P applications: BitTorrent (file sharing) Skype (VoIP), PPLive (video)
- ❑ more applications: YouTube, gaming
- ❑ wireless, mobility

Introduction: Summary

Covered a "ton" of material!

- ❑ Internet overview
- ❑ what's a protocol?
- ❑ network edge, core, access network
 - ❖ packet-switching versus circuit-switching
 - ❖ Internet structure
- ❑ performance: loss, delay, throughput
- ❑ layering, service models
- ❑ security
- ❑ history

You now have:

- ❑ context, overview, "feel" of networking
- ❑ more depth, detail *to follow!*